



TECHNICAL GUIDE

Echelon R-410A SPLIT-SYSTEM AIR CONDITIONERS 18 SEER MODELS: AC8B024 THRU 060 (2 THRU 5 NOMINAL TONS)



Due to continuous product improvement, specifications are subject to change without notice.

Visit us on the web at www.york.com for the most up-to-date technical information.

Additional rating information can be found at www.ahridirectory.org

DESCRIPTION

The AC8B Series condensing unit is the outdoor part of a versatile air conditioning system. It is designed to be custom matched with one of our complete line of evaporator sections, each designed to serve a specific function. Matching air handlers are available for upflow, downflow, and horizontal left or right application to provide a complete system. Electric heaters are available if required. Add-on coils are available for use with upflow, downflow, or horizontal furnaces. Field installed accessories are available as needed.

WARRANTY

5-year limited parts warranty.

10-year limited compressor warranty.

Premium System Warranty - Limited lifetime compressor and 10-year parts when matched with an approved Coleman Echelon furnace or UPG air handler and coil.

FEATURES

- **Superior Coil Protection** – A PVC coated steel coil guard completely protects coil from debris and other large damaging material while a polymer mesh further protects the coil against smaller particles.
- **Isolated Compressor Compartment** – A molded composite bulkhead isolates the compressor from the rest of the unit reducing sound and vibration.
- **Protected Compressors** – Each compressor is protected against abnormal pressures by an internal pressure relief valve and factory installed high and low pressure controls. Additional protection against moisture and debris is provided by factory installed liquid line filter driers.
- **Environmentally Friendly Refrigerant** – Next generation refrigerant R-410A delivers environmentally friendly performance with zero ozone depletion.
- **Durable Finish** – Automotive quality finish provides the ultimate protection from harmful U.V. rays and rust creep ensuring long-lasting high quality appearance. A powder-paint topcoat is applied over a baked-on primer, using a galvanized, zinc coated steel base material. The result is a finish that has been proven in testing to provide 33% greater durability than conventional powder-coat finishes.
- **Lower Installed Cost** – Designed to provide enhanced installability by featuring a slide-down control compartment and angled service valves to reduce overall installation time and cost.
- **Low Operating Sound Levels** – A fan design boasting technology adapted from aeronautic and defense engineering provides for whisper quiet operation by allowing airflow to flow smoothly and efficiently across the fan tips.
- **Filter-Drier** – A factory installed, solid core liquid line filter-drier filters harmful debris and moisture from the system.
- **Easy Service Access** – A full end, full service, access panel with handle makes for easy entry to internal components.
- **Composite Base** - Strong and durable composite base pan resists rust and corrosion while it helps reduce vibrations and noise.
- **Whisper drive system** - Features combination of swept-wing fan, composite base pan, isolated compressor compartment and two-stage compressor to reduce overall sound to a mere whisper.
- **Low RPM fan motor** - Helps to reduce airflow noise.
- **Agency Listed** - U.L. and C.U.L. listed - approved for outdoor application. The unit is certified in accordance with the Unitary Small Equipment certification program, which is based on ARI Standard 210/240.

Physical and Electrical Data

MODEL		AC8B024F1	AC8B036F1	AC8B048F1	AC8B060F1
Unit Supply Voltage		208-230V, 1 ϕ , 60Hz			
Normal Voltage Range ¹		187 to 252			
Minimum Circuit Ampacity		15.6	23.6	29.2	34.8
Max. Overcurrent Device Amps ²		25	40	50	60
Min. Overcurrent Device Amps ³		20	25	30	35
Multi-stage Compressor		Yes	Yes	Yes	Yes
Compressor Type		Scroll	Scroll	Scroll	Scroll
Compressor Amps	Rated Load	10.3	16.7	21.2	25.6
	Locked Rotor	52	82	96	118
Crankcase Heater		No	No	No	No
Fan Motor Amps	Rated Load	2.8	2.8	2.8	2.8
Fan Diameter Inches		24	24	24	24
Fan Motor	Rated HP	1/3	1/3	1/3	1/3
	Nominal RPM	685	685	685	685
	Nominal CFM	2900	3200	3100	3150
Coil	Face Area Sq. Ft.	23.58	23.58	23.58	23.58
	Rows Deep	2	2	2	2
	Fins / Inch	16	16	14	14
Liquid Line Set OD (Field Installed)		3/8	3/8	3/8	3/8
Vapor Line Set OD (Field Installed)		3/4	3/4	7/8	7/8
Unit Charge (Lbs. - Oz.) ⁴		15 - 1	13 - 7	12 - 9	13 - 5
Charge Per Foot, Oz.		0.62	0.62	0.67	0.67
Operating Weight Lbs.		305	305	310	330

1 Rated in accordance with ARI Standard 110, utilization range "A".

2 Dual element fuses or HACR circuit breaker. Maximum allowable overcurrent protection.

3 Dual element fuses or HACR circuit breaker. Minimum recommended overcurrent protection.

4 The Unit Charge is correct for the outdoor unit, matched indoor coil and 15 feet of refrigerant tubing. For tubing lengths other than 15 feet, add or subtract the amount of refrigerant, using the difference in length multiplied by the per foot value.

All dimensions are in inches. They are subject to change without notice. Certified dimensions will be provided upon request.

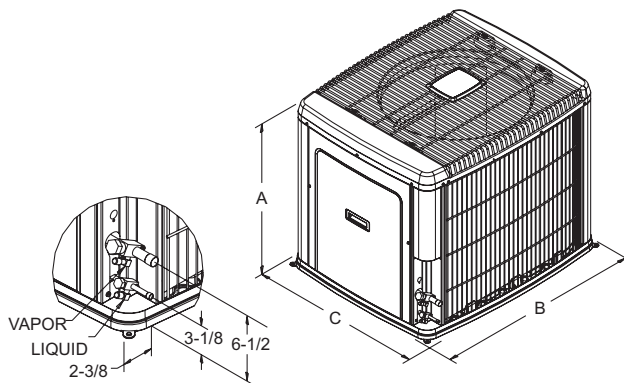

Unit Model	Dimensions (Inches)			Refrigerant Connection Service Valve Size	
	A	B	C	Liquid	Vapor
24	39-1/2	42	34	3/8"	3/4"
36	39-1/2	42	34		
48	39-1/2	42	34		7/8"
60	39-1/2	42	34		

Additional R-410A Charge / TXV Size for Various Matched Systems				
Outdoor Unit	AC8B024F1	AC8B036F1	AC8B048F1	AC8B060F1
Approved System Thermal Expansion Valve ¹	1TVM(902/4F1)	1TVM(904/4H1)	1TVM(905/4J1)	1TVM(906/4K1)
Factory Charge, lbs-oz	16 - 2	15 - 14	13 - 8	14 - 1
Indoor Coil ²	TXV Kit ³ - Additional Charge, Oz			
FC/MC/PC32A	1	–	–	–
FC/MC/PC35B	0	–	–	–
FC/MC/PC35C	0	–	–	–
FC/MC/PC37A	7	24	–	–
FC/MC/PC43B	7	24	–	–
FC/MC/PC43C	7	24	–	–
FC/MC/PC48C	17	7	10	–
FC/MC/PC48D	17	7	10	–
FC/PC60C	–	–	–	0
FC/MC/PC60D	–	–	–	0
FC/MC62D	–	39	15	12
HC36B	0	–	–	–
HC42C	–	24	–	–
HC60D	–	–	1	0
UC48D	17	7	10	–
UC60D	–	–	–	0
AV36C	7	0	–	–
AV/SV48D	–	–	1	–
AV/SV60D	–	–	0	0
F4FV060D	–	–	1	0

FOOTNOTES:

- 1 Systems matched with furnace or air handlers not equipped with blower-off delays may require blower Time Delay Kit 2FD06700224.
- 2 PC coils cannot be used in downflow or horizontal applications. FC coils cannot be used in horizontal applications.
- 3 A TXV kit must be used with these coils to obtain system performance.

Note: If a TXV is factory installed on the coil, it must be replaced with the listed TXV.

PROCEDURES:

1. Unit factory charge listed on the unit nameplate includes refrigerant for the condenser, the smallest evaporator and 15 feet of interconnecting line tubing.
2. Verify the TXV and additional charge required for specific evaporator coil in the system using the above table.
3. Additional charge for the amount of interconnecting line tubing greater than 15 feet at the rate specified on the previous page.
4. Permanently mark the unit nameplate with the total system charge. Total System Charge = Base Charge (as shipped) + adder for evaporator + adder for line set.

COOLING CAPACITY - With Air Handler Coils

UNIT MODEL	AIR HANDLER		COIL MODEL ¹	COOLING					
	MODEL	W		STAGE	RATED CFM	NET MBH	SEER	EER	
1 PH 18 SEER AC WITH MV									
AC8B024F1	MV12B	17	FC/MC/PC35B	1	620	18.2	13.8	17.05	14.50
				2	800	23.6	17.2		13.80
	MV12B	17	FC/MC/PC35C	1	620	18.2	13.8	17.05	14.50
				2	800	23.6	17.2		13.80
	MV12B	17	FC/MC/PC43B	1	620	18.5	14.0	17.20	14.65
				2	800	24.0	17.5		14.00
	MV12B	17	FC/MC/PC43C	1	620	18.5	14.0	17.20	14.65
				2	800	24.0	17.5		14.00
	MV12D	24	FC/MC/PC48D	1	645	18.9	14.3	18.00	15.25
				2	835	24.6	17.9		14.45
AC8B036F1	MV12B	17	FC/MC/PC43B	1	775	25.6	18.0	17.70	14.90
				2	1200	36.0	25.2		13.55
	MV16C	21	FC/MC/PC43C	1	775	25.7	18.1	18.00	15.00
				2	1200	36.2	25.3		14.00
	MV12D	24	FC/MC/PC48D	1	735	25.6	18.0	18.40	15.40
				2	1135	36.0	25.2		13.95
	MV16C	21	FC/MC/PC48C	1	775	25.9	18.2	18.40	15.40
				2	1200	36.4	25.4		14.15
	MV12D	24	FC/MC62D	1	735	25.7	18.1	18.50	15.40
				2	1135	36.6	25.6		14.25
AC8B048F1	MV16C	21	FC/MC/PC48C	1	1000	34.0	25.1	17.30	14.20
				2	1600	46.0	35.1		12.45
	MV16C	21	FC/MC/PC48D	1	1000	34.0	25.1	17.30	14.20
				2	1600	46.0	35.1		12.45
	MV20D	24	FC/MC/PC48D	1	1020	34.0	25.1	17.00	14.00
				2	1600	46.0	35.1		12.35
	MV20D	24	FC/MC62D	1	1020	34.1	25.2	17.00	14.05
				2	1600	46.5	35.5		12.50
AC8B060F1	MV20D	24	FC/MC/PC60D	1	1030	40.2	27.3	15.30	12.55
				2	1800	55.5	40.5		11.55
	MV20D	24	FC/MC62D	1	1030	42.1	28.6	16.00	13.20
				2	1800	58.0	42.3		12.00
1 PH 18 SEER AC WITH AV/SV									
AC8B024F1	AV36C	21	N / A	1	600	18.4	13.9	17.60	14.95
				2	765	23.8	17.3		14.10
AC8B036F1	AV36C	21	N / A	1	830	25.7	18.1	18.00	15.25
				2	1270	35.6	24.9		13.45
AC8B048F1	AV/SV48D	24	N / A	1	1135	33.1	24.4	16.60	13.60
				2	1610	44.5	34.0		12.10
	AV/SV60D	24	N / A	1	1085	33.0	24.4	16.50	13.60
				2	1655	44.5	34.0		12.10
AC8B060F1	AV/SV60D	24	N / A	1	1145	41.5	28.2	15.70	13.00
				2	1765	55.5	40.5		11.65
1 PH 18 SEER AC WITH F*F*									
AC8B048F1	F4FV060	24	N / A	1	1200	33.6	24.8	16.85	13.75
				2	1600	44.5	34.0		12.15
AC8B060F1	F4FV060	24	N / A	1	1200	41.8	28.4	15.55	12.80
				2	1780	55.5	40.5		11.60

Rated in accordance with DOE test procedures (Federal Register 12-27-79 and 3-18-88) and ARI Standards 210.

Cooling MBH based on 80°F entering air temperature, 50% RH, and rated air flow.

EER (Energy Efficiency Ratio) is the total cooling output in BTU's at 95°F outdoor ambient divided by the total electric power in watt-hours at those conditions.

SEER (Seasonal Energy Efficiency Ratio) is the total cooling output in BTU's during a normal annual usage period for cooling divided by the total electric power input in watt-hours during the same period.

1 MC coils available with a factory installed horizontal drain pan. See price pages for specific model number.

COOLING CAPACITY - AC8B024F1 With Variable Speed Furnaces

VARIABLE SPEED FURNACE MODEL	COIL MODEL ¹	W	COOLING					
			STAGE	RATED CFM	NET MBH		SEER	EER
					TOTAL	SENSIBLE		
1 PH 18 SEER AC WITH VARIABLE SPEED FURNACES²								
(F,L)C8V*A12	FC/MC/PC32A	14	1	470	17.2	13.0	16.70	14.15
			2	750	23.2	16.9		13.55
(F,L)C9V*A12	FC/MC/PC32A	14	1	625	18.1	13.7	16.60	14.25
			2	800	23.2	16.9		13.05
(F,L)C9(C,V)*B12	FC/MC/PC35B	17	1	560	17.9	13.6	17.05	14.55
			2	820	23.4	17.0		13.45
(F,L)C8V*A12	FC/MC/PC37A	14	1	470	17.4	13.2	17.00	14.35
			2	750	23.6	17.2		13.75
(F,L)C9V*A12	FC/MC/PC37A	14	1	625	18.6	14.1	17.00	14.60
			2	800	23.6	17.2		13.30
(F,L)C9(C,V)*B12	FC/MC/PC43B	14	1	560	18.1	13.7	17.35	14.70
			2	820	24.0	17.5		13.70
(F,L)C9(C,V)*B12	HC36B	17	1	560	17.9	13.6	17.10	14.55
			2	820	23.4	17.0		13.55
C*(8,L)C*A12	FC/MC/PC30A	14	1	590	17.7	13.1	16.75	14.25
			2	805	23.0	16.3		13.50
C*(8,L)C*B12	FC/MC/PC30B	17	1	565	17.8	13.1	17.00	14.50
			2	815	23.2	16.3		13.50
C*9C*B12	FC/MC/PC30B	17	1	565	17.7	13.1	16.75	14.25
			2	790	23.0	16.3		13.50
C*(8,L)C*A12	FC/MC/PC32A	14	1	550	17.5	12.7	16.50	14.00
			2	775	23.0	16.1		13.25
C*(8,L)C*B12	FC/MC/PC35B	17	1	515	17.4	12.4	16.50	14.00
			2	760	23.0	16.1		13.50
C*9C*B12	FC/MC/PC35B	17	1	550	17.5	12.7	16.50	14.25
			2	815	23.2	16.5		13.25
C*(8,L)C*A12	FC/MC/PC36A	14	1	595	17.8	13.3	17.00	14.25
			2	805	23.0	16.4		13.50
C*(8,L)C*B12	FC/MC/PC36B	17	1	525	17.5	12.6	16.75	14.25
			2	765	23.0	16.2		13.75
C*9C*B12	FC/MC/PC36B	17	1	590	17.9	13.2	16.75	14.25
			2	815	23.2	16.6		13.50
C*(8,L)C*A12	FC/MC/PC37A	14	1	585	18.0	13.3	16.75	14.25
			2	805	23.6	16.7		13.50
C*(8,L)C*B12	FC/MC/PC43B	17	1	515	17.5	12.6	16.75	14.25
			2	760	23.4	16.3		13.75
C*9C*B12	FC/MC/PC43B	17	1	550	17.8	12.9	17.00	14.25
			2	800	23.6	16.7		13.75
C*(8,L)C*A12	HC30	14	1	550	17.4	12.6	16.25	13.75
			2	775	22.8	15.9		13.25
C*(8,L)C*A12	HD36	14	1	595	17.5	12.6	16.50	14.00
			2	805	23.0	15.7		13.25
C*(8,L)C*B12	HD36	17	1	515	17.0	11.9	16.00	13.75
			2	760	22.6	15.5		13.25
C*9C*B12	HD36	17	1	590	17.5	12.6	16.50	14.00
			2	815	23.0	15.7		13.50
C*(8,L)C*A12	UC30A	14	1	590	17.7	13.2	16.75	14.25
			2	805	23.2	16.3		13.50
C*(8,L)C*B12	UC30B	17	1	565	17.8	13.3	17.25	14.50
			2	815	23.2	16.3		13.75
C*9C*B12	UC30B	17	1	565	17.8	13.2	17.00	14.25
			2	790	23.2	16.3		13.50
C*(8,L)C*A12	UC36A	14	1	595	17.0	12.8	16.00	13.75
			2	805	22.4	15.7		13.00

For Notes See Page 6.

COOLING CAPACITY - AC8B024F1 With Variable Speed Furnaces (Continued)

VARIABLE SPEED FURNACE MODEL	COIL MODEL ¹	W	COOLING					
			STAGE	RATED CFM	NET MBH		SEER	EER
					TOTAL	SENSIBLE		
1 PH 18 SEER AC WITH VARIABLE SPEED FURNACES²								
C*(8,L)C*B12	UC36B	17	1	525	16.6	11.9	16.00	13.50
			2	765	22.2	15.5		13.25
C*9C*B12	UC36B	17	1	590	17.0	12.8	16.00	13.75
			2	815	22.4	15.7		13.00
G*9V*A12	FC/MC/PC30A	14	1	625	17.8	13.4	16.50	14.00
			2	800	23.0	16.2		13.25
G*9V*A12	FC/MC/PC32A	14	1	625	17.8	13.4	16.25	14.00
			2	800	23.0	16.3		13.00
G*9V*A12	FC/MC/PC36A	14	1	625	17.9	13.5	16.50	14.00
			2	800	22.8	16.3		13.00
G*9V*A12	FC/MC/PC37A	14	1	535	17.6	12.7	16.25	14.00
			2	800	23.4	16.6		13.25
G*9V*A12	HC30	14	1	625	17.7	13.3	16.25	13.75
			2	800	22.8	16.0		13.00
G*9V*A12	HD36	14	1	625	17.6	12.7	16.00	13.75
			2	800	22.8	15.5		13.00
G*9V*A12	UC30A	14	1	625	18.0	13.4	16.50	14.00
			2	800	23.2	16.2		13.25
G*9V*A12	UC36A	14	1	625	17.1	12.8	15.75	13.25
			2	800	22.2	15.6		12.75
G*9V*B12	FC/MC/PC30B	17	1	565	17.7	13.1	16.75	14.25
			2	790	23.0	16.3		13.50
G*9V*B12	FC/MC/PC35B	17	1	550	17.5	12.7	16.50	14.25
			2	815	23.2	16.5		13.25
G*9V*B12	FC/MC/PC36B	17	1	590	17.9	13.2	16.75	14.25
			2	815	23.2	16.6		13.50
G*9V*B12	FC/MC/PC43B	17	1	550	17.8	12.9	17.00	14.25
			2	800	23.6	16.7		13.75
G*9V*B12	HD36	17	1	590	17.5	12.6	16.50	14.00
			2	815	23.0	15.7		13.50
G*9V*B12	UC30B	17	1	565	17.8	13.2	17.00	14.25
			2	790	23.2	16.3		13.50
G*9V*B12	UC36B	17	1	590	17.0	12.8	16.00	13.75
			2	818	22.4	15.7		13.00

1 MC coils available with a factory installed horizontal drain pan.

2 Variable speed furnaces have B.O.D (Blower on Delay) standard.

COOLING CAPACITY - AC8B036F1With Variable Speed Furnaces

VARIABLE SPEED FURNACE MODEL	COIL MODEL ¹	W	COOLING					
			STAGE	RATED CFM	NET MBH		SEER	EER
					TOTAL	SENSIBLE		
1 PH 18 SEER AC WITH VARIABLE SPEED FURNACES²								
(F,L)C8V*A12	FC/MC/PC37A	14	1	750	25.4	17.9	17.50	14.80
			2	1185	35.8	25.0		13.25
(F,L)C9V*A12	FC/MC/PC37A	14	1	780	25.6	18.0	17.50	14.75
			2	1200	35.6	24.9		13.00
(F,L)C8V*B16	FC/MC/PC43B	17	1	750	25.4	17.9	17.80	14.90
			2	1200	36.0	25.2		13.70
(F,L)C8V*C16	FC/MC/PC43C	21	1	640	24.6	17.3	17.70	14.80
			2	1200	36.2	25.3		13.80
(F,L)C8V*C20	FC/MC/PC43C	21	1	780	25.7	18.1	17.90	15.10
			2	1200	36.0	25.2		13.50
(F,L)C9(C,V)*B12	FC/MC/PC43B	17	1	770	25.6	18.0	17.60	14.85
			2	1185	35.6	24.9		13.25
(F,L)C9(C,V)*C16	FC/MC/PC43C	21	1	770	25.7	18.1	18.00	15.30
			2	1175	35.8	25.0		13.60
(F,L)C9(C,V)*C20	FC/MC/PC43C	21	1	790	25.8	18.1	17.90	15.05
			2	1195	36.0	25.2		13.65
(F,L)C8V*C16	FC/MC/PC48C	21	1	640	24.7	17.4	18.20	15.15
			2	1200	36.4	25.4		14.00
(F,L)C8V*C16	UC48D	21	1	640	24.7	17.4	18.20	15.15
			2	1200	36.4	25.4		14.00
(F,L)C8V*C20	FC/MC/PC48C	21	1	780	25.9	18.2	18.35	15.45
			2	1200	36.2	25.3		13.55
(F,L)C9(C,V)*C16	FC/MC/PC48C	21	1	770	25.9	18.2	18.40	15.60
			2	1175	36.2	25.3		13.80
(F,L)C9(C,V)*C16	UC48D	21	1	770	25.9	18.2	18.40	15.60
			2	1175	36.2	25.3		13.80
(F,L)C9(C,V)*C20	FC/MC/PC48C	21	1	790	25.9	18.2	18.20	15.25
			2	1195	36.2	25.3		13.75
(F,L)C9(C,V)*C20	UC48D	21	1	790	25.9	18.2	18.20	15.25
			2	1195	36.2	25.3		13.75
(F,L)C9(C,V)*D20	FC/MC/PC48D	24	1	775	25.9	18.2	18.30	15.40
			2	1220	36.4	25.4		13.90
(F,L)C9(C,V)*D20	UC48D	24	1	775	25.9	18.2	18.30	15.40
			2	1220	36.4	25.4		13.90
(F,L)C8V*C20	FC/MC62D	21	1	780	26.0	18.3	18.35	15.40
			2	1200	36.6	25.6		13.70
(F,L)C9(C,V)*C20	FC/MC62D	21	1	790	26.0	18.3	18.20	15.25
			2	1195	36.6	25.6		13.90
(F,L)C9(C,V)*D20	FC/MC62D	24	1	775	26.0	18.3	18.25	15.30
			2	1220	36.8	25.7		14.05
(F,L)C8V*C16	HC42C	21	1	640	24.6	17.3	17.80	14.85
			2	1200	36.2	25.3		13.85
(F,L)C8V*C20	HC42C	21	1	780	25.7	18.1	18.05	15.20
			2	1200	36.0	25.2		13.50
(F,L)C9(C,V)*C16	HC42C	21	1	770	25.6	18.0	18.25	15.25
			2	1175	36.0	25.2		13.75
(F,L)C9(C,V)*C20	HC42C	21	1	790	25.8	18.1	17.90	15.05
			2	1195	36.0	25.2		13.65
C*(8,L)C*B12	FC/MC/PC35B	17	1	745	24.6	16.7	17.00	14.25
			2	1220	35.0	24.3		12.50
C*(8,L)C*C16	FC/MC/PC35C	21	1	815	25.0	17.5	17.25	14.25
			2	1235	35.4	24.7		13.25
C*(8,L)C*C20	FC/MC/PC35C	21	1	960	25.8	19.2	17.25	14.25
			2	1170	35.2	24.3		13.25
C*9C*B12	FC/MC/PC35B	17	1	810	25.0	17.4	16.75	14.00
			2	1190	35.2	24.5		12.75

For Notes See Page 10.

COOLING CAPACITY - AC8B036F1With Variable Speed Furnaces (Continued)

VARIABLE SPEED FURNACE MODEL	COIL MODEL ¹	W	COOLING					
			STAGE	RATED CFM	NET MBH		SEER	EER
					TOTAL	SENSIBLE		
1 PH 18 SEER AC WITH VARIABLE SPEED FURNACES²								
C*9C*C16	FC/MC/PC35C	21	1	790	25.0	17.5	17.25	14.25
			2	1215	35.4	24.7		13.00
C*9C*C20	FC/MC/PC35C	21	1	760	24.6	16.8	17.00	14.25
			2	1330	35.6	25.3		12.75
C*(8,L)C*A12	FC/MC/PC36A	14	1	815	24.8	17.3	16.75	14.00
			2	1190	34.6	23.7		12.50
C*(8,L)C*B12	FC/MC/PC36B	17	1	745	24.6	16.7	17.00	14.25
			2	1220	34.8	24.1		12.75
C*(8,L)C*C16	FC/MC/PC36C	21	1	805	25.0	17.4	17.50	14.50
			2	1235	34.8	24.1		13.00
C*(8,L)C*C20	FC/MC/PC36C	21	1	800	25.0	17.4	17.50	14.50
			2	1240	35.0	24.1		13.25
C*9C*B12	FC/MC/PC36B	17	1	800	25.0	17.3	17.00	14.25
			2	1165	34.8	23.9		12.75
C*9C*C16	FC/MC/PC36C	21	1	915	25.4	18.2	17.25	14.25
			2	1185	34.6	24.1		13.00
C*9C*C20	FC/MC/PC36C	21	1	760	24.6	16.8	17.25	14.25
			2	1320	35.2	25.1		12.75
C*(8,L)C*A12	FC/MC/PC37A	14	1	655	24.2	15.9	16.75	14.00
			2	980	34.2	22.7		13.00
C*(8,L)C*B12	FC/MC/PC42B	17	1	760	24.6	16.9	17.25	14.25
			2	1175	34.8	24.1		13.00
C*(8,L)C*C16	FC/MC/PC42C	21	1	825	25.0	17.6	17.50	14.50
			2	1205	35.4	24.7		13.50
C*(8,L)C*C20	FC/MC/PC42C	21	1	735	24.8	17.0	17.50	14.50
			2	1170	35.0	24.3		13.50
C*9C*B12	FC/MC/PC42B	17	1	800	25.0	17.5	17.00	14.25
			2	1195	34.8	24.3		12.50
C*9C*C16	FC/MC/PC42C	21	1	780	24.6	16.9	17.25	14.25
			2	1205	34.8	24.3		13.25
C*9C*C20	FC/MC/PC42C	21	1	770	24.8	17.0	17.25	14.25
			2	1325	35.4	25.5		13.00
C*(8,L)C*B12	FC/MC/PC43B	17	1	745	24.8	16.9	17.25	14.25
			2	1210	35.4	24.9		12.75
C*(8,L)C*C16	FC/MC/PC43C	21	1	800	25.2	17.6	17.50	14.50
			2	1205	35.8	25.1		13.50
C*(8,L)C*C20	FC/MC/PC43C	21	1	745	24.8	17.0	17.50	14.50
			2	1190	35.8	25.1		13.50
C*9C*B12	FC/MC/PC43B	17	1	815	25.0	17.5	17.00	14.25
			2	1200	35.4	24.9		12.75
C*9C*C16	FC/MC/PC43C	21	1	815	25.2	17.5	17.25	14.25
			2	1240	35.6	25.1		13.00
C*9C*C20	FC/MC/PC43C	21	1	780	24.8	16.9	17.25	14.25
			2	1200	35.8	25.1		13.25
C*(8,L)C*C16	FC/MC/PC48C	21	1	810	25.6	17.9	17.75	14.75
			2	1210	36.4	25.7		13.75
C*(8,L)C*C20	FC/MC/PC48C	21	1	720	24.8	16.9	17.50	14.50
			2	1155	36.2	25.1		13.75
C*9C*C16	FC/MC/PC48C	21	1	780	25.6	17.9	17.75	14.75
			2	1195	36.2	25.5		13.50
C*9C*C20	FC/MC/PC48C	21	1	745	24.8	17.1	17.50	14.50
			2	1330	36.6	26.5		13.25
C*(8,L)C*C16	HC42	21	1	800	25.0	17.6	17.50	14.50
			2	1205	35.8	25.1		13.50
C*(8,L)C*C20	HC42	21	1	745	24.8	17.0	17.50	14.50
			2	1190	35.8	25.1		13.50

For Notes See Page 10.

COOLING CAPACITY - AC8B036F1With Variable Speed Furnaces (Continued)

VARIABLE SPEED FURNACE MODEL	COIL MODEL ¹	W	COOLING					
			STAGE	RATED CFM	NET MBH		SEER	EER
					TOTAL	SENSIBLE		
1 PH 18 SEER AC WITH VARIABLE SPEED FURNACES²								
C*9C*C16	HC42	21	1	815	25.0	17.6	17.25	14.25
			2	1240	35.6	24.9		13.00
C*9C*C20	HC42	21	1	780	25.0	17.6	17.50	14.50
			2	1200	35.8	25.1		13.25
C*(8,L)C*B12	HD48	17	1	750	24.8	17.0	17.25	14.50
			2	1210	35.8	25.1		13.25
C*9C*B12	HD48	17	1	710	24.6	16.5	17.00	14.25
			2	1150	35.4	24.3		13.00
C*(8,L)C*C16	HD48	21	1	810	25.4	17.7	17.75	14.75
			2	1210	36.0	25.3		13.75
C*(8,L)C*C20	HD48	21	1	720	24.8	16.7	17.50	14.50
			2	1155	35.8	24.9		13.75
C*9C*C16	HD48	21	1	780	25.4	17.6	17.50	14.75
			2	1195	36.0	25.1		13.50
C*9C*C20	HD48	21	1	745	24.8	16.9	17.25	14.50
			2	1330	36.2	26.1		13.25
C*(8,L)C*A12	UC36A	14	1	815	24.4	16.9	16.50	13.75
			2	1190	34.0	23.3		12.25
C*(8,L)C*B12	UC36B	17	1	745	24.0	16.3	16.75	14.00
			2	1220	34.2	23.7		12.50
C*(8,L)C*C16	UC36C	21	1	805	24.6	17.0	17.25	14.25
			2	1235	34.4	23.5		13.00
C*(8,L)C*C20	UC36C	21	1	800	24.6	17.1	17.25	14.25
			2	1240	34.4	23.5		13.00
C*9C*B12	UC36B	17	1	800	24.4	17.0	16.75	14.00
			2	1165	34.2	23.5		12.75
C*9C*C16	UC36C	21	1	915	25.0	17.8	17.00	14.00
			2	1185	34.4	23.7		13.00
C*9C*C20	UC36C	21	1	760	24.2	16.5	16.75	14.00
			2	1300	34.8	24.9		12.75
C*(8,L)C*B12	UC42B	17	1	760	24.4	16.8	17.00	14.25
			2	1175	34.6	23.9		13.00
C*(8,L)C*C16	UC42C	21	1	825	24.8	17.4	17.25	14.50
			2	1205	35.0	24.5		13.50
C*(8,L)C*C20	UC42C	21	1	735	24.4	16.8	17.25	14.25
			2	1170	35.0	24.1		13.50
C*9C*B12	UC42B	17	1	800	24.8	17.3	16.75	14.00
			2	1195	34.6	24.1		12.50
C*9C*C16	UC42C	21	1	780	24.4	16.7	17.00	14.25
			2	1205	34.8	23.9		13.00
C*9C*C20	UC42C	21	1	770	24.4	16.9	17.00	14.25
			2	1325	35.4	25.1		13.00
C*(8,L)C*C16	UC48C	21	1	810	25.0	17.7	17.50	14.50
			2	1210	35.6	25.3		13.50
C*(8,L)C*C20	UC48C	21	1	720	24.4	16.7	17.25	14.25
			2	1155	35.4	24.7		13.50
C*9C*C16	UC48C	21	1	780	25.0	17.7	17.50	14.50
			2	1195	35.6	25.1		13.25
C*9C*C20	UC48C	21	1	755	24.6	17.1	17.25	14.25
			2	1330	35.8	25.9		13.00
G*9V*A12	FC/MC/PC36A	14	1	780	24.6	16.9	16.75	14.00
			2	1200	34.2	23.7		12.25
G*9V*A12	FC/MC/PC37A	14	1	800	25.0	17.5	16.75	14.00
			2	1100	34.8	23.7		12.75
G*9V*A12	UC36A	14	1	780	24.2	16.6	16.25	13.75
			2	1200	34.0	23.5		12.25

For Notes See Page 10.

COOLING CAPACITY - AC8B036F1With Variable Speed Furnaces (Continued)

VARIABLE SPEED FURNACE MODEL	COIL MODEL ¹	W	COOLING					
			STAGE	RATED CFM	NET MBH		SEER	EER
					TOTAL	SENSIBLE		
1 PH 18 SEER AC WITH VARIABLE SPEED FURNACES²								
G*9V*B12	FC/MC/PC35B	17	1	810	25.0	17.4	16.75	14.00
			2	1190	35.2	24.5		12.75
G*9V*C16	FC/MC/PC35C	21	1	790	25.0	17.5	17.25	14.25
			2	1215	35.4	24.7		13.00
G*9V*C20	FC/MC/PC35C	21	1	760	24.6	16.8	17.00	14.25
			2	1330	35.6	25.3		12.75
G*9V*B12	FC/MC/PC36B	17	1	800	25.0	17.3	17.00	14.25
			2	1165	34.8	23.9		12.75
G*9V*C16	FC/MC/PC36C	21	1	915	25.4	18.2	17.25	14.25
			2	1185	34.6	24.1		13.00
G*9V*C20	FC/MC/PC36C	21	1	760	24.6	16.8	17.25	14.25
			2	1320	35.2	25.1		12.75
G*9V*B12	FC/MC/PC42B	17	1	800	25.0	17.5	17.00	14.25
			2	1195	34.8	24.3		12.50
G*9V*C16	FC/MC/PC42C	21	1	780	24.6	16.9	17.25	14.25
			2	1205	34.8	24.3		13.25
G*9V*C20	FC/MC/PC42C	21	1	770	24.8	17.0	17.25	14.25
			2	1325	35.4	25.5		13.00
G*9V*B12	FC/MC/PC43B	17	1	815	25.0	17.5	17.00	14.25
			2	1200	35.4	24.9		12.75
G*9V*C16	FC/MC/PC43C	21	1	815	25.2	17.5	17.25	14.25
			2	1240	35.6	25.1		13.00
G*9V*C20	FC/MC/PC43C	21	1	780	24.8	16.9	17.25	14.25
			2	1200	35.8	25.1		13.25
G*9V*C16	FC/MC/PC48C	21	1	780	25.6	17.9	17.75	14.75
			2	1195	36.2	25.5		13.50
G*9V*C20	FC/MC/PC48C	21	1	745	24.8	17.1	17.50	14.50
			2	1330	36.6	26.5		13.25
G*9V*C16	HC42	21	1	815	25.0	17.6	17.25	14.25
			2	1240	35.6	24.9		13.00
G*9V*C20	HC42	21	1	780	25.0	17.6	17.50	14.50
			2	1200	35.8	25.1		13.25
G*9V*B12	HD48	17	1	710	24.6	16.5	17.00	14.25
			2	1150	35.4	24.3		13.00
G*9V*C16	HD48	21	1	780	25.4	17.6	17.50	14.75
			2	1195	36.0	25.1		13.50
G*9V*C20	HD48	21	1	745	24.8	16.9	17.25	14.50
			2	1330	36.2	26.1		13.25
G*9V*B12	UC36B	17	1	800	24.4	17.0	16.75	14.00
			2	1165	34.2	23.5		12.75
G*9V*C16	UC36C	21	1	915	25.0	17.8	17.00	14.00
			2	1185	34.4	23.7		13.00
G*9V*C20	UC36C	21	1	760	24.2	16.5	16.75	14.00
			2	1300	34.8	24.9		12.75
G*9V*B12	UC42B	17	1	800	24.8	17.3	16.75	14.00
			2	1195	34.6	24.1		12.50
G*9V*C16	UC42C	21	1	780	24.4	16.7	17.00	14.25
			2	1205	34.8	23.9		13.00
G*9V*C20	UC42C	21	1	770	24.4	16.9	17.00	14.25
			2	1325	35.4	25.1		13.00
G*9V*C16	UC48C	21	1	780	25.0	17.7	17.50	14.50
			2	1195	35.6	25.1		13.25
G*9V*C20	UC48C	21	1	755	24.6	17.1	17.25	14.25
			2	1330	35.8	25.9		13.00

1 MC coils available with a factory installed horizontal drain pan.

2 Variable speed furnaces have B.O.D (Blower on Delay) standard.

COOLING CAPACITY - AC8B048F1With Variable Speed Furnaces

VARIABLE SPEED FURNACE MODEL	COIL MODEL ¹	W	COOLING					
			STAGE	RATED CFM	NET MBH		SEER	EER
					TOTAL	SENSIBLE		
1 PH 18 SEER AC WITH VARIABLE SPEED FURNACES²								
(F,L)C8V*C16	FC/MC/PC48C	21	1	880	33.0	24.4	16.90	13.90
			2	1500	45.0	34.4		11.95
(F,L)C8V*C16	UC48D	21	1	880	33.0	24.4	16.90	13.90
			2	1500	45.0	34.4		11.95
(F,L)C8V*C20	FC/MC/PC48C	21	1	1030	34.1	25.2	17.10	14.15
			2	1610	45.5	34.8		12.05
(F,L)C8V*C20	UC48D	21	1	1030	34.1	25.2	17.10	14.15
			2	1610	45.5	34.8		12.05
(F,L)C9(C,V)*C16	FC/MC/PC48C	21	1	1090	34.6	25.6	17.50	14.50
			2	1600	45.5	34.8		11.85
(F,L)C9(C,V)*C16	UC48D	21	1	1090	34.6	25.6	17.50	14.50
			2	1600	45.5	34.8		11.85
(F,L)C9(C,V)*C20	FC/MC/PC48C	21	1	1010	33.9	25.0	16.90	13.95
			2	1580	45.5	34.8		12.05
(F,L)C9(C,V)*C20	UC48D	21	1	1010	33.9	25.0	16.90	13.95
			2	1580	45.5	34.8		12.05
(F,L)C9(C,V)*D20	FC/MC/PC48D	24	1	985	33.8	25.0	16.95	13.95
			2	1560	45.5	34.8		12.20
(F,L)C9(C,V)*D20	UC48D	24	1	985	33.8	25.0	16.95	13.95
			2	1560	45.5	34.8		12.20
(F,L)C8V*C20	FC/MC62D	21	1	1030	34.2	25.3	17.20	14.25
			2	1610	46.0	35.1		12.20
(F,L)C9(C,V)*C20	FC/MC62D	21	1	1010	34.1	25.2	16.80	14.00
			2	1580	46.0	35.1		12.15
(F,L)C9(C,V)*D20	FC/MC62D	24	1	985	33.9	25.0	17.00	14.00
			2	1560	46.0	35.1		12.30
(F,L)C9(C,V)*D20	HC60D	24	1	985	32.3	23.9	16.25	13.25
			2	1560	44.0	33.6		11.85
C*(8,L)C*C16	FC/MC/PC48C	21	1	1035	33.4	24.6	16.50	13.50
			2	1615	45.5	34.6		11.75
C*(8,L)C*C20	FC/MC/PC48C	21	1	1080	33.4	24.4	16.25	13.50
			2	1640	45.5	34.4		11.75
C*9C*C16	FC/MC/PC48C	21	1	1050	33.4	24.6	16.25	13.50
			2	1590	45.5	34.1		11.75
C*9C*C20	FC/MC/PC48C	21	1	1055	33.4	24.6	16.50	13.50
			2	1655	45.5	34.1		11.75
C*9C*D20	FC/MC/PC48D	24	1	1060	33.0	24.2	16.25	13.25
			2	1645	45.0	34.0		11.50
C*(8,L)C*C16	FC/PC60C	21	1	1035	32.6	23.8	16.25	13.25
			2	1625	44.5	33.8		11.75
C*(8,L)C*C20	FC/PC60C	21	1	1015	32.6	23.8	16.25	13.50
			2	1605	45.0	34.0		12.00
C*9C*C16	FC/PC60C	21	1	1050	32.4	23.8	16.00	13.25
			2	1590	44.5	33.6		11.50
C*9C*C20	FC/PC60C	21	1	1055	32.6	23.8	16.00	13.25
			2	1655	44.5	33.6		11.50
C*9C*D20	FC/MC/PC60D	24	1	1070	32.4	23.8	16.00	13.25
			2	1615	44.5	33.8		11.75
C*9C*D20	FC/MC62D	24	1	1085	33.0	24.4	16.25	13.50
			2	1630	45.0	34.0		11.75
C*9C*D20	HC60	24	1	1070	32.0	23.6	15.75	13.00
			2	1615	44.0	33.6		11.50
C*(8,L)C*C16	HD48	21	1	1035	32.8	24.0	16.25	13.50
			2	1615	45.5	33.9		11.75

For Notes See Page 13.

COOLING CAPACITY - AC8B048F1With Variable Speed Furnaces (Continued)

VARIABLE SPEED FURNACE MODEL	COIL MODEL ¹	W	COOLING					
			STAGE	RATED CFM	NET MBH		SEER	EER
					TOTAL	SENSIBLE		
1 PH 18 SEER AC WITH VARIABLE SPEED FURNACES²								
C*(8,L)C*C20	HD48	21	1	1080	32.8	24.0	16.00	13.25
			2	1640	45.5	33.7		11.75
C*9C*C16	HD48	21	1	1050	33.0	24.0	16.25	13.25
			2	1590	45.0	33.5		11.75
C*9C*C20	HD48	21	1	1055	33.0	24.0	16.25	13.50
			2	1655	45.0	33.5		11.75
C*9C*D20	HD48	24	1	1060	32.8	24.0	16.25	13.25
			2	1645	45.5	33.7		11.75
C*(8,L)C*C16	HD60	21	1	1035	33.6	24.6	16.75	13.75
			2	1625	45.5	34.6		12.00
C*(8,L)C*C20	HD60	21	1	1015	33.6	24.6	16.75	14.00
			2	1605	45.5	34.8		12.00
C*9C*C16	HD60	21	1	1050	33.4	24.6	16.25	13.50
			2	1590	45.5	34.6		11.75
C*9C*C20	HD60	21	1	1055	33.6	24.6	16.50	13.75
			2	1655	45.5	34.6		11.75
C*9C*D20	HD60	24	1	1070	33.6	24.6	16.50	13.50
			2	1615	45.5	34.6		11.75
C*(8,L)C*C16	UC48C	21	1	1035	31.8	23.4	15.75	13.00
			2	1615	44.0	33.4		11.50
C*(8,L)C*C20	UC48C	21	1	1080	31.8	23.4	15.50	12.75
			2	1640	44.0	33.4		11.50
C*9C*C16	UC48C	21	1	1050	31.8	23.8	15.50	12.75
			2	1590	43.5	33.0		11.25
C*9C*C20	UC48C	21	1	1055	31.8	23.8	15.75	12.75
			2	1630	43.5	33.0		11.25
C*9C*D20	UC48D	24	1	1060	29.8	22.0	14.75	12.00
			2	1570	42.0	31.1		11.00
C*(8,L)C*C16	UC60C	21	1	1035	30.0	21.4	15.00	12.25
			2	1570	42.0	31.1		11.25
C*(8,L)C*C20	UC60C	21	1	1015	30.0	21.4	15.00	12.25
			2	1590	42.5	31.3		11.50
C*9C*C16	UC60C	21	1	1050	30.0	21.2	14.75	12.00
			2	1570	42.0	31.1		11.00
C*9C*C20	UC60C	21	1	1055	30.0	21.4	14.75	12.00
			2	1570	42.0	31.1		11.00
C*9C*D20	UC60D	24	1	1070	30.0	21.2	14.75	12.00
			2	1570	42.0	31.1		11.00
G*9V*C16	FC/MC/PC48C	21	1	1050	33.4	24.6	16.25	13.50
			2	1590	45.5	34.1		11.75
G*9V*C20	FC/MC/PC48C	21	1	1055	33.4	24.6	16.50	13.50
			2	1655	45.5	34.1		11.75
G*9V*D20	FC/MC/PC48D	24	1	1060	33.0	24.2	16.25	13.25
			2	1645	45.0	34.0		11.50
G*9V*C16	FC/PC60C	21	1	1050	32.4	23.8	16.00	13.25
			2	1590	44.5	33.6		11.50
G*9V*C20	FC/PC60C	21	1	1055	32.6	23.8	16.00	13.25
			2	1655	44.5	33.6		11.50
G*9V*D20	FC/MC/PC60D	24	1	1070	32.4	23.8	16.00	13.25
			2	1615	44.5	33.8		11.75
G*9V*D20	FC/MC62D	24	1	1085	33.0	24.4	16.25	13.50
			2	1630	45.0	34.0		11.75
G*9V*D20	HC60	24	1	1070	32.0	23.6	15.75	13.00
			2	1615	44.0	33.6		11.50
G*9V*C16	HD48	21	1	1050	33.0	24.0	16.25	13.25
			2	1590	45.0	33.5		11.75

For Notes See Page 13.

COOLING CAPACITY - AC8B048F1With Variable Speed Furnaces (Continued)

VARIABLE SPEED FURNACE MODEL	COIL MODEL ¹	W	COOLING					
			STAGE	RATED CFM	NET MBH		SEER	EER
					TOTAL	SENSIBLE		
1 PH 18 SEER AC WITH VARIABLE SPEED FURNACES²								
G*9V*C20	HD48	21	1	1055	33.0	24.0	16.25	13.50
			2	1655	45.0	33.5		11.75
G*9V*D20	HD48	24	1	1060	32.8	24.0	16.25	13.25
			2	1645	45.5	33.7		11.75
G*9V*C16	HD60	21	1	1050	33.4	24.6	16.25	13.50
			2	1590	45.5	34.6		11.75
G*9V*C20	HD60	21	1	1055	33.6	24.6	16.50	13.75
			2	1655	45.5	34.6		11.75
G*9V*D20	HD60	24	1	1070	33.6	24.6	16.50	13.50
			2	1615	45.5	34.6		11.75
G*9V*C16	UC48C	21	1	1050	31.8	23.8	15.50	12.75
			2	1590	43.5	33.0		11.25
G*9V*C20	UC48C	21	1	1055	31.8	23.8	15.75	12.75
			2	1630	43.5	33.0		11.25
G*9V*D20	UC48D	24	1	1060	29.8	22.0	14.75	12.00
			2	1570	42.0	31.1		11.00
G*9V*C16	UC60C	21	1	1050	30.0	21.2	14.75	12.00
			2	1570	42.0	31.1		11.00
G*9V*C20	UC60C	21	1	1055	30.0	21.4	14.75	12.00
			2	1570	42.0	31.1		11.00
G*9V*D20	UC60D	24	1	1070	30.0	21.2	14.75	12.00
			2	1570	42.0	31.1		11.00

1 MC coils available with a factory installed horizontal drain pan.

2 Variable speed furnaces have B.O.D (Blower on Delay) standard.

COOLING CAPACITY - AC8B060F1 With Variable Speed Furnaces

VARIABLE SPEED FURNACE MODEL	COIL MODEL ¹	W	COOLING					
			STAGE	RATED CFM	NET MBH		SEER	EER
					TOTAL	SENSIBLE		
1 PH 18 SEER AC WITH VARIABLE SPEED FURNACES²								
(F,L)C8V*C20	FC/PC60C	21	1	1120	41.0	27.8	15.45	12.75
			2	1730	55.0	40.1		11.40
(F,L)C8V*C20	UC60D	21	1	1120	41.0	27.8	15.45	12.75
			2	1730	55.0	40.1		11.40
(F,L)C9(C,V)*C20	FC/PC60C	21	1	1075	40.4	27.4	15.25	12.55
			2	1650	54.0	39.4		11.25
(F,L)C9(C,V)*C20	UC60D	21	1	1075	40.4	27.4	15.25	12.55
			2	1650	54.0	39.4		11.25
(F,L)C9(C,V)*D20	FC/MC/PC60D	24	1	1020	40.2	27.3	15.25	12.55
			2	1620	54.0	39.4		11.45
(F,L)C9(C,V)*D20	UC60D	24	1	1020	40.2	27.3	15.25	12.55
			2	1620	54.0	39.4		11.45
(F,L)C8V*C20	FC/MC62D	21	1	1120	42.8	29.1	16.10	13.35
			2	1730	57.0	41.6		11.70
(F,L)C9(C,V)*C20	FC/MC62D	21	1	1075	42.4	28.8	15.95	13.25
			2	1650	56.5	41.2		11.65
(F,L)C9(C,V)*D20	FC/MC62D	24	1	1020	42.0	28.5	15.90	13.20
			2	1620	56.5	41.2		11.80
(F,L)C9(C,V)*D20	HC60D	24	1	1020	40.1	27.2	15.30	12.55
			2	1620	54.5	39.7		11.50
C*(8,L)C*C20	FC/PC60C	21	1	1015	40.0	26.0	15.25	12.50
			2	1605	55.0	36.1		11.25
C*9C*C20	FC/PC60C	21	1	1055	40.0	25.8	15.00	12.25
			2	1655	54.5	35.9		11.00

For Notes See Page 14.

COOLING CAPACITY - AC8B060F1 With Variable Speed Furnaces (Continued)

VARIABLE SPEED FURNACE MODEL	COIL MODEL ¹	W	COOLING					
			STAGE	RATED CFM	NET MBH		SEER	EER
					TOTAL	SENSIBLE		
1 PH 18 SEER AC WITH VARIABLE SPEED FURNACES²								
C*9C*D20	FC/MC62D	24	1	1085	40.5	26.3	15.00	12.50
			2	1630	55.0	36.3		11.25
C*9C*D20	HC60	24	1	1070	39.0	25.4	14.50	12.00
			2	1615	53.5	34.9		10.75
C*(8,L)C*C20	HD60	21	1	1015	40.5	25.8	15.25	12.50
			2	1605	55.5	36.1		11.50
C*9C*C20	HD60	21	1	1055	40.5	26.3	15.25	12.50
			2	1655	55.5	36.3		11.00
C*9C*D20	HD60	24	1	1070	40.5	26.5	15.25	12.50
			2	1615	54.5	35.5		11.00
C*(8,L)C*C20	UC60C	21	1	1015	38.5	24.6	14.50	12.00
			2	1605	53.5	34.6		11.00
C*9C*C20	UC60C	21	1	1055	38.5	24.6	14.25	11.75
			2	1655	53.0	34.4		10.75
C*9C*D20	UC60D	24	1	1070	38.5	25.0	14.50	11.75
			2	1615	53.5	34.6		10.75
G*9V*C20	FC/PC60C	21	1	1055	40.0	25.8	15.00	12.25
			2	1655	54.5	35.9		11.00
G*9V*D20	FC/MC62D	24	1	1085	40.5	26.3	15.00	12.50
			2	1630	55.0	36.3		11.25
G*9V*D20	HC60	24	1	1070	39.0	25.4	14.50	12.00
			2	1615	53.5	34.9		10.75
G*9V*C20	HD60	21	1	1055	40.5	26.3	15.25	12.50
			2	1655	55.5	36.3		11.00
G*9V*D20	HD60	24	1	1070	40.5	26.5	15.25	12.50
			2	1615	54.5	35.5		11.00
G*9V*C20	UC60C	21	1	1055	38.5	24.6	14.25	11.75
			2	1655	53.0	34.4		10.75
G*9V*D20	UC60D	24	1	1070	38.5	25.0	14.50	11.75
			2	1615	53.5	34.6		10.75

- 1 MC coils available with a factory installed horizontal drain pan.
2 Variable speed furnaces have B.O.D (Blower on Delay) standard.

ACCESSORIES*

Hard Start Kit (024-31994-000, 024-31995-000) - Provides increased starting torque for areas with low voltage.

TXV Kits - 1TVM9 series thermal expansion valves precisely meter refrigerant for optimum performance

Dehumidistat (2HU16700124) - Provides increased dehumidification when matched with variable speed furnace or air handler.

Room Thermostats - A wide selection of compatible thermostats are available to provide optimum performance and features for any installation.

1 Heat Stage only, manual, mechanical thermostat. Add sub-base for 3H/2C.

3H/2C, manual changeover electronic non-programmable thermostat.

3H/2C, auto/manual changeover, electronic programmable, deluxe 7-day, thermostat.

3H/2C, auto/manual changeover, electronic programmable.

* For the most current accessory information, refer to the price book or consult factory.

SOUND POWER RATINGS*

UNIT MODEL	(dBA)
024	71
036	73
048	72
060	74

* Rated in accordance with ARI 270-95 Standards.

COOLING PERFORMANCE DATA - LOW CFM 1-STAGE OPERATION																
OUTDOOR UNIT MODEL NO.		AC8B024F1														
INDOOR COIL MODEL NO.		FC48D + MV12D														
CONDENSER ENTERING AIR TEMPERATURE	ID CFM	550					600					650				
	ID DB (°F)	80	80	75	80	80	80	80	75	80	80	80	80	75	80	80
	ID WB (°F)	57	62	62	67	72	57	62	62	67	72	57	62	62	67	72
65	T.C.	18.6	19.9	18.9	21.7	23.9	19.0	19.9	19.1	21.8	24.4	19.4	20.0	19.3	22.0	24.9
	S.C.	18.6	17.5	14.9	14.8	11.7	19.2	18.5	15.6	15.5	12.1	19.7	19.4	16.2	16.2	12.5
	K.W.	0.76	0.75	0.76	0.74	0.74	0.75	0.75	0.75	0.73	0.74	0.75	0.75	0.75	0.73	0.74
75	T.C.	17.8	18.8	18.0	20.6	22.8	18.3	18.9	18.3	20.9	23.2	18.7	19.1	18.5	21.1	23.6
	S.C.	17.9	17.1	14.5	14.4	11.3	18.4	17.9	15.1	15.1	11.8	18.9	18.6	15.8	15.9	12.2
	K.W.	0.93	0.92	0.93	0.91	0.90	0.92	0.92	0.92	0.90	0.90	0.91	0.91	0.92	0.90	0.90
85	T.C.	17.1	17.6	17.1	19.5	21.6	17.5	17.9	17.4	19.9	22.0	17.9	18.2	17.7	20.2	22.3
	S.C.	17.2	16.8	14.0	14.0	10.9	17.7	17.3	14.7	14.8	11.4	18.1	17.9	15.4	15.5	11.9
	K.W.	1.09	1.09	1.09	1.08	1.06	1.08	1.08	1.09	1.07	1.06	1.07	1.08	1.08	1.06	1.05
95	T.C.	16.4	16.5	16.2	18.5	20.5	16.8	16.9	16.6	18.9	20.8	17.1	17.2	16.9	19.4	21.0
	S.C.	16.5	16.4	13.6	13.7	10.5	17.0	16.8	14.3	14.4	11.1	17.4	17.2	15.0	15.1	11.7
	K.W.	1.26	1.26	1.26	1.24	1.22	1.24	1.25	1.25	1.24	1.22	1.24	1.24	1.25	1.23	1.21
105	T.C.	15.3	15.4	14.9	17.0	19.0	15.7	15.8	15.2	17.3	19.1	16.0	16.2	15.5	17.7	19.3
	S.C.	15.4	15.2	13.0	13.2	10.1	15.8	15.6	13.6	13.9	10.5	16.2	16.0	14.3	14.5	11.0
	K.W.	1.48	1.49	1.49	1.47	1.45	1.47	1.48	1.48	1.47	1.45	1.46	1.47	1.48	1.46	1.45
115	T.C.	14.2	14.3	13.6	15.5	17.5	14.6	14.7	13.9	15.8	17.6	15.0	15.1	14.1	16.1	17.7
	S.C.	14.4	14.1	12.4	12.8	9.6	14.7	14.5	13.0	13.4	10.0	15.1	14.9	13.5	13.9	10.4
	K.W.	1.70	1.71	1.71	1.70	1.68	1.69	1.70	1.70	1.69	1.67	1.68	1.69	1.70	1.68	1.67
125	T.C.	13.1	13.2	12.3	14.0	15.9	13.5	13.6	12.5	14.3	16.0	13.9	14.0	12.7	14.5	16.1
	S.C.	13.3	13.0	11.8	12.3	9.2	13.6	13.4	12.3	12.9	9.5	14.0	13.8	12.8	13.4	9.7
	K.W.	1.92	1.93	1.93	1.92	1.91	1.91	1.92	1.93	1.91	1.90	1.91	1.91	1.92	1.91	1.90

NOTE: ALL CAPACITIES ARE NET (KBTUH) WITH INDOOR FAN HEAT ALREADY DEDUCTED AT 1250 BTUH/1000 CFM.

Multipliers for determining the performance with other indoor sections.

NOTE: For dry bulb temperatures different than those listed (between 73-87 F), sensible capacity increases by 1060 BTUH per 1000 CFM per degree above the listed temperature and decreases by 1060 BTUH per 1000 CFM per degree below the listed temperature.

NOTE: KW RATING IS FOR OUTDOOR AND INDOOR UNITS.

LOW CFM

Air Handler	Coil	T.C.	S.C.	KW
AV36C	-	0.97	0.97	0.99
MV12B	FC/MC/PC35B	0.96	0.97	1.01
MV12B	FC/MC/PC35C	0.96	0.97	1.01
MV12B	FC/MC/PC35B	0.98	0.98	1.02
MV12B	FC/MC/PC35C	0.98	0.98	1.02
MV12D	FC/MC/PC48D	1.00	1.00	1.00

Variable Speed Furnace	Coil	T.C.	S.C.	KW
(F,L)C8V*A12	FC/MC/PC32A	0.91	0.91	0.98
(F,L)C9V*A12	FC/MC/PC32A	0.96	0.96	1.02
(F,L)C9(C,V)*B12	FC/MC/PC35B	0.95	0.95	0.99
(F,L)C8V*A12	FC/MC/PC37A	0.92	0.92	0.98
(F,L)C9V*A12	FC/MC/PC37A	0.98	0.99	1.03
(F,L)C9(C,V)*B12	FC/MC/PC43B	0.96	0.96	0.99
(F,L)C9(C,V)*B12	HC36B	0.95	0.95	0.99
C*(8,L)C*A12	FC/MC/PC30A	0.95	0.91	1.01
C*(8,L)C*B12	FC/MC/PC30B	0.96	0.92	1.00
C*9C*B12	FC/MC/PC30B	0.95	0.91	1.01
C*(8,L)C*A12	FC/MC/PC32A	0.94	0.89	1.01
C*(8,L)C*B12	FC/MC/PC35B	0.93	0.86	1.00
C*9C*B12	FC/MC/PC35B	0.94	0.89	1.00
C*(8,L)C*A12	FC/MC/PC36A	0.96	0.92	1.00
C*(8,L)C*B12	FC/MC/PC36B	0.94	0.88	0.99
C*9C*B12	FC/MC/PC36B	0.96	0.92	1.01
C*(8,L)C*A12	FC/MC/PC37A	0.97	0.93	1.02
C*(8,L)C*B12	FC/MC/PC43B	0.94	0.88	0.99

Variable Speed Furnace	Coil	T.C.	S.C.	KW
C*9C*B12	FC/MC/PC43B	0.96	0.90	1.00
C*(8,L)C*A12	HC30	0.93	0.88	1.01
C*(8,L)C*A12	HD36	0.94	0.88	1.01
C*(8,L)C*B12	HD36	0.91	0.83	1.00
C*9C*B12	HD36	0.94	0.88	1.01
C*(8,L)C*A12	UC30A	0.95	0.92	1.01
C*(8,L)C*B12	UC30B	0.96	0.92	1.00
C*9C*B12	UC30B	0.95	0.92	1.01
C*(8,L)C*A12	UC36A	0.91	0.89	1.01
C*(8,L)C*B12	UC36B	0.89	0.83	1.00
C*9C*B12	UC36B	0.91	0.89	1.01
G*9V*A12	FC/MC/PC30A	0.96	0.93	1.03
G*9V*B12	FC/MC/PC30B	0.95	0.91	1.01
G*9V*A12	FC/MC/PC32A	0.96	0.94	1.03
G*9V*B12	FC/MC/PC35B	0.94	0.89	1.00
G*9V*A12	FC/MC/PC36A	0.96	0.94	1.03
G*9V*B12	FC/MC/PC36B	0.96	0.92	1.01
G*9V*A12	FC/MC/PC37A	0.94	0.88	1.02
G*9V*B12	FC/MC/PC43B	0.96	0.90	1.00
G*9V*A12	HC30	0.95	0.92	1.03
G*9V*A12	HD36	0.95	0.88	1.03
G*9V*B12	HD36	0.94	0.88	1.01
G*9V*A12	UC30A	0.97	0.94	1.03
G*9V*B12	UC30B	0.95	0.92	1.01
G*9V*A12	UC36A	0.92	0.89	1.03
G*9V*B12	UC36B	0.91	0.89	1.01

COOLING PERFORMANCE DATA - HIGH CFM 2-STAGE OPERATION																
OUTDOOR UNIT MODEL NO.		AC8B024F1														
INDOOR COIL MODEL NO.		FC48D + MV12D														
CONDENSER ENTERING AIR TEMPERATURE	ID CFM	700					800					900				
	ID DB (°F)	80	80	75	80	80	80	80	75	80	80	80	80	75	80	80
	ID WB (°F)	57	62	62	67	72	57	62	62	67	72	57	62	62	67	72
65	T.C.	23.1	25.7	25.0	28.6	30.7	24.3	26.0	26.1	28.8	31.1	25.5	26.3	27.1	28.9	31.6
	S.C.	22.6	21.4	17.9	18.3	14.5	23.8	23.1	19.5	19.1	15.3	25.0	24.8	21.0	20.0	16.1
	K.W.	1.12	1.14	1.14	1.16	1.17	1.13	1.14	1.14	1.16	1.18	1.15	1.15	1.15	1.17	1.19
75	T.C.	22.5	24.3	23.9	27.1	29.2	23.5	24.7	24.7	27.4	29.7	24.5	25.1	25.5	27.6	30.1
	S.C.	21.9	20.9	17.5	17.8	14.0	23.0	22.4	18.9	18.7	14.8	24.0	23.8	20.3	19.7	15.5
	K.W.	1.31	1.32	1.32	1.34	1.35	1.31	1.32	1.32	1.34	1.36	1.33	1.33	1.33	1.35	1.37
85	T.C.	21.8	22.9	22.8	25.6	27.7	22.6	23.4	23.4	26.0	28.2	23.4	23.8	23.9	26.4	28.7
	S.C.	21.3	20.4	17.2	17.3	13.6	22.1	21.6	18.4	18.4	14.3	22.9	22.7	19.6	19.4	15.0
	K.W.	1.49	1.50	1.50	1.52	1.53	1.49	1.50	1.50	1.52	1.54	1.51	1.51	1.51	1.54	1.55
95	T.C.	21.2	21.5	21.8	24.0	26.2	21.8	22.1	22.1	24.6	26.7	22.4	22.5	22.3	25.2	27.2
	S.C.	20.6	20.0	16.8	16.8	13.1	21.3	20.9	17.9	18.0	13.7	21.9	21.7	18.9	19.1	14.4
	K.W.	1.67	1.68	1.67	1.70	1.72	1.67	1.68	1.68	1.70	1.72	1.69	1.69	1.69	1.72	1.73
105	T.C.	20.1	20.3	20.4	22.6	24.5	20.6	20.9	20.7	23.0	25.0	21.2	21.4	20.9	23.5	25.5
	S.C.	19.5	19.0	16.2	16.3	12.6	20.1	19.8	17.2	17.3	13.2	20.7	20.5	18.2	18.4	13.8
	K.W.	1.93	1.93	1.93	1.95	1.97	1.93	1.94	1.93	1.96	1.98	1.95	1.95	1.94	1.97	1.99
115	T.C.	19.0	19.2	19.1	21.2	22.9	19.5	19.7	19.3	21.5	23.4	20.0	20.2	19.5	21.8	23.9
	S.C.	18.5	18.1	15.5	15.8	12.0	19.0	18.8	16.6	16.7	12.6	19.6	19.4	17.6	17.6	13.2
	K.W.	2.17	2.18	2.17	2.20	2.23	2.18	2.18	2.18	2.21	2.23	2.20	2.20	2.19	2.22	2.24
125	T.C.	17.9	18.0	17.7	19.8	21.3	18.4	18.5	17.9	20.0	21.8	18.9	19.1	18.1	20.2	22.2
	S.C.	17.4	17.2	14.9	15.3	11.5	17.9	17.8	15.9	16.1	12.1	18.4	18.3	16.9	16.9	12.6
	K.W.	2.42	2.42	2.42	2.45	2.48	2.43	2.43	2.42	2.45	2.48	2.45	2.45	2.44	2.47	2.50

NOTE: ALL CAPACITIES ARE NET (KBTUH) WITH INDOOR FAN HEAT ALREADY DEDUCTED AT 1250 BTUH/1000 CFM.

Multipliers for determining the performance with other indoor sections.

NOTE: For dry bulb temperatures different than those listed (between 73-87 F), sensible capacity increases by 1060 BTUH per 1000 CFM per degree above the listed temperature and decreases by 1060 BTUH per 1000 CFM per degree below the listed temperature.

NOTE: KW RATING IS FOR OUTDOOR AND INDOOR UNITS.

HIGH CFM

Air Handler	Coil	T.C.	S.C.	KW
AV36C	-	0.97	0.97	0.99
MV12B	FC/MC/PC35B	0.96	0.96	1.00
MV12B	FC/MC/PC35C	0.96	0.96	1.00
MV12B	FC/MC/PC35B	0.98	0.98	1.01
MV12B	FC/MC/PC35C	0.98	0.98	1.01
MV12D	FC/MC/PC48D	1.00	1.00	1.00
MV12D	UC48D	1.00	1.00	1.00

Variable Speed Furnace	Coil	T.C.	S.C.	KW
(F,L)C8V*A12	FC/MC/PC32A	0.94	0.94	1.01
(F,L)C9V*A12	FC/MC/PC32A	0.94	0.94	1.04
(F,L)C9(C,V)*B12	FC/MC/PC35B	0.95	0.95	1.02
(F,L)C9(C,V)*B12	FC/MC/PC35C	0.95	0.95	1.02
(F,L)C8V*A12	FC/MC/PC37A	0.96	0.96	1.01
(F,L)C9V*A12	FC/MC/PC37A	0.96	0.96	1.04
(F,L)C9(C,V)*B12	FC/MC/PC43B	0.98	0.98	1.03
(F,L)C9(C,V)*B12	HC36B	0.95	0.95	1.01
C*(8,L)C*A12	FC/MC/PC30A	0.95	0.92	1.01
C*(8,L)C*B12	FC/MC/PC30B	0.96	0.92	1.00
C*9C*B12	FC/MC/PC30B	0.95	0.92	1.01
C*(8,L)C*A12	FC/MC/PC32A	0.95	0.92	1.02
C*(8,L)C*B12	FC/MC/PC35B	0.95	0.91	1.00
C*9C*B12	FC/MC/PC35B	0.96	0.94	1.02
C*(8,L)C*A12	FC/MC/PC36A	0.95	0.93	1.01
C*(8,L)C*B12	FC/MC/PC36B	0.95	0.92	0.99
C*9C*B12	FC/MC/PC36B	0.96	0.94	1.01
C*(8,L)C*A12	FC/MC/PC37A	0.97	0.95	1.02

Variable Speed Furnace	Coil	T.C.	S.C.	KW
C*(8,L)C*B12	FC/MC/PC43B	0.97	0.93	1.00
C*9C*B12	FC/MC/PC43B	0.97	0.95	1.01
C*(8,L)C*A12	HC30	0.94	0.90	1.02
C*(8,L)C*A12	HD36	0.95	0.89	1.01
C*(8,L)C*B12	HD36	0.94	0.88	1.00
C*9C*B12	HD36	0.95	0.89	1.00
C*(8,L)C*A12	UC30A	0.96	0.92	1.01
C*(8,L)C*B12	UC30B	0.96	0.93	1.00
C*9C*B12	UC30B	0.96	0.92	1.01
C*(8,L)C*A12	UC36A	0.92	0.89	1.00
C*(8,L)C*B12	UC36B	0.92	0.88	0.99
C*9C*B12	UC36B	0.92	0.89	1.00
G*9V*A12	FC/MC/PC30A	0.95	0.92	1.02
G*9V*B12	FC/MC/PC30B	0.95	0.92	1.01
G*9V*A12	FC/MC/PC32A	0.95	0.92	1.04
G*9V*B12	FC/MC/PC35B	0.96	0.94	1.02
G*9V*A12	FC/MC/PC36A	0.95	0.92	1.02
G*9V*B12	FC/MC/PC36B	0.96	0.94	1.01
G*9V*A12	FC/MC/PC37A	0.97	0.94	1.03
G*9V*B12	FC/MC/PC43B	0.97	0.95	1.01
G*9V*A12	HC30	0.95	0.91	1.02
G*9V*A12	HD36	0.94	0.88	1.02
G*9V*B12	HD36	0.95	0.89	1.00
G*9V*A12	UC30A	0.96	0.92	1.02
G*9V*B12	UC30B	0.96	0.92	1.01
G*9V*A12	UC36A	0.92	0.88	1.02
G*9V*B12	UC36B	0.92	0.89	1.00

COOLING PERFORMANCE DATA - LOW CFM 1-STAGE OPERATION																
OUTDOOR UNIT MODEL NO.		AC8B036F1														
INDOOR COIL MODEL NO.		FC62D + MV12D														
CONDENSER ENTERING AIR TEMPERATURE	ID CFM	750					800					850				
	ID DB (°F)	80	80	75	80	80	80	80	75	80	80	80	80	75	80	80
	ID WB (°F)	57	62	62	67	72	57	62	62	67	72	57	62	62	67	72
65	T.C.	25.4	26.8	27.2	29.7	32.8	25.9	27.0	27.3	30.1	33.0	26.4	27.2	27.5	30.4	33.2
	S.C.	25.0	22.9	19.4	19.3	15.3	25.6	23.7	19.9	19.8	15.7	26.1	24.6	20.4	20.2	16.1
	K.W.	1.00	0.99	0.99	0.96	0.93	0.99	0.98	0.98	0.95	0.92	0.97	0.97	0.97	0.94	0.91
75	T.C.	24.3	25.5	25.7	28.3	31.2	24.9	25.7	25.9	28.6	31.3	25.4	26.0	26.1	28.9	31.5
	S.C.	24.0	22.3	18.8	18.7	14.8	24.6	23.1	19.4	19.2	15.3	25.1	23.8	19.9	19.7	15.7
	K.W.	1.24	1.23	1.23	1.20	1.17	1.22	1.22	1.22	1.19	1.16	1.21	1.21	1.21	1.18	1.16
85	T.C.	23.3	24.2	24.3	26.9	29.5	23.8	24.5	24.5	27.2	29.7	24.3	24.7	24.8	27.5	29.8
	S.C.	23.0	21.8	18.3	18.2	14.4	23.6	22.4	18.8	18.7	14.9	24.1	23.0	19.3	19.2	15.3
	K.W.	1.47	1.47	1.47	1.44	1.41	1.46	1.46	1.46	1.43	1.41	1.45	1.45	1.45	1.42	1.40
95	T.C.	22.2	22.9	22.8	25.4	27.9	22.7	23.2	23.1	25.8	28.0	23.3	23.5	23.4	26.1	28.2
	S.C.	22.0	21.2	17.7	17.6	14.0	22.6	21.7	18.2	18.2	14.5	23.1	22.2	18.8	18.7	14.9
	K.W.	1.71	1.71	1.71	1.68	1.65	1.70	1.70	1.70	1.67	1.65	1.69	1.69	1.69	1.66	1.64
105	T.C.	20.8	21.3	21.0	23.6	26.0	21.3	21.7	21.3	23.8	26.1	21.9	22.1	21.5	24.1	26.2
	S.C.	20.6	20.0	16.8	16.8	13.4	21.2	20.5	17.4	17.4	13.7	21.7	21.0	17.9	17.9	14.1
	K.W.	2.03	2.03	2.03	2.01	1.98	2.02	2.02	2.02	2.00	1.97	2.00	2.01	2.01	1.99	1.97
115	T.C.	19.4	19.7	19.3	21.7	24.1	20.0	20.2	19.5	22.0	24.2	20.5	20.7	19.7	22.2	24.3
	S.C.	19.2	18.8	16.0	16.1	12.8	19.8	19.3	16.6	16.6	13.0	20.4	19.8	17.1	17.1	13.3
	K.W.	2.34	2.33	2.34	2.32	2.30	2.33	2.33	2.33	2.31	2.29	2.31	2.32	2.32	2.30	2.28
125	T.C.	18.0	18.2	17.5	19.9	22.2	18.6	18.8	17.7	20.1	22.3	19.1	19.3	18.0	20.4	22.4
	S.C.	17.8	17.6	15.2	15.3	12.2	18.4	18.1	15.8	15.8	12.3	19.0	18.5	16.4	16.3	12.5
	K.W.	2.65	2.64	2.65	2.63	2.62	2.64	2.64	2.65	2.63	2.61	2.62	2.63	2.64	2.62	2.60

NOTE: ALL CAPACITIES ARE NET (KBTUH) WITH INDOOR FAN HEAT ALREADY DEDUCTED AT 1250 BTUH/1000 CFM.

Multipliers for determining the performance with other indoor sections.

NOTE: For dry bulb temperatures different than those listed (between 73-87 F), sensible capacity increases by 1060 BTUH per 1000 CFM per degree above the listed temperature and decreases by 1060 BTUH per 1000 CFM per degree below the listed temperature.

NOTE: KW RATING IS FOR OUTDOOR AND INDOOR UNITS.

LOW CFM

Air Handler	Coil	T.C.	S.C.	KW
AV36C	-	1.00	1.00	1.01
MV12B	FC/MC/PC43B	1.00	0.99	1.03
MV12B	FC/MC/PC43C	1.00	0.99	1.03
MV16C	FC/MC/PC43C	1.00	1.00	1.03
MV12D	FC/MC/PC48D	1.00	0.99	1.00
MV12D	UC48D	1.00	0.99	1.00
MV16C	FC/MC/PC48C	1.01	1.01	1.01
MV16C	FC/MC/PC48D	1.01	1.01	1.01
MV16C	UC48D	1.01	1.01	1.01
MV20D	FC/MC/PC48D	1.00	1.00	1.01
MV20D	UC48D	1.00	1.00	1.01
MV12D	FC/MC62D	1.00	1.00	1.00
MV20D	FC/MC62D	1.01	1.01	1.01

Variable Speed Furnace	Coil	T.C.	S.C.	KW
(F,L)C8V*A12	FC/MC/PC37A	0.99	0.99	1.03
(F,L)C9V*A12	FC/MC/PC37A	1.00	0.99	1.04
(F,L)C8V*B16	FC/MC/PC43B	0.99	0.99	1.02
(F,L)C8V*B16	FC/MC/PC43C	0.99	0.99	1.02
(F,L)C8V*C16	FC/MC/PC43C	0.96	0.96	1.00
(F,L)C8V*C20	FC/MC/PC43C	1.00	1.00	1.02
(F,L)C9(C,V)*B12	FC/MC/PC43B	1.00	0.99	1.03
(F,L)C9(C,V)*B12	FC/MC/PC43C	1.00	0.99	1.03
(F,L)C9(C,V)*C16	FC/MC/PC43C	1.00	1.00	1.01
(F,L)C9(C,V)*C20	FC/MC/PC43C	1.00	1.00	1.03
(F,L)C8V*C16	FC/MC/PC48C	0.96	0.96	0.98
(F,L)C8V*C16	FC/MC/PC48D	0.96	0.96	0.98
(F,L)C8V*C16	UC48D	0.96	0.96	0.98
(F,L)C8V*C20	FC/MC/PC48C	1.01	1.01	1.00
(F,L)C8V*C20	FC/MC/PC48D	1.01	1.01	1.00
(F,L)C8V*C20	UC48D	1.01	1.01	1.00
(F,L)C9(C,V)*C16	FC/MC/PC48C	1.01	1.01	0.99
(F,L)C9(C,V)*C16	FC/MC/PC48D	1.01	1.01	0.99
(F,L)C9(C,V)*C16	UC48D	1.01	1.01	0.99
(F,L)C9(C,V)*C20	FC/MC/PC48C	1.01	1.01	1.02

Continued on Page 18.

Variable Speed Furnace	Coil	T.C.	S.C.	KW
(F,L)C9(C,V)*C20	FC/MC/PC48D	1.01	1.01	1.02
(F,L)C9(C,V)*C20	UC48D	1.01	1.01	1.02
(F,L)C9(C,V)*D20	FC/MC/PC48D	1.01	1.01	1.01
(F,L)C9(C,V)*D20	UC48D	1.01	1.01	1.01
(F,L)C8V*C20	FC/MC62D	1.01	1.01	1.01
(F,L)C9(C,V)*C20	FC/MC62D	1.01	1.01	1.02
(F,L)C9(C,V)*D20	FC/MC62D	1.01	1.01	1.02
(F,L)C8V*C16	HC42C	0.96	0.96	0.99
(F,L)C8V*C20	HC42C	1.00	1.00	1.01
(F,L)C9(C,V)*C16	HC42C	1.00	0.99	1.01
(F,L)C9(C,V)*C20	HC42C	1.00	1.00	1.03
C*(8,L)C*B12	FC/MC/PC35B	0.96	0.93	1.03
C*9C*B12	FC/MC/PC35B	0.98	0.97	1.05
C*(8,L)C*C16	FC/MC/PC35C	0.98	0.97	1.03
C*(8,L)C*C20	FC/MC/PC35C	1.01	1.07	1.07
C*9C*C16	FC/MC/PC35C	0.98	0.98	1.03
C*9C*C20	FC/MC/PC35C	0.96	0.94	1.03
C*(8,L)C*A12	FC/MC/PC36A	0.97	0.96	1.05
C*(8,L)C*B12	FC/MC/PC36B	0.96	0.93	1.02
C*9C*B12	FC/MC/PC36B	0.97	0.97	1.04
C*(8,L)C*C16	FC/MC/PC36C	0.98	0.97	1.02
C*(8,L)C*C20	FC/MC/PC36C	0.98	0.97	1.02
C*9C*C16	FC/MC/PC36C	0.99	1.02	1.05
C*9C*C20	FC/MC/PC36C	0.96	0.94	1.02
C*(8,L)C*A12	FC/MC/PC37A	0.95	0.89	1.02
C*(8,L)C*B12	FC/MC/PC42B	0.97	0.94	1.02
C*9C*B12	FC/MC/PC42B	0.98	0.98	1.04
C*(8,L)C*C16	FC/MC/PC42C	0.98	0.98	1.02
C*(8,L)C*C20	FC/MC/PC42C	0.97	0.95	1.01
C*9C*C16	FC/MC/PC42C	0.97	0.94	1.02
C*9C*C20	FC/MC/PC42C	0.97	0.95	1.02
C*(8,L)C*B12	FC/MC/PC43B	0.97	0.94	1.03
C*9C*B12	FC/MC/PC43B	0.98	0.98	1.04
C*(8,L)C*C16	FC/MC/PC43C	0.99	0.98	1.03
C*(8,L)C*C20	FC/MC/PC43C	0.97	0.95	1.01
C*9C*C16	FC/MC/PC43C	0.98	0.98	1.04
C*9C*C20	FC/MC/PC43C	0.97	0.94	1.02
C*(8,L)C*C16	FC/MC/PC48C	1.00	1.00	1.02
C*(8,L)C*C20	FC/MC/PC48C	0.97	0.94	1.01
C*9C*C16	FC/MC/PC48C	1.00	1.00	1.03
C*9C*C20	FC/MC/PC48C	0.97	0.95	1.02
C*(8,L)C*C16	HC42	0.98	0.98	1.03
C*(8,L)C*C20	HC42	0.97	0.95	1.01
C*9C*C16	HC42	0.98	0.98	1.04
C*9C*C20	HC42	0.98	0.98	1.02
C*(8,L)C*B12	HD48	0.97	0.95	1.02
C*(8,L)C*C16	HD48	0.99	0.99	1.02
C*(8,L)C*C20	HD48	0.97	0.93	1.01
C*9C*B12	HD48	0.96	0.92	1.02
C*9C*C16	HD48	0.99	0.98	1.02
C*9C*C20	HD48	0.97	0.94	1.02

Variable Speed Furnace	Coil	T.C.	S.C.	KW
C*(8,L)C*A12	UC36A	0.95	0.95	1.05
C*(8,L)C*B12	UC36B	0.94	0.91	1.02
C*9C*B12	UC36B	0.96	0.95	1.04
C*(8,L)C*C16	UC36C	0.96	0.95	1.02
C*(8,L)C*C20	UC36C	0.96	0.95	1.02
C*9C*C16	UC36C	0.98	1.00	1.05
C*9C*C20	UC36C	0.95	0.92	1.02
C*(8,L)C*B12	UC42B	0.96	0.94	1.02
C*9C*B12	UC42B	0.97	0.96	1.04
C*(8,L)C*C16	UC42C	0.97	0.97	1.02
C*(8,L)C*C20	UC42C	0.96	0.94	1.01
C*9C*C16	UC42C	0.96	0.93	1.02
C*9C*C20	UC42C	0.96	0.94	1.02
C*(8,L)C*C16	UC48C	0.98	0.99	1.02
C*(8,L)C*C20	UC48C	0.95	0.93	1.01
C*9C*C16	UC48C	0.98	0.99	1.03
C*9C*C20	UC48C	0.97	0.95	1.03
G*9V*B12	FC/MC/PC35B	0.98	0.97	1.05
G*9V*C16	FC/MC/PC35C	0.98	0.98	1.03
G*9V*C20	FC/MC/PC35C	0.96	0.94	1.03
G*9V*A12	FC/MC/PC36A	0.96	0.94	1.05
G*9V*B12	FC/MC/PC36B	0.97	0.97	1.04
G*9V*C16	FC/MC/PC36C	0.99	1.02	1.05
G*9V*C20	FC/MC/PC36C	0.96	0.94	1.02
G*9V*A12	FC/MC/PC37A	0.98	0.97	1.06
G*9V*B12	FC/MC/PC42B	0.98	0.98	1.04
G*9V*C16	FC/MC/PC42C	0.97	0.94	1.02
G*9V*C20	FC/MC/PC42C	0.97	0.95	1.02
G*9V*B12	FC/MC/PC43B	0.98	0.98	1.04
G*9V*C16	FC/MC/PC43C	0.98	0.98	1.04
G*9V*C20	FC/MC/PC43C	0.97	0.94	1.02
G*9V*C16	FC/MC/PC48C	1.00	1.00	1.03
G*9V*C20	FC/MC/PC48C	0.97	0.95	1.02
G*9V*C16	HC42	0.98	0.98	1.04
G*9V*C20	HC42	0.98	0.98	1.02
G*9V*B12	HD48	0.96	0.92	1.02
G*9V*C16	HD48	0.99	0.98	1.02
G*9V*C20	HD48	0.97	0.94	1.02
G*9V*A12	UC36A	0.94	0.92	1.05
G*9V*B12	UC36B	0.96	0.95	1.04
G*9V*C16	UC36C	0.98	1.00	1.05
G*9V*C20	UC36C	0.95	0.92	1.02
G*9V*B12	UC42B	0.97	0.96	1.04
G*9V*C16	UC42C	0.96	0.93	1.02
G*9V*C20	UC42C	0.96	0.94	1.02
G*9V*C16	UC48C	0.98	0.99	1.03
G*9V*C20	UC48C	0.97	0.95	1.03

COOLING PERFORMANCE DATA - HIGH CFM 2-STAGE OPERATION																
OUTDOOR UNIT MODEL NO.		AC8B036F1														
INDOOR COIL MODEL NO.		FC62D + MV12D														
CONDENSER ENTERING AIR TEMPERATURE	ID CFM	1100					1200					1300				
	ID DB (°F)	80	80	75	80	80	80	80	75	80	80	80	80	75	80	80
	ID WB (°F)	57	62	62	67	72	57	62	62	67	72	57	62	62	67	72
65	T.C.	35.7	38.1	38.5	41.2	45.8	37.2	39.1	38.8	41.7	46.1	38.6	40.1	39.1	42.1	46.3
	S.C.	34.5	31.9	27.3	26.9	21.2	36.1	33.4	28.6	27.7	22.1	37.5	35.0	29.9	28.4	22.9
	K.W.	1.71	1.74	1.74	1.79	1.82	1.74	1.76	1.76	1.81	1.84	1.78	1.79	1.78	1.84	1.86
75	T.C.	34.6	36.5	36.7	39.5	43.6	35.9	37.4	37.1	40.0	43.9	37.1	38.2	37.5	40.4	44.2
	S.C.	33.6	31.1	26.5	26.0	20.6	34.8	32.6	27.6	27.0	21.4	36.0	34.1	28.8	27.9	22.1
	K.W.	1.98	2.00	2.00	2.05	2.07	2.00	2.02	2.01	2.06	2.09	2.04	2.05	2.04	2.09	2.12
85	T.C.	33.6	35.0	35.0	37.8	41.5	34.6	35.7	35.4	38.3	41.8	35.5	36.4	35.9	38.7	42.0
	S.C.	32.6	30.3	25.6	25.2	20.0	33.6	31.8	26.6	26.3	20.6	34.5	33.3	27.7	27.4	21.2
	K.W.	2.24	2.26	2.25	2.30	2.33	2.26	2.28	2.27	2.32	2.35	2.30	2.30	2.30	2.34	2.38
95	T.C.	32.5	33.4	33.2	36.1	39.4	33.3	34.0	33.7	36.6	39.6	34.0	34.5	34.2	37.1	39.8
	S.C.	31.6	29.4	24.7	24.3	19.4	32.3	31.0	25.6	25.6	19.9	33.0	32.4	26.6	26.9	20.3
	K.W.	2.50	2.52	2.51	2.55	2.59	2.52	2.53	2.53	2.57	2.60	2.56	2.56	2.56	2.59	2.63
105	T.C.	30.7	31.5	31.2	33.7	37.0	31.5	32.0	31.6	34.2	37.2	32.1	32.6	32.0	34.7	37.4
	S.C.	29.9	28.4	23.7	23.6	18.6	30.6	29.6	24.7	24.8	19.0	31.3	30.6	25.7	25.9	19.4
	K.W.	2.89	2.90	2.90	2.94	2.97	2.92	2.92	2.91	2.96	2.99	2.95	2.95	2.94	2.98	3.02
115	T.C.	29.0	29.6	29.2	31.3	34.7	29.7	30.2	29.5	31.8	34.9	30.4	30.7	29.8	32.3	35.0
	S.C.	28.3	27.5	22.8	22.9	17.9	29.0	28.2	23.8	23.9	18.2	29.6	28.9	24.8	24.9	18.5
	K.W.	3.28	3.28	3.27	3.32	3.35	3.30	3.29	3.29	3.33	3.37	3.33	3.32	3.31	3.35	3.40
125	T.C.	27.3	27.7	27.2	29.0	32.4	28.0	28.3	27.4	29.5	32.6	28.6	28.8	27.7	30.0	32.7
	S.C.	26.7	26.5	21.9	22.2	17.2	27.3	26.8	22.9	23.1	17.4	28.0	27.1	24.0	24.0	17.6
	K.W.	3.66	3.65	3.65	3.70	3.73	3.68	3.67	3.66	3.71	3.75	3.71	3.70	3.69	3.73	3.78

NOTE: ALL CAPACITIES ARE NET (KBTUH) WITH INDOOR FAN HEAT ALREADY DEDUCTED AT 1250 BTUH/1000 CFM.

Multipliers for determining the performance with other indoor sections.

NOTE: For dry bulb temperatures different than those listed (between 73-87 F), sensible capacity increases by 1060 BTUH per 1000 CFM per degree above the listed temperature and decreases by 1060 BTUH per 1000 CFM per degree below the listed temperature.

NOTE: KW RATING IS FOR OUTDOOR AND INDOOR UNITS.

HIGH CFM

Air Handler	Coil	T.C.	S.C.	KW
AV36C	-	0.97	0.97	1.03
MV12B	FC/MC/PC43B	0.98	0.98	1.03
MV12B	FC/MC/PC43C	0.98	0.98	1.03
MV16C	FC/MC/PC43C	0.99	0.99	1.01
MV12D	FC/MC/PC48D	0.98	0.98	1.00
MV12D	UC48D	0.98	0.98	1.00
MV16C	FC/MC/PC48C	0.99	0.99	1.00
MV16C	FC/MC/PC48D	0.99	0.99	1.00
MV16C	UC48D	0.99	0.99	1.00
MV20D	FC/MC/PC48D	1.00	1.00	1.00
MV20D	UC48D	1.00	1.00	1.00
MV12D	FC/MC62D	1.00	1.00	1.00
MV20D	FC/MC62D	1.01	1.01	1.00

Variable Speed Furnace	Coil	T.C.	S.C.	KW
(F,L)C8V*A12	FC/MC/PC37A	0.98	0.98	1.05
(F,L)C9V*A12	FC/MC/PC37A	0.97	0.97	1.07
(F,L)C8V*B16	FC/MC/PC43B	0.98	0.98	1.02
(F,L)C8V*B16	FC/MC/PC43C	0.98	0.98	1.02
(F,L)C8V*C16	FC/MC/PC43C	0.99	0.99	1.02
(F,L)C8V*C20	FC/MC/PC43C	0.98	0.98	1.04
(F,L)C9(C,V)*B12	FC/MC/PC43B	0.97	0.97	1.05
(F,L)C9(C,V)*B12	FC/MC/PC43C	0.97	0.97	1.05
(F,L)C9(C,V)*C16	FC/MC/PC43C	0.98	0.98	1.02
(F,L)C9(C,V)*C20	FC/MC/PC43C	0.98	0.98	1.03
(F,L)C8V*C16	FC/MC/PC48C	0.99	0.99	1.01
(F,L)C8V*C16	FC/MC/PC48D	0.99	0.99	1.01
(F,L)C8V*C16	UC48D	0.99	0.99	1.01
(F,L)C8V*C20	FC/MC/PC48C	0.99	0.99	1.04
(F,L)C8V*C20	FC/MC/PC48D	0.99	0.99	1.04
(F,L)C8V*C20	UC48D	0.99	0.99	1.04
(F,L)C9(C,V)*C16	FC/MC/PC48C	0.99	0.99	1.02
(F,L)C9(C,V)*C16	FC/MC/PC48D	0.99	0.99	1.02
(F,L)C9(C,V)*C16	UC48D	0.99	0.99	1.02
(F,L)C9(C,V)*C20	FC/MC/PC48C	0.99	0.99	1.03

Continued on Page 20.

Variable Speed Furnace	Coil	T.C.	S.C.	KW
(F,L)C9(C,V)*C20	FC/MC/PC48D	0.99	0.99	1.03
(F,L)C9(C,V)*C20	UC48D	0.99	0.99	1.03
(F,L)C9(C,V)*D20	FC/MC/PC48D	0.99	0.99	1.02
(F,L)C9(C,V)*D20	UC48D	0.99	0.99	1.02
(F,L)C8V*C20	FC/MC62D	1.00	1.00	1.04
(F,L)C9(C,V)*C20	FC/MC62D	1.00	1.00	1.03
(F,L)C9(C,V)*D20	FC/MC62D	1.01	1.00	1.02
(F,L)C8V*C16	HC42C	0.99	0.99	1.02
(F,L)C8V*C20	HC42C	0.98	0.98	1.04
(F,L)C9(C,V)*C16	HC42C	0.98	0.98	1.02
(F,L)C9(C,V)*C20	HC42C	0.98	0.98	1.03
C*(8,L)C*B12	FC/MC/PC35B	0.97	0.96	1.07
C*9C*B12	FC/MC/PC35B	0.97	0.97	1.07
C*(8,L)C*C16	FC/MC/PC35C	0.98	0.97	1.04
C*(8,L)C*C20	FC/MC/PC35C	0.97	0.96	1.02
C*9C*C16	FC/MC/PC35C	0.98	0.97	1.04
C*9C*C20	FC/MC/PC35C	0.98	1.00	1.07
C*(8,L)C*A12	FC/MC/PC36A	0.95	0.94	1.07
C*(8,L)C*B12	FC/MC/PC36B	0.96	0.96	1.05
C*9C*B12	FC/MC/PC36B	0.96	0.94	1.05
C*(8,L)C*C16	FC/MC/PC36C	0.96	0.95	1.03
C*(8,L)C*C20	FC/MC/PC36C	0.96	0.95	1.02
C*9C*C16	FC/MC/PC36C	0.96	0.95	1.03
C*9C*C20	FC/MC/PC36C	0.97	0.99	1.06
C*(8,L)C*A12	FC/MC/PC37A	0.95	0.90	1.03
C*(8,L)C*B12	FC/MC/PC42B	0.96	0.95	1.03
C*9C*B12	FC/MC/PC42B	0.96	0.96	1.07
C*(8,L)C*C16	FC/MC/PC42C	0.98	0.98	1.01
C*(8,L)C*C20	FC/MC/PC42C	0.97	0.96	1.00
C*9C*C16	FC/MC/PC42C	0.96	0.96	1.03
C*9C*C20	FC/MC/PC42C	0.98	1.01	1.05
C*(8,L)C*B12	FC/MC/PC43B	0.98	0.98	1.07
C*9C*B12	FC/MC/PC43B	0.98	0.98	1.07
C*(8,L)C*C16	FC/MC/PC43C	0.98	0.99	1.03
C*(8,L)C*C20	FC/MC/PC43C	0.98	0.99	1.02
C*9C*C16	FC/MC/PC43C	0.98	0.99	1.06
C*9C*C20	FC/MC/PC43C	0.98	0.99	1.03
C*(8,L)C*C16	FC/MC/PC48C	0.98	0.99	1.02
C*(8,L)C*C20	FC/MC/PC48C	0.98	0.98	1.01
C*9C*C16	FC/MC/PC48C	0.98	0.99	1.04
C*9C*C20	FC/MC/PC48C	0.98	1.02	1.06
C*(8,L)C*C16	HC42	0.98	0.98	1.03
C*(8,L)C*C20	HC42	0.98	0.98	1.02
C*9C*C16	HC42	0.98	0.98	1.06
C*9C*C20	HC42	0.98	0.98	1.04
C*(8,L)C*B12	HD48	0.98	0.98	1.05
C*(8,L)C*C16	HD48	0.98	0.98	1.02
C*(8,L)C*C20	HD48	0.98	0.97	1.01
C*9C*B12	HD48	0.98	0.96	1.06
C*9C*C16	HD48	0.98	0.98	1.03

Variable Speed Furnace	Coil	T.C.	S.C.	KW
C*9C*C20	HD48	0.98	1.01	1.06
C*(8,L)C*A12	UC36A	0.94	0.92	1.07
C*(8,L)C*B12	UC36B	0.95	0.94	1.05
C*9C*B12	UC36B	0.95	0.93	1.04
C*(8,L)C*C16	UC36C	0.95	0.93	1.03
C*(8,L)C*C20	UC36C	0.95	0.93	1.02
C*9C*C16	UC36C	0.95	0.93	1.03
C*9C*C20	UC36C	0.96	0.98	1.06
C*(8,L)C*B12	UC42B	0.96	0.95	1.03
C*9C*B12	UC42B	0.95	0.95	1.07
C*(8,L)C*C16	UC42C	0.97	0.96	1.01
C*(8,L)C*C20	UC42C	0.97	0.95	1.00
C*9C*C16	UC42C	0.96	0.95	1.03
C*9C*C20	UC42C	0.98	0.99	1.05
C*(8,L)C*C16	UC48C	0.98	0.99	1.02
C*(8,L)C*C20	UC48C	0.98	0.98	1.01
C*9C*C16	UC48C	0.98	0.99	1.03
C*9C*C20	UC48C	0.98	1.02	1.06
G*9V*B12	FC/MC/PC35B	0.97	0.97	1.07
G*9V*C16	FC/MC/PC35C	0.98	0.97	1.04
G*9V*C20	FC/MC/PC35C	0.98	1.00	1.07
G*9V*A12	FC/MC/PC36A	0.95	0.94	1.08
G*9V*B12	FC/MC/PC36B	0.96	0.94	1.05
G*9V*C16	FC/MC/PC36C	0.96	0.95	1.03
G*9V*C20	FC/MC/PC36C	0.97	0.99	1.06
G*9V*A12	FC/MC/PC37A	0.96	0.94	1.06
G*9V*B12	FC/MC/PC42B	0.96	0.96	1.07
G*9V*C16	FC/MC/PC42C	0.96	0.96	1.03
G*9V*C20	FC/MC/PC42C	0.98	1.01	1.05
G*9V*B12	FC/MC/PC43B	0.98	0.98	1.07
G*9V*C16	FC/MC/PC43C	0.98	0.99	1.06
G*9V*C20	FC/MC/PC43C	0.98	0.99	1.03
G*9V*C16	FC/MC/PC48C	0.98	0.99	1.04
G*9V*C20	FC/MC/PC48C	0.98	1.02	1.06
G*9V*C16	HC42	0.98	0.98	1.06
G*9V*C20	HC42	0.98	0.98	1.04
G*9V*B12	HD48	0.98	0.96	1.06
G*9V*C16	HD48	0.98	0.98	1.03
G*9V*C20	HD48	0.98	1.01	1.06
G*9V*A12	UC36A	0.94	0.93	1.07
G*9V*B12	UC36B	0.95	0.93	1.04
G*9V*C16	UC36C	0.95	0.93	1.03
G*9V*C20	UC36C	0.96	0.98	1.06
G*9V*B12	UC42B	0.95	0.95	1.07
G*9V*C16	UC42C	0.96	0.95	1.03
G*9V*C20	UC42C	0.98	0.99	1.05
G*9V*C16	UC48C	0.98	0.99	1.03
G*9V*C20	UC48C	0.98	1.02	1.06

COOLING PERFORMANCE DATA - LOW CFM 1-STAGE OPERATION																
OUTDOOR UNIT MODEL NO.		AC8B048F1														
INDOOR COIL MODEL NO.		FC62D + MV20D														
CONDENSER ENTERING AIR TEMPERATURE	ID CFM	950					1000					1050				
	ID DB (°F)	80	80	75	80	80	80	80	75	80	80	80	80	75	80	80
	ID WB (°F)	57	62	62	67	72	57	62	62	67	72	57	62	62	67	72
65	T.C.	35.4	36.6	36.2	39.8	42.3	36.1	37.2	36.8	40.2	42.9	36.8	37.8	37.4	40.6	43.4
	S.C.	34.3	31.8	26.9	27.2	21.7	34.8	32.5	27.6	27.8	22.0	35.3	33.3	28.2	28.5	22.3
	K.W.	1.50	1.50	1.49	1.48	1.48	1.50	1.49	1.49	1.48	1.47	1.49	1.49	1.49	1.47	1.47
75	T.C.	34.0	34.9	34.5	37.8	40.4	34.6	35.4	35.0	38.2	40.9	35.2	36.0	35.5	38.6	41.5
	S.C.	32.9	31.0	26.2	26.4	21.0	33.4	31.7	26.8	27.0	21.3	33.9	32.4	27.4	27.6	21.7
	K.W.	1.81	1.81	1.81	1.80	1.79	1.81	1.81	1.80	1.79	1.78	1.80	1.80	1.80	1.79	1.78
85	T.C.	32.5	33.1	32.8	35.7	38.5	33.1	33.7	33.2	36.2	39.0	33.7	34.2	33.6	36.6	39.5
	S.C.	31.5	30.2	25.5	25.5	20.3	32.0	30.9	26.0	26.1	20.7	32.5	31.6	26.6	26.7	21.1
	K.W.	2.12	2.12	2.12	2.11	2.10	2.12	2.12	2.12	2.11	2.10	2.12	2.12	2.11	2.11	2.09
95	T.C.	31.1	31.4	31.1	33.7	36.6	31.7	31.9	31.4	34.2	37.1	32.2	32.4	31.7	34.6	37.6
	S.C.	30.1	29.4	24.8	24.7	19.6	30.6	30.1	25.3	25.3	20.0	31.1	30.8	25.8	25.8	20.4
	K.W.	2.44	2.44	2.44	2.43	2.41	2.43	2.43	2.43	2.43	2.41	2.43	2.43	2.43	2.42	2.40
105	T.C.	29.4	29.7	28.9	31.5	34.2	30.0	30.2	29.3	31.9	34.6	30.5	30.7	29.6	32.3	35.0
	S.C.	28.5	27.8	23.8	23.8	18.7	28.9	28.5	24.3	24.4	19.1	29.4	29.1	24.8	24.9	19.6
	K.W.	2.86	2.87	2.87	2.87	2.84	2.86	2.86	2.86	2.86	2.84	2.86	2.86	2.86	2.85	2.84
115	T.C.	27.8	28.0	26.9	29.3	31.9	28.4	28.6	27.2	29.7	32.2	28.9	29.1	27.6	30.1	32.5
	S.C.	26.9	26.3	22.9	23.0	17.8	27.4	26.9	23.4	23.5	18.3	27.8	27.5	23.9	24.1	18.7
	K.W.	3.28	3.28	3.29	3.29	3.26	3.27	3.28	3.28	3.27	3.26	3.27	3.27	3.28	3.27	3.26
125	T.C.	26.2	26.4	24.8	27.1	29.6	26.7	26.9	25.2	27.5	29.8	27.2	27.5	25.6	27.9	30.0
	S.C.	25.4	24.8	21.9	22.1	16.9	25.8	25.4	22.4	22.7	17.4	26.2	26.0	22.9	23.3	17.9
	K.W.	3.69	3.70	3.71	3.71	3.67	3.69	3.69	3.70	3.69	3.67	3.69	3.69	3.70	3.68	3.68

NOTE: ALL CAPACITIES ARE NET (KBTUH) WITH INDOOR FAN HEAT ALREADY DEDUCTED AT 1250 BTUH/1000 CFM.

Multipliers for determining the performance with other indoor sections.

NOTE: For dry bulb temperatures different than those listed (between 73-87 F), sensible capacity increases by 1060 BTUH per 1000 CFM per degree above the listed temperature and decreases by 1060 BTUH per 1000 CFM per degree below the listed temperature.

NOTE: KW RATING IS FOR OUTDOOR AND INDOOR UNITS.

LOW CFM

Air Handler	Coil	T.C.	S.C.	KW
AV/SV48D	–	0.97	0.97	1.00
AV/SV60D	–	0.97	0.97	1.00
F4FV060	–	0.99	0.98	1.01
MV16C	FC/MC/PC48C	1.00	1.00	0.99
MV16C	FC/MC/PC48D	1.00	1.00	0.99
MV16C	UC48D	1.00	1.00	0.99
MV20D	FC/MC/PC48D	1.00	1.00	1.00
MV20D	UC48D	1.00	1.00	1.00
MV20D	FC/MC62D	1.00	1.00	1.00

Continued on Page 22.

Variable Speed Furnace	Coil	T.C.	S.C.	KW
(F,L)C8V*C16	FC/MC/PC48C	0.97	0.97	0.98
(F,L)C8V*C16	FC/MC/PC48D	0.97	0.97	0.98
(F,L)C8V*C16	UC48D	0.97	0.97	0.98
(F,L)C8V*C20	FC/MC/PC48C	1.00	1.00	0.99
(F,L)C8V*C20	FC/MC/PC48D	1.00	1.00	0.99
(F,L)C8V*C20	UC48D	1.00	1.00	0.99
(F,L)C9(C,V)*C16	FC/MC/PC48C	1.01	1.02	0.98
(F,L)C9(C,V)*C16	FC/MC/PC48D	1.01	1.02	0.98
(F,L)C9(C,V)*C16	UC48D	1.01	1.02	0.98
(F,L)C9(C,V)*C20	FC/MC/PC48C	0.99	0.99	1.00
(F,L)C9(C,V)*C20	FC/MC/PC48D	0.99	0.99	1.00
(F,L)C9(C,V)*C20	UC48D	0.99	0.99	1.00
(F,L)C9(C,V)*D20	FC/MC/PC48D	0.99	0.99	1.00
(F,L)C9(C,V)*D20	UC48D	0.99	0.99	1.00
(F,L)C8V*C20	FC/MC62D	1.00	1.00	0.99
(F,L)C9(C,V)*C20	FC/MC62D	1.00	1.00	1.00
(F,L)C9(C,V)*D20	FC/MC62D	0.99	0.99	1.00
(F,L)C9(C,V)*D20	HC60D	0.95	0.95	1.00
C*(8,L)C*C16	FC/MC/PC48C	1.00	0.99	1.02
C*(8,L)C*C20	FC/MC/PC48C	1.00	0.99	1.02
C*9C*C16	FC/MC/PC48C	1.00	1.00	1.02
C*9C*C20	FC/MC/PC48C	1.00	1.00	1.02
C*9C*D20	FC/MC/PC48D	0.99	0.98	1.02
C*9C*D20	FC/MC/PC60D	0.97	0.96	1.02
C*9C*D20	FC/MC62D	0.99	0.99	1.02
C*(8,L)C*C16	FC/PC60C	0.98	0.97	1.01
C*(8,L)C*C20	FC/PC60C	0.98	0.97	1.01
C*9C*C16	FC/PC60C	0.97	0.96	1.02
C*9C*C20	FC/PC60C	0.98	0.97	1.02
C*9C*D20	HC60	0.96	0.96	1.03
C*(8,L)C*C16	HD48	0.98	0.97	1.02
C*(8,L)C*C20	HD48	0.98	0.97	1.02
C*9C*C16	HD48	0.99	0.97	1.02
C*9C*C20	HD48	0.99	0.97	1.02
C*9C*D20	HD48	0.98	0.97	1.02

Variable Speed Furnace	Coil	T.C.	S.C.	KW
C*(8,L)C*C16	HD60	1.01	1.00	1.01
C*(8,L)C*C20	HD60	1.01	1.00	1.00
C*9C*C16	HD60	1.00	1.00	1.02
C*9C*C20	HD60	1.01	1.00	1.02
C*9C*D20	HD60	1.00	1.00	1.02
C*(8,L)C*C16	UC48C	0.95	0.95	1.02
C*(8,L)C*C20	UC48C	0.95	0.95	1.03
C*9C*C16	UC48C	0.95	0.96	1.03
C*9C*C20	UC48C	0.95	0.97	1.02
C*9C*D20	UC48D	0.89	0.90	1.03
C*(8,L)C*C16	UC60C	0.90	0.87	1.02
C*(8,L)C*C20	UC60C	0.90	0.87	1.01
C*9C*C16	UC60C	0.90	0.87	1.03
C*9C*C20	UC60C	0.90	0.87	1.03
C*9C*D20	UC60D	0.90	0.87	1.03
G*9V*C16	FC/MC/PC48C	1.00	1.00	1.02
G*9V*C20	FC/MC/PC48C	1.00	1.00	1.02
G*9V*D20	FC/MC/PC48D	0.99	0.98	1.02
G*9V*D20	FC/MC/PC60D	0.97	0.96	1.02
G*9V*D20	FC/MC62D	0.99	0.99	1.02
G*9V*C16	FC/PC60C	0.97	0.96	1.02
G*9V*C20	FC/PC60C	0.98	0.97	1.02
G*9V*D20	HC60	0.96	0.96	1.03
G*9V*C16	HD48	0.99	0.97	1.02
G*9V*C20	HD48	0.99	0.97	1.02
G*9V*D20	HD48	0.98	0.97	1.02
G*9V*C16	HD60	1.00	1.00	1.02
G*9V*C20	HD60	1.01	1.00	1.02
G*9V*D20	HD60	1.00	1.00	1.02
G*9V*C16	UC48C	0.95	0.96	1.03
G*9V*C20	UC48C	0.95	0.97	1.02
G*9V*D20	UC48D	0.89	0.90	1.03
G*9V*C16	UC60C	0.90	0.87	1.03
G*9V*C20	UC60C	0.90	0.87	1.03
G*9V*D20	UC60D	0.90	0.87	1.03

COOLING PERFORMANCE DATA - HIGH CFM 2-STAGE OPERATION																
OUTDOOR UNIT MODEL NO.		AC8B048F1														
INDOOR COIL MODEL NO.		FC62D + MV20D														
CONDENSER ENTERING AIR TEMPERATURE	ID CFM	1500					1600					1700				
	ID DB (°F)	80	80	75	80	80	80	80	75	80	80	80	80	75	80	80
	ID WB (°F)	57	62	62	67	72	57	62	62	67	72	57	62	62	67	72
65	T.C.	48.7	49.9	49.0	53.2	56.4	49.6	50.4	49.5	54.4	56.8	50.5	50.9	50.0	55.5	57.2
	S.C.	48.0	44.9	38.2	37.9	29.7	48.9	46.3	39.1	39.0	30.3	49.7	47.6	40.0	40.1	30.9
	K.W.	2.53	2.57	2.56	2.64	2.71	2.58	2.61	2.61	2.67	2.75	2.64	2.67	2.66	2.72	2.79
75	T.C.	46.8	47.7	46.8	50.9	53.6	47.6	48.2	47.2	51.8	54.0	48.3	48.8	47.6	52.5	54.4
	S.C.	46.2	43.8	37.1	36.8	28.7	46.9	45.0	38.0	37.9	29.3	47.6	46.2	38.9	38.9	29.9
	K.W.	2.89	2.91	2.90	2.98	3.05	2.93	2.96	2.95	3.02	3.09	2.99	3.01	3.00	3.07	3.15
85	T.C.	45.0	45.5	44.5	48.6	50.9	45.6	46.1	44.9	49.1	51.3	46.2	46.6	45.2	49.6	51.6
	S.C.	44.3	42.6	35.9	35.7	27.8	44.9	43.7	36.9	36.7	28.4	45.6	44.8	37.8	37.7	28.9
	K.W.	3.24	3.26	3.25	3.33	3.40	3.29	3.31	3.29	3.37	3.44	3.34	3.36	3.34	3.42	3.50
95	T.C.	43.1	43.4	42.2	46.3	48.2	43.5	43.9	42.5	46.5	48.5	44.0	44.4	42.9	46.6	48.8
	S.C.	42.4	41.5	34.8	34.6	26.9	43.0	42.4	35.7	35.6	27.4	43.5	43.3	36.7	36.5	27.9
	K.W.	3.59	3.61	3.60	3.68	3.75	3.64	3.66	3.64	3.72	3.79	3.69	3.71	3.69	3.77	3.85
105	T.C.	40.7	41.0	39.6	43.5	45.2	41.2	41.5	39.9	43.7	45.4	41.6	41.9	40.1	43.9	45.6
	S.C.	40.1	39.3	33.5	33.5	25.8	40.6	40.1	34.4	34.4	26.3	41.1	40.8	35.4	35.3	26.8
	K.W.	4.10	4.12	4.10	4.18	4.25	4.15	4.16	4.14	4.22	4.29	4.21	4.22	4.19	4.27	4.35
115	T.C.	38.5	38.7	37.2	40.7	42.4	38.9	39.1	37.3	40.9	42.5	39.3	39.5	37.4	41.2	42.5
	S.C.	37.9	37.2	32.3	32.4	24.9	38.4	37.8	33.2	33.3	25.3	38.8	38.4	34.1	34.2	25.7
	K.W.	4.60	4.60	4.58	4.67	4.74	4.65	4.65	4.62	4.71	4.78	4.70	4.71	4.67	4.76	4.83
125	T.C.	36.2	36.4	34.7	37.9	39.6	36.6	36.8	34.7	38.2	39.6	36.9	37.1	34.7	38.4	39.5
	S.C.	35.7	35.1	31.1	31.3	23.9	36.1	35.6	32.0	32.2	24.3	36.5	36.0	32.8	33.1	24.6
	K.W.	5.09	5.09	5.07	5.16	5.23	5.14	5.14	5.11	5.20	5.27	5.20	5.21	5.16	5.25	5.32

NOTE: ALL CAPACITIES ARE NET (KBTUH) WITH INDOOR FAN HEAT ALREADY DEDUCTED AT 1250 BTUH/1000 CFM.

Multipliers for determining the performance with other indoor sections

NOTE: For dry bulb temperatures different than those listed (between 73-87 F), sensible capacity increases by 1060 BTUH per 1000 CFM per degree above the listed temperature and decreases by 1060 BTUH per 1000 CFM per degree below the listed temperature.

NOTE: KW RATING IS FOR OUTDOOR AND INDOOR UNITS.

HIGH CFM

Air Handler	Coil	T.C.	S.C.	KW
AV/SV48D	–	0.96	0.96	0.99
AV/SV60D	–	0.96	0.96	0.99
F4FV060	–	0.96	0.96	0.98
MV16C	FC/MC/PC48C	0.99	0.99	0.99
MV16C	FC/MC/PC48D	0.99	0.99	0.99
MV16C	UC48D	0.99	0.99	0.99
MV20D	FC/MC/PC48D	0.99	0.99	1.00
MV20D	UC48D	0.99	0.99	1.00
MV20D	FC/MC62D	1.00	1.00	1.00

Continued on Page 24.

Variable Speed Furnace	Coil	T.C.	S.C.	KW
(F,L)C8V*C16	FC/MC/PC48C	0.97	0.97	1.01
(F,L)C8V*C16	FC/MC/PC48D	0.97	0.97	1.01
(F,L)C8V*C16	UC48D	0.97	0.97	1.01
(F,L)C8V*C20	FC/MC/PC48C	0.98	0.98	1.02
(F,L)C8V*C20	FC/MC/PC48D	0.98	0.98	1.02
(F,L)C8V*C20	UC48D	0.98	0.98	1.02
(F,L)C9(C,V)*C16	FC/MC/PC48C	0.98	0.98	1.03
(F,L)C9(C,V)*C16	FC/MC/PC48D	0.98	0.98	1.03
(F,L)C9(C,V)*C16	UC48D	0.98	0.98	1.03
(F,L)C9(C,V)*C20	FC/MC/PC48C	0.98	0.98	1.02
(F,L)C9(C,V)*C20	FC/MC/PC48D	0.98	0.98	1.02
(F,L)C9(C,V)*C20	UC48D	0.98	0.98	1.02
(F,L)C9(C,V)*D20	FC/MC/PC48D	0.98	0.98	1.00
(F,L)C9(C,V)*D20	UC48D	0.98	0.98	1.00
(F,L)C8V*C20	FC/MC62D	0.99	0.99	1.01
(F,L)C9(C,V)*C20	FC/MC62D	0.99	0.99	1.02
(F,L)C9(C,V)*D20	FC/MC62D	0.99	0.99	1.01
(F,L)C9(C,V)*D20	HC60D	0.95	0.95	1.00
C*(8,L)C*C16	FC/MC/PC48C	1.00	1.00	1.04
C*(8,L)C*C20	FC/MC/PC48C	1.00	1.00	1.04
C*9C*C16	FC/MC/PC48C	1.00	0.99	1.04
C*9C*C20	FC/MC/PC48C	1.00	0.99	1.04
C*9C*D20	FC/MC/PC48D	0.99	0.98	1.04
C*9C*D20	FC/MC/PC60D	0.98	0.98	1.03
C*9C*D20	FC/MC62D	0.99	0.98	1.03
C*(8,L)C*C16	FC/PC60C	0.98	0.98	1.03
C*(8,L)C*C20	FC/PC60C	0.99	0.98	1.01
C*9C*C16	FC/PC60C	0.98	0.98	1.04
C*9C*C20	FC/PC60C	0.98	0.98	1.04
C*9C*D20	HC60	0.97	0.97	1.03
C*(8,L)C*C16	HD48	1.00	0.98	1.03
C*(8,L)C*C20	HD48	1.00	0.98	1.04
C*9C*C16	HD48	0.99	0.97	1.04
C*9C*C20	HD48	0.99	0.97	1.04
C*9C*D20	HD48	1.00	0.97	1.04

Variable Speed Furnace	Coil	T.C.	S.C.	KW
C*(8,L)C*C16	HD60	1.00	1.00	1.03
C*(8,L)C*C20	HD60	1.00	1.01	1.01
C*9C*C16	HD60	1.00	1.00	1.04
C*9C*C20	HD60	1.00	1.00	1.04
C*9C*D20	HD60	1.00	1.00	1.04
C*(8,L)C*C16	UC48C	0.97	0.97	1.03
C*(8,L)C*C20	UC48C	0.96	0.96	1.03
C*9C*C16	UC48C	0.96	0.96	1.03
C*9C*C20	UC48C	0.96	0.96	1.04
C*9C*D20	UC48D	0.92	0.90	1.03
C*(8,L)C*C16	UC60C	0.93	0.90	1.02
C*(8,L)C*C20	UC60C	0.93	0.91	1.00
C*9C*C16	UC60C	0.92	0.90	1.03
C*9C*C20	UC60C	0.92	0.90	1.03
C*9C*D20	UC60D	0.93	0.90	1.02
G*9V*C16	FC/MC/PC48C	1.00	0.99	1.04
G*9V*C20	FC/MC/PC48C	1.00	0.99	1.04
G*9V*D20	FC/MC/PC48D	0.99	0.98	1.04
G*9V*D20	FC/MC/PC60D	0.98	0.98	1.03
G*9V*D20	FC/MC62D	0.99	0.98	1.03
G*9V*C16	FC/PC60C	0.98	0.98	1.04
G*9V*C20	FC/PC60C	0.98	0.98	1.04
G*9V*D20	HC60	0.97	0.97	1.03
G*9V*C16	HD48	0.99	0.97	1.04
G*9V*C20	HD48	0.99	0.97	1.04
G*9V*D20	HD48	1.00	0.97	1.04
G*9V*C16	HD60	1.00	1.00	1.04
G*9V*C20	HD60	1.00	1.00	1.04
G*9V*D20	HD60	1.00	1.00	1.04
G*9V*C16	UC48C	0.96	0.96	1.03
G*9V*C20	UC48C	0.96	0.96	1.04
G*9V*D20	UC48D	0.92	0.90	1.03
G*9V*C16	UC60C	0.92	0.90	1.03
G*9V*C20	UC60C	0.92	0.90	1.03
G*9V*D20	UC60D	0.93	0.90	1.02

COOLING PERFORMANCE DATA - LOW CFM 1-STAGE OPERATION																
OUTDOOR UNIT MODEL NO.		AC8B060F1														
INDOOR COIL MODEL NO.		FC62D + MV20D														
CONDENSER ENTERING AIR TEMPERATURE	ID CFM	1100					1150					1200				
	ID DB (°F)	80	80	75	80	80	80	80	75	80	80	80	80	75	80	80
	ID WB (°F)	57	62	62	67	72	57	62	62	67	72	57	62	62	67	72
65	T.C.	38.1	44.0	43.9	47.7	52.4	39.7	44.2	44.3	48.1	53.0	41.4	44.3	44.7	48.5	53.5
	S.C.	37.2	35.7	30.6	30.0	24.5	38.8	36.5	31.2	30.6	24.9	40.4	37.3	31.7	31.2	25.3
	K.W.	3.20	1.94	1.94	1.91	1.92	2.79	1.94	1.94	1.91	1.90	2.37	1.95	1.94	1.92	1.88
75	T.C.	37.5	42.0	42.0	45.7	50.2	39.2	42.4	42.3	46.1	50.8	40.8	42.8	42.7	46.5	51.3
	S.C.	36.6	35.0	29.8	29.4	23.8	38.2	35.8	30.4	30.0	24.2	39.8	36.6	30.9	30.6	24.6
	K.W.	3.20	2.36	2.36	2.33	2.34	2.78	2.36	2.36	2.34	2.32	2.37	2.37	2.36	2.35	2.31
85	T.C.	37.0	40.1	40.0	43.8	48.1	38.6	40.7	40.4	44.2	48.6	40.2	41.3	40.7	44.5	49.1
	S.C.	36.1	34.2	29.0	28.7	23.1	37.7	35.0	29.6	29.3	23.5	39.2	35.8	30.1	29.9	23.8
	K.W.	3.20	2.78	2.78	2.75	2.76	2.78	2.78	2.78	2.76	2.75	2.37	2.78	2.78	2.77	2.74
95	T.C.	36.5	38.2	38.1	41.9	45.9	38.1	39.0	38.4	42.2	46.4	39.7	39.8	38.7	42.5	46.9
	S.C.	35.6	33.5	28.2	28.1	22.4	37.1	34.3	28.8	28.7	22.7	38.7	35.0	29.3	29.2	23.1
	K.W.	3.20	3.19	3.20	3.17	3.17	2.78	3.20	3.20	3.18	3.17	2.37	3.20	3.20	3.19	3.17
105	T.C.	34.2	35.5	35.3	38.8	42.7	35.4	36.1	35.6	39.1	43.1	36.6	36.7	35.8	39.3	43.5
	S.C.	33.4	31.9	26.7	26.8	21.0	34.6	32.6	27.3	27.3	21.4	35.7	33.2	27.8	27.8	21.8
	K.W.	3.76	3.75	3.75	3.73	3.73	3.48	3.75	3.75	3.74	3.73	3.20	3.76	3.76	3.75	3.74
115	T.C.	32.0	32.9	32.6	35.8	39.7	32.8	33.3	32.9	36.0	39.9	33.5	33.7	33.1	36.3	40.2
	S.C.	31.3	30.4	25.3	25.4	19.7	32.0	30.9	25.9	25.9	20.1	32.8	31.5	26.4	26.4	20.5
	K.W.	4.30	4.29	4.29	4.28	4.28	4.16	4.29	4.29	4.28	4.28	4.02	4.29	4.29	4.29	4.28
125	T.C.	29.9	30.3	30.0	32.7	36.6	30.2	30.5	30.1	33.0	36.7	30.5	30.6	30.3	33.2	36.9
	S.C.	29.2	28.9	23.9	24.1	18.3	29.5	29.3	24.4	24.5	18.8	29.8	29.7	24.9	24.9	19.3
	K.W.	4.84	4.82	4.83	4.83	4.83	4.83	4.83	4.83	4.83	4.83	4.83	4.83	4.83	4.83	4.83

NOTE: ALL CAPACITIES ARE NET (KBTUH) WITH INDOOR FAN HEAT ALREADY DEDUCTED AT 1250 BTUH/1000 CFM.

Multipliers for determining the performance with other indoor sections.

NOTE: For dry bulb temperatures different than those listed (between 73-87 F), sensible capacity increases by 1060 BTUH per 1000 CFM per degree above the listed temperature and decreases by 1060 BTUH per 1000 CFM per degree below the listed temperature.

NOTE: KW RATING IS FOR OUTDOOR AND INDOOR UNITS.

LOW CFM

Air Handler	Coil	T.C.	S.C.	KW
AV/SV60D	-	0.99	0.99	1.00
F4FV060	-	0.99	0.99	1.02
MV20D	FC/MC/PC60D	0.95	0.95	1.00
MV20D	UC60D	0.95	0.95	1.00
MV20D	FC/MC62D	1.00	1.00	1.00

Variable Speed Furnace	Coil	T.C.	S.C.	KW
(F,L)C8V*C20	FC/PC60C	0.97	0.97	1.01
(F,L)C8V*C20	FC/MC/PC60D	0.97	0.97	1.01
(F,L)C8V*C20	UC60D	0.97	0.97	1.01
(F,L)C9(C,V)*C20	FC/PC60C	0.96	0.96	1.01
(F,L)C9(C,V)*C20	FC/MC/PC60D	0.96	0.96	1.01
(F,L)C9(C,V)*C20	UC60D	0.96	0.96	1.01
(F,L)C9(C,V)*D20	FC/MC/PC60D	0.95	0.95	1.00
(F,L)C9(C,V)*D20	UC60D	0.95	0.95	1.00
(F,L)C8V*C20	FC/MC62D	1.02	1.02	1.01
(F,L)C9(C,V)*C20	FC/MC62D	1.01	1.01	1.00
(F,L)C9(C,V)*D20	FC/MC62D	1.00	1.00	1.00

Variable Speed Furnace	Coil	T.C.	S.C.	KW
(F,L)C9(C,V)*D20	HC60D	0.95	0.95	1.00
C*9C*D20	FC/MC62D	0.98	0.97	1.03
C*(8,L)C*C20	FC/PC60C	0.97	0.95	1.01
C*9C*C20	FC/PC60C	0.97	0.95	1.02
C*9C*D20	HC60	0.95	0.94	1.02
C*(8,L)C*C20	HD60	0.98	0.95	1.01
C*9C*C20	HD60	0.98	0.97	1.03
C*9C*D20	HD60	0.99	0.97	1.03
C*(8,L)C*C20	UC60C	0.94	0.91	1.01
C*9C*C20	UC60C	0.93	0.90	1.02
C*9C*D20	UC60D	0.94	0.92	1.02
G*9V*D20	FC/MC62D	0.98	0.97	1.03
G*9V*C20	FC/PC60C	0.97	0.95	1.02
G*9V*D20	HC60	0.95	0.94	1.02
G*9V*C20	HD60	0.98	0.97	1.03
G*9V*D20	HD60	0.99	0.97	1.03
G*9V*C20	UC60C	0.93	0.90	1.02
G*9V*D20	UC60D	0.94	0.92	1.02

COOLING PERFORMANCE DATA - HIGH CFM 2-STAGE OPERATION

OUTDOOR UNIT MODEL NO.		AC8B060F1														
INDOOR COIL MODEL NO.		FC62D + MV20D														
CONDENSER ENTERING AIR TEMPERATURE	ID CFM	1750					1850					1950				
	ID DB (°F)	80	80	75	80	80	80	80	75	80	80	80	80	75	80	80
	ID WB (°F)	57	62	62	67	72	57	62	62	67	72	57	62	62	67	72
65	T.C.	57.1	61.0	60.6	66.2	71.1	58.0	61.4	61.2	66.8	72.2	58.8	61.6	61.8	67.3	73.3
	S.C.	58.1	53.7	44.6	44.7	36.4	59.0	54.7	46.2	45.8	36.6	59.8	55.6	47.7	46.8	36.8
	K.W.	3.20	3.25	3.26	3.32	3.36	3.27	3.32	3.31	3.39	3.44	3.36	3.40	3.38	3.47	3.53
75	T.C.	55.3	58.5	58.0	63.4	68.2	56.0	58.8	58.4	63.9	68.9	56.7	59.1	58.7	64.3	69.5
	S.C.	56.3	52.5	43.9	43.6	34.8	57.0	53.5	44.9	44.6	34.9	57.7	54.5	45.8	45.6	34.9
	K.W.	3.69	3.74	3.74	3.80	3.86	3.77	3.80	3.79	3.87	3.93	3.85	3.88	3.86	3.95	4.01
85	T.C.	53.6	55.9	55.4	60.6	65.3	54.1	56.2	55.5	60.9	65.5	54.6	56.5	55.6	61.2	65.8
	S.C.	54.5	51.3	43.2	42.5	33.1	55.1	52.4	43.6	43.5	33.1	55.6	53.4	44.0	44.4	33.0
	K.W.	4.19	4.23	4.22	4.29	4.35	4.26	4.29	4.28	4.35	4.41	4.34	4.36	4.35	4.43	4.49
95	T.C.	51.8	53.3	52.8	57.8	62.4	52.2	53.6	52.7	58.0	62.2	52.6	53.9	52.5	58.2	62.0
	S.C.	52.7	50.1	42.5	41.5	31.5	53.1	51.3	42.4	42.3	31.4	53.5	52.4	42.1	43.2	31.2
	K.W.	4.69	4.71	4.70	4.77	4.84	4.76	4.77	4.76	4.83	4.90	4.83	4.85	4.83	4.91	4.97
105	T.C.	48.6	49.8	49.3	53.9	58.3	49.1	50.1	49.3	54.1	58.2	49.5	50.4	49.2	54.2	58.1
	S.C.	49.5	47.7	40.5	39.8	30.1	50.0	48.7	40.7	40.6	30.1	50.4	49.6	40.8	41.3	30.1
	K.W.	5.39	5.40	5.38	5.46	5.54	5.46	5.47	5.44	5.53	5.60	5.54	5.55	5.52	5.60	5.67
115	T.C.	45.6	46.3	46.0	50.2	54.3	46.1	46.7	46.0	50.3	54.3	46.5	47.1	46.0	50.4	54.2
	S.C.	46.4	45.4	38.6	38.2	28.7	46.9	46.2	39.0	38.9	29.0	47.4	46.9	39.4	39.6	29.1
	K.W.	6.06	6.07	6.04	6.13	6.22	6.14	6.14	6.11	6.20	6.28	6.23	6.22	6.19	6.28	6.36
125	T.C.	42.6	42.8	42.6	46.4	50.3	43.1	43.3	42.7	46.5	50.4	43.5	43.7	42.7	46.5	50.4
	S.C.	43.4	43.2	36.6	36.6	27.4	43.9	43.7	37.4	37.2	27.8	44.3	44.1	38.1	37.8	28.2
	K.W.	6.74	6.75	6.71	6.80	6.89	6.82	6.82	6.78	6.87	6.96	6.91	6.90	6.86	6.96	7.04

NOTE: ALL CAPACITIES ARE NET (KBTUH) WITH INDOOR FAN HEAT ALREADY DEDUCTED AT 1250 BTUH/1000 CFM.

Multipliers for determining the performance with other indoor sections.

NOTE: For dry bulb temperatures different than those listed (between 73-87 F), sensible capacity increases by 1060 BTUH per 1000 CFM per degree above the listed temperature and decreases by 1060 BTUH per 1000 CFM per degree below the listed temperature.

NOTE: KW RATING IS FOR OUTDOOR AND INDOOR UNITS.

HIGH CFM

Air Handler	Coil	T.C.	S.C.	KW
AV/SV60D	-	0.96	0.96	0.99
F4FV060	-	0.96	0.96	0.99
MV20D	FC/MC/PC60D	0.96	0.96	0.99
MV20D	UC60D	0.96	0.96	0.99
MV20D	FC/MC62D	1.00	1.00	1.00

Variable Speed Furnace	Coil	T.C.	S.C.	KW
C*9C*D20	FC/MC62D	0.97	0.94	1.02
C*(8,L)C*C20	FC/PC60C	0.96	0.93	1.00
C*9C*C20	FC/PC60C	0.96	0.93	1.02
C*9C*D20	HC60	0.94	0.90	1.01
C*(8,L)C*C20	HD60	0.97	0.93	1.00
C*9C*C20	HD60	0.97	0.94	1.03
C*9C*D20	HD60	0.96	0.92	1.02
C*(8,L)C*C20	UC60C	0.94	0.89	1.00
C*9C*C20	UC60C	0.93	0.89	1.02
C*9C*D20	UC60D	0.94	0.89	1.01
G*9V*D20	FC/MC62D	0.97	0.94	1.02
G*9V*C20	FC/PC60C	0.96	0.93	1.02
G*9V*D20	HC60	0.94	0.90	1.01
G*9V*C20	HD60	0.97	0.94	1.03
G*9V*D20	HD60	0.96	0.92	1.02
G*9V*C20	UC60C	0.93	0.89	1.02
G*9V*D20	UC60D	0.94	0.89	1.01

Variable Speed Furnace	Coil	T.C.	S.C.	KW
(F,L)C8V*C20	FC/PC60C	0.95	0.95	1.00
(F,L)C8V*C20	FC/MC/PC60D	0.95	0.95	1.00
(F,L)C8V*C20	UC60D	0.95	0.95	1.00
(F,L)C9(C,V)*C20	FC/PC60C	0.93	0.93	0.99
(F,L)C9(C,V)*C20	FC/MC/PC60D	0.93	0.93	0.99
(F,L)C9(C,V)*C20	UC60D	0.93	0.93	0.99
(F,L)C9(C,V)*D20	FC/MC/PC60D	0.93	0.93	0.98
(F,L)C9(C,V)*D20	UC60D	0.93	0.93	0.98
(F,L)C8V*C20	FC/MC62D	0.98	0.98	1.01
(F,L)C9(C,V)*C20	FC/MC62D	0.97	0.97	1.00
(F,L)C9(C,V)*D20	FC/MC62D	0.97	0.97	0.99
(F,L)C9(C,V)*D20	HC60D	0.94	0.94	0.98