



TECHNICAL GUIDE

SPLIT-SYSTEM AIR CONDITIONERS

13 SEER – R-410A

MODELS:
TCGD18 THRU 60
(1.5 THRU 5 NOMINAL TONS, 1 PHASE)



Due to continuous product improvement, specifications are subject to change without notice.

Visit us on the web at www.york.com

Additional rating information can be found at www.ahridirectory.org

DESCRIPTION

The 13 SEER Series condensing unit is the outdoor part of a versatile system of air conditioning. It is designed to be custom-matched with one of UPG's complete line of evaporator sections, with each serving a specific function. Matching Air Handlers are available for upflow, downflow, or horizontal applications to provide a complete system. Electric Heaters are available, if required. Add-on coils are available for use with upflow, downflow, or horizontal furnaces and air handlers.

WARRANTY

Single Phase Units:

5-year limited parts warranty.

5-year limited compressor warranty.

FEATURES

- **QUALITY CONDENSER COILS** - The coil is constructed of aluminum microchannel tubing and enhanced aluminum fins for increased efficiency and corrosion protection.
- **PROTECTED COMPRESSOR** - The compressor is internally protected against high pressure, temperature, and externally by a factory installed high pressure switch. This is accomplished by the simultaneous operation of high pressure relief valve and a temperature sensor which protects the compressor if undesirable operating conditions occur. A liquid line filter-drier further protects the compressor.
- **DURABLE FINISH** - The cabinet is made of pre-painted steel. The pre-treated galvanized steel provides a better paint to steel bond, which resists corrosion and rust creep. Special primer formulas and matted-textured finish insure less fading when exposed to sunlight.
- **LOWER INSTALLED COST** - Installation time and costs are reduced by easy power and control wiring connections. Available in sweat connect models only. The unit contains enough refrigerant for matching indoor coils and 15 feet of interconnecting piping. The small base dimension means less space is required on the ground or roof.
- **TOP DISCHARGE** - The warm air from the top mounted fan is blown up away from the structure and any landscaping. This allows compact location on multi-unit applications.
- **LOW OPERATING SOUND LEVEL** - The upward air flow carries the normal operating noise away from the living area. The rigid top panel effectively isolates any motor sound. Isolator mounted compressor and the rippled fins of the condenser coil muffle the normal fan motor and compressor operating sounds.
- **LOW MAINTENANCE** - Long life permanently lubricated motor-bearings need no annual servicing.
- **EASY SERVICE ACCESS** - Fully exposed refrigerant connections, and a single panel covering the electrical controls make for easy servicing of the unit.
- **SECURED SERVICE VALVES** - Secured re-usable service valves are provided on both the liquid and vapor sweat connections for ease of evacuating and charging.
- **U.L. and C.U.L. listed** - approved for outdoor application.
- **Agency Listed** - U.L. and C.U.L. listed - approved for outdoor application. The unit is certified in accordance with the Unitary Small Equipment certification program, which is based on ARI Standard 210/240.

Physical and Electrical Data

MODEL		TCGD18 S41S1(H)	TCGD24 S41S1(H)	TCGD30 S41S1(H)	TCGD36 S41S1(H)	TCGD42 S41S1(H)	TCGD48 S41S1(H)	TCGD60 S41S1
Unit Supply Voltage		208-230V, 1 ϕ , 60Hz						
Normal Voltage Range ¹		187 to 252						
Minimum Circuit Ampacity		10.0	12.4	14.7	17.9	21.5	21.1	34.3
Max. Overcurrent Device Amps ²		15	20	25	30	35	35	60
Min. Overcurrent Device Amps ³		15	15	15	20	25	25	35
Compressor Type		Rotary	Recip	Recip	Recip	Recip	Recip	Scroll
Compressor Amps	Rated Load	7.6	9.3	10.6	13.1	16.0	15.7	26.2
	Locked Rotor	40.0	43.0	54.0	74	84	84	150
Crankcase Heater		No	No	No	No	No	No	No
Fan Motor Amps	Rated Load	0.5	0.8	1.4	1.5	1.5	1.5	1.5
Fan Diameter Inches		17.5	17.5	17.5	22	22	22	24
Fan Motor	Rated HP	1/12	1/8	1/4	1/4	1/4	1/4	1/4
	Nominal RPM	1100	1075	1100	850	850	850	850
	Nominal CFM	1400	1950	2050	3200	2950	2950	3600
Coil	Face Area Sq. Ft.	9.60	9.60	9.60	13.07	14.16	14.16	18.68
	Rows Deep	1	1	1	1	1	1	1
	Fin / Inches	23	23	23	23	23	23	23
Liquid Line Set OD (Field Installed)		3/8	3/8	3/8	3/8	3/8	3/8	3/8
Vapor Line Set OD (Field Installed)		5/8	3/4	3/4	3/4	7/8	7/8	7/8
Unit Charge (Lbs. - Oz.) ⁴		3 - 3	3 - 13	3 - 14	4 - 9	4 - 5	4 - 9	5 - 6
Charge Per Foot, Oz.		0.58	0.62	0.62	0.62	0.67	0.67	0.67
Operating Weight Lbs.		97	129	131	145	173	173	195

Models with "H" on the end of the model number have a factory installed start kits.

1. Rated in accordance with ARI Standard 110, utilization range "A".
2. Dual element fuses or HACR circuit breaker. Maximum allowable overcurrent protection.
3. Dual element fuses or HACR circuit breaker. Minimum recommended overcurrent protection.
4. The Unit Charge is correct for the outdoor unit, matched indoor coil and 15 feet of refrigerant tubing. For tubing lengths other than 15 feet, add or subtract the amount of refrigerant, using the difference in length multiplied by the per foot value.

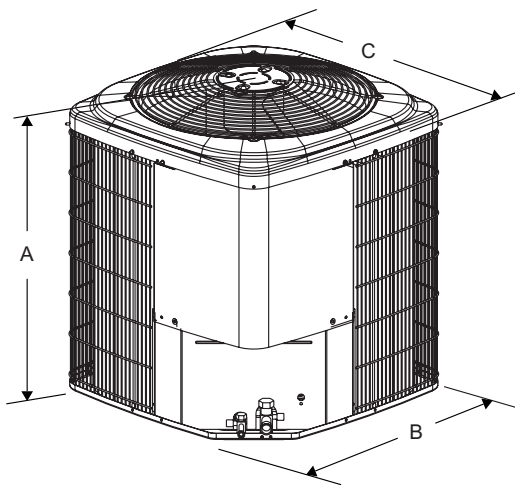

All dimensions are in inches. They are subject to change without notice. Certified dimensions will be provided upon request.

Unit Model	Dimensions (Inches)			Refrigerant Connection Service Valve Size	
	A ¹	B	C	Liquid	Vapor
18	28	23-1/2	23-1/2	3/8"	3/4"
24	28	23-1/2	23-1/2		
30	28	23-1/2	23-1/2		
36	28	29	29		
42	30	29	29	7/8"	
48	30	29	29		
60	32	33-5/8	33-5/8		

1. Including Fan Guard.

Additional R-410A Charge / Orifice Size for Various Matched Systems							
Outdoor Unit	TCGD18 S41S1(H)	TCGD24 S41S1(H)	TCGD30 S41S1(H)	TCGD36 S41S1(H)	TCGD42 S41S1(H)	TCGD48 S41S1(H)	TCGD60 S41S1
Required Orifice or TXV ^{1,2}	0.048/902/4F1	0.055/902/4F1	0.061/907/4M1	0.065/903/4G1	0.075/903/4G1	0.073/904/4H1	0.087/905/4J1
Factory Charge, lbs-oz	3 - 3	3 - 13	3 - 14	4 - 9	4 - 5	4 - 9	5 - 6
Indoor Coil ^{3,4}	Additional Charge, Oz						
FC/MC/PC/UC18A3X	0	-	-	-	-	-	-
FC/MC/PC/UC18B3X	0	-	-	-	-	-	-
FC/MC/PC/PC32A3X	-	4	0	-	-	-	-
FC/MC/PC/PC35B3X	-	4	0	-	-	-	-
FC/MC/PC/PC35C3X	-	4	0	-	-	-	-
FC/MC/PC/UC36A3X	-	0	-	-	-	-	-
FC/MC/PC/UC36B3X	-	0	-	-	-	-	-
FC/MC/PC/UC36C3X	-	0	-	-	-	-	-
FC/MC/PC/PC37A3X	-	4	2	0	-	-	-
FC/MC/PC/PC43B3X	-	4	2	0	0	-	-
FC/MC/PC/PC43C3X	-	4	2	0	0	-	-
FC/MC/PC/UC48C3X	-	-	-	8	2	4	-
FC/MC/PC/UC48D3X	-	-	-	8	2	4	-
FC/MC/PC/UC60D3X	-	-	-	-	-	0	0
FC/MC62D3X	-	-	-	-	-	-	4
HC18A3X	0	-	-	-	-	-	-
HC30A3X	-	0	-	-	-	-	-
HC36B3X	-	4	0	-	-	-	-
HC42C3X	-	4	2	0	0	-	-
HC60D3X	-	-	-	-	-	-	0
AHP18B3X	0	-	-	-	-	-	-
AHP30B3X	-	4	0	-	-	-	-
AHP36C3X	-	-	2	0	-	-	-
AHP42C3X	-	-	-	0	0	-	-
AHP/SHP60D3X	-	-	-	-	-	0	0
AV36C3X	-	4	2	0	-	-	-
AV/SV48D3X	-	-	-	-	-	0	-
AV60D3X	-	-	-	-	-	-	0
F4FP024 See Caution below	0	-	-	-	-	-	-
F4FP036 See Caution below	-	0	-	-	-	-	-
F4FP040 See Caution below	-	-	0	-	-	-	-
F5FP048 See Caution below	-	-	-	8	2	4	-
F5FP060 See Caution below	-	-	-	-	-	0	0
F4FV060 See Caution below	-	-	-	-	-	0	0

FOOTNOTES:

1. For applications requiring a TXV use 1TVM series kit.
2. Approved orifice shipped with outdoor unit.
3. Systems matched with furnace or air handlers not equipped with blower-off delays may require blower Time Delay Kit 2FD06700224.
4. PC coils cannot be used in downflow or horizontal applications. FC coils cannot be used in horizontal applications.

PROCEDURES:

1. Unit factory charge listed on the unit nameplate includes refrigerant for the condenser, the smallest evaporator and 15 feet of interconnecting line tubing.
2. Verify the TXV or orifice and additional charge required for specific evaporator coil in the system using the above table.
3. Additional charge for the amount of interconnecting line tubing greater than 15 feet at the rate specified in Physical and Electrical Data Table.
4. For TXV match charge weight needs to be weighed in for specific coil match and lineset length.
5. Permanently mark the unit nameplate with the total system charge. Total System Charge = Base Charge (as shipped) + adder for evaporator + adder for line set.

IMPORTANT

Models 12-48 require start kits for TXV matches. Models with "H" on the end of the model number have factory installed start kits. For models without an "H" refer to tech guide for kit number reference.

CAUTION

*F*FP Air Handlers come with a factory installed R-22 TXV which **MUST BE CHANGED OUT** to R-410A TXV or an orifice for proper operation. If the TXV is not changed out system damage will occur.*

COOLING CAPACITY - With Air Handler Coils

UNIT MODEL	AIR HANDLER		COIL MODEL ¹	COOLING				
	MODEL	W		RATED CFM	NET MBH		SEER	EER
					TOTAL	SENS.		
13 SEER AC WITH MA								
TCGD18S41S1(H)	MA08B	17	FC/MC18B	600	17.5	12.9	13.00	11.00
TCGD24S41S1(H)	MA08B	17	FC/MC36B	800	24.0	16.7	13.00	11.00
	MA08B	17	FC/MC35B	800	24.0	16.7	13.00	11.00
	MA08B	17	FC/MC43B	800	24.0	16.7	13.00	11.00
TCGD30S41S1(H)	MA12B	17	FC/MC35B	1000	29.0	21.0	13.00	11.00
	MA12B	17	FC/MC43B	1000	29.0	21.0	13.00	11.00
TCGD36S41S1(H)	MA12B	17	FC/MC43B	1200	35.0	24.8	13.00	11.00
	MA14D	24	FC/MC48D	1200	35.0	24.8	13.00	11.00
TCGD42S41S1(H)	MA16C	21	FC/MC43C	1400	42.0	29.2	13.00	11.00
	MA14D	24	FC/MC48D	1400	42.0	29.2	13.00	11.00
	MA16C	21	FC/MC48C	1400	42.0	29.2	13.00	11.00
TCGD48S41S1(H)	MA16C	21	FC/MC48C	1600	48.0	34.4	13.00	11.00
	MA20D	24	FC/MC48D	1600	48.0	34.4	13.00	11.00
	MA16C	21	FC60C	1600	48.0	34.4	13.00	11.00
	MA20D	24	FC/MC60D	1600	48.0	34.4	13.00	11.00
TCGD60S41S1	MA20D	24	FC/MC60D	1800	57.0	38.5	13.00	11.00
	MA20D	24	FC/MC62D	1800	57.0	38.5	13.00	11.00
13 SEER AC WITH MV - VARIABLE SPEED								
TCGD18S41S1(H)	MV12B	17	FC/MC18B	600	17.5	13.3	14.00	12.50
TCGD24S41S1(H)	MV12B	17	FC/MC36B	800	24.0	17.4	14.00	12.00
	MV12B	17	FC/MC35B	800	24.0	17.4	14.00	12.00
	MV12B	17	FC/MC43B	800	24.0	17.3	14.00	12.00
TCGD30S41S1(H)	MV12B	17	FC/MC35B	1000	29.0	21.6	14.00	12.00
	MV16C	21	FC/MC35C	1000	30.0	21.6	14.00	12.00
	MV12B	17	FC/MC43B	1000	29.0	21.6	14.00	12.00
	MV16C	21	FC/MC43C	1000	30.0	21.6	14.00	12.00
TCGD36S41S1(H)	MV16C	21	FC/MC43C	1200	36.0	25.4	14.00	12.00
	MV16C	21	FC/MC48C	1200	36.0	25.4	14.00	12.00
	MV20D	24	FC/MC48D	1200	36.0	25.6	14.00	12.00
	MV12D	24	FC/MC48D	1135	35.0	25.4	14.00	12.00
TCGD42S41S1(H)	MV16C	21	FC/MC43C	1400	42.0	30.0	13.50	12.00
	MV16C	21	FC/MC48C	1400	42.0	30.0	13.50	12.00
	MV20D	24	FC/MC48D	1400	42.0	30.0	14.00	12.00
TCGD48S41S1(H)	MV16C	21	FC/MC48C	1600	48.0	35.0	13.50	12.00
	MV20D	24	FC/MC48D	1600	48.0	35.0	13.50	12.00
	MV20D	24	FC/MC60D	1600	48.0	35.0	13.50	12.00
TCGD60S41S1	MV20D	24	FC/MC60D	1800	57.0	38.5	13.00	11.00
	MV20D	24	FC/MC62D	1800	57.0	38.5	13.00	11.00
13 SEER AC WITH AV / SV / F*FV - VARIABLE SPEED								
TCGD24S41S1(H)	AV36	21	-	765	24.0	17.4	14.00	12.00
TCGD30S41S1(H)	AV36	21	-	1015	30.0	21.8	14.00	12.00
TCGD36S41S1(H)	AV36	21	-	1270	35.0	25.2	14.00	12.00
TCGD48S41S1(H)	AV/SV48	24	-	1610	48.0	35.0	13.50	12.00
	AV/SV60	24	-	1655	48.0	35.0	13.50	12.00
	F4FV060	24	-	1600	48.0	34.4	14.00	11.50
TCGD60S41S1	AV/SV60	24	-	1765	58.0	39.0	13.50	11.00
	F4FV060	24	-	1780	57.0	38.5	13.50	11.00

For Notes See Page 6.

COOLING CAPACITY - With Air Handler Coils (Continued)

UNIT MODEL	AIR HANDLER		COIL MODEL ¹	COOLING				
	MODEL	W		RATED CFM	NET MBH		SEER	EER
					TOTAL	SENS.		
13 SEER AC WITH AHP / SHP / F*FP								
TCGD18S41S1(H)	AHP18	17	—	650	17.5	12.9	13.00	11.00
	F4FP024	18	—	600	17.5	12.9	13.00	11.00
TCGD24S41S1(H)	AHP30	17	—	795	24.0	16.8	13.00	11.00
	F4FP036	21.5	—	800	24.0	16.7	13.00	11.00
TCGD30S41S1(H)	AHP30	17	—	1015	29.0	21.0	13.00	11.00
	AHP36	21	—	1040	29.0	21.0	13.00	11.00
	F4FP040	18	—	1050	29.0	21.0	13.00	11.00
TCGD36S41S1(H)	AHP36	21	—	1235	35.0	24.8	13.00	11.00
	AHP42	21	—	1255	35.0	24.8	13.00	11.00
	F5FP048	24	—	1235	35.0	24.8	13.00	11.00
TCGD42S41S1(H)	AHP42	21	—	1485	41.0	29.2	13.00	11.00
	F5FP048	24	—	1455	41.0	29.2	13.00	11.00
TCGD48S41S1(H)	AHP/SHP48	24	—	1675	48.0	34.4	13.00	11.00
	AHP/SHP60	24	—	1600	48.0	35.0	13.50	11.00
	F5FP048	24	—	1600	48.0	34.4	13.00	11.00
	F5FP060	24	—	1600	48.0	34.4	13.00	11.00
TCGD60S41S1	AHP/SHP60	24	—	1850	57.0	38.5	13.00	11.00
	F5FP060	24	—	1900	57.0	38.5	13.00	11.00

Rated in accordance with DOE test procedures (Federal Register 12-27-79 and 3-18-88) and ARI Standards 210.

Cooling MBH based on 80°F entering air temperature, 50% RH, and rated air flow.

EER (Energy Efficiency Ratio) is the total cooling output in BTU's at 95°F outdoor ambient divided by the total electric power in watt-hours at those conditions.

SEER (Seasonal Energy Efficiency Ratio) is the total cooling output in BTU's during a normal annual usage period for cooling divided by the total electric power input in watt-hours during the same period.

1. MC coils available with a factory installed horizontal drain pan. See price pages for specific model number.

— = Not applicable.

COOLING CAPACITY - Upflow, Downflow & Horizontal Furnaces and Coils

UNIT MODEL	FURNACE**		COIL MODEL	COOLING				
	CFM RANGE (Min.-max.)	W		RATED CFM	NET MBH		SEER ¹	EER
					TOTAL	SENS.		
TCGD18S41S1(H)	450 - 750	14,17	FC/MC/PC18	600	17.5	12.9	13.00	11.00
	450 - 750	14	HC18	600	17.5	12.9	13.00	11.00
	450 - 750	14,17	UC18	600	17.5	12.9	13.00	11.00
TCGD24S41S1(H)	600 - 1000	14	FC/MC/PC32	800	24.0	16.7	13.00	11.00
	600 - 1000	17,21	FC/MC/PC35	800	24.0	16.7	13.00	11.00
	600 - 1000	14,17,21	FC/MC/PC36	800	24.0	16.7	13.00	11.00
	600 - 1000	14	FC/MC/PC37	800	24.0	16.7	13.00	11.00
	600 - 1000	17,21	FC/MC/PC43	800	24.0	16.7	13.00	11.00
	600 - 1000	14	HC30	800	24.0	16.7	13.00	11.00
	600 - 1000	17	HC36	800	24.0	16.7	13.00	11.00
	600 - 1000	21	HC42	800	24.0	16.7	13.00	11.00
TCGD30S41S1(H)	800 - 1200	14	FC/MC/PC32	1000	29.0	21.0	13.00	11.00
	800 - 1200	17,21	FC/MC/PC35	1000	29.0	21.0	13.00	11.00
	800 - 1200	14	FC/MC/PC37	1000	29.0	21.0	13.00	11.00
	800 - 1200	17,21	FC/MC/PC43	1000	29.0	21.0	13.00	11.00
	800 - 1200	17	HC36	1000	29.0	21.0	13.00	11.00
	800 - 1200	21	HC42	1000	29.0	21.0	13.00	11.00
TCGD36S41S1(H)	1000 - 1400	14	FC/MC/PC37	1200	35.0	24.8	13.00	11.00
	1000 - 1400	17,21	FC/MC/PC43	1200	35.0	24.8	13.00	11.00
	1000 - 1400	21,24	FC/MC/PC48	1200	35.0	24.8	13.00	11.00
	1000 - 1400	21	HC42	1200	35.0	24.8	13.00	11.00
	1000 - 1400	21,24	UC48	1200	35.0	24.8	13.00	11.00
TCGD42S41S1(H)	1200 - 1600	17,21	FC/MC/PC43	1400	42.0	29.2	13.00	11.00
	1200 - 1600	21,24	FC/MC/PC48	1400	42.0	29.2	13.00	11.00
	1200 - 1600	21	HC42	1400	42.0	29.2	13.00	11.00
	1200 - 1600	21,24	UC48	1400	42.0	29.2	13.00	11.00
TCGD48S41S1(H)	1400 - 1800	21,24	FC/MC/PC48	1600	48.0	34.4	13.00	11.00
	1400 - 1800	21,24	FC/MC/PC60	1600	48.0	34.4	13.00	11.00
	1400 - 1800	24	HC60	1600	48.0	34.4	13.00	11.00
	1400 - 1800	21,24	UC48	1600	48.0	34.4	13.00	11.00
	1400 - 1800	21,24	UC60	1600	48.0	34.4	13.00	11.00
TCGD60S41S1	1600 - 2000	21,24	FC/MC/PC60	1800	57.0	38.5	13.00	11.00
	1600 - 2000	24	FC/MC62	1800	57.0	38.5	13.00	11.00
	1600 - 2000	24	HC60	1800	57.0	38.5	13.00	11.00
	1600 - 2000	21,24	UC60	1800	57.0	38.5	13.00	11.00

1. Requires a 2FD06700224 Blower Time Delay unless a standard furnace is equipped with one.

** Refer to Quick Selection Chart for specific furnace match-up.

COOLING CAPACITY - TCGD18S41S1(H) With Variable Speed Furnaces

VARIABLE SPEED FURNACE MODEL	COIL MODEL ¹	W	COOLING				
			RATED CFM	Net MBH		SEER	EER
				TOTAL	SENS.		
13 SEER HP WITH VARIABLE SPEED FURNACES²							
(F,L)C8V*A12	FC/MC/PC18A	14	600	17.5	13.4	14.00	12.50
FC9V*A12	FC/MC/PC18A	14	625	17.5	13.3	14.00	12.50
FC9(C,V)*B12	FC/MC/PC18B	17	620	17.5	13.3	14.00	12.50
(F,L)C8V*A12	HC18	14	600	17.5	13.4	14.00	12.50
FC9V*A12	HC18	14	625	17.5	13.3	14.00	12.50
C*(8,L)C*A12	FC/MC/PC18A	14	620	17.5	12.7	14.50	12.50
C*(8,L)C*B12	FC/MC/PC18B	17	580	17.5	12.6	14.50	12.00
C*9C*B12	FC/MC/PC18B	17	610	17.5	12.8	14.50	12.50
C*(8,L)C*A12	HC18	14	620	17.5	12.8	14.50	12.00
C*(8,L)C*A12	UC18A	14	620	17.5	12.7	14.50	12.00
C*(8,L)C*B12	UC18B	17	580	17.5	12.5	14.50	12.00
C*9C*B12	UC18B	17	610	17.5	12.6	14.50	12.50
G*9V*A12	FC/MC/PC18A	14	625	17.5	12.9	14.50	12.00
G*9V*B12	FC/MC/PC18B	17	610	17.5	12.8	14.50	12.50
G*9V*A12	HC18	14	625	17.5	12.9	14.50	12.00
G*9V*A12	UC18A	14	625	17.5	12.7	14.50	12.00
G*9V*B12	UC18B	17	610	17.5	12.6	14.50	12.50

1. MC coils available with a factory installed horizontal drain pan. See price pages for specific model number.

2. Variable speed furnaces have B.O.D (Blower on Delay) standard.

COOLING CAPACITY - TCGD24S41S1(H) With Variable Speed Furnaces

VARIABLE SPEED FURNACE MODEL	COIL MODEL ¹	W	COOLING				
			RATED CFM	Net MBH		SEER	EER
				TOTAL	SENS.		
13 SEER HP WITH VARIABLE SPEED FURNACES²							
(F,L)C8V*A12	FC/MC/PC32A	14	750	24.0	17.3	14.00	12.00
FC9V*A12	FC/MC/PC32A	14	800	24.0	17.1	13.50	12.00
FC9(C,V)*B12	FC/MC/PC35B	17	820	24.0	17.2	14.00	12.00
(F,L)C8V*A12	FC/MC/PC36A	14	750	24.0	17.3	14.00	12.00
FC9V*A12	FC/MC/PC36A	14	800	24.0	17.2	14.00	12.00
FC9(C,V)*B12	FC/MC/PC36B	17	820	24.0	17.2	14.00	12.00
(F,L)C8V*A12	FC/MC/PC37A	14	750	24.0	17.2	14.00	12.00
FC9V*A12	FC/MC/PC37A	14	800	24.0	17.2	14.00	12.00
FC9(C,V)*B12	FC/MC/PC43B	17	820	24.0	17.2	14.00	12.00
(F,L)C8V*A12	HC30	14	750	24.0	17.3	14.00	12.00
FC9V*A12	HC30	14	800	24.0	17.1	13.50	12.00
FC9(C,V)*B12	HC36	17	820	24.0	17.2	14.00	12.00
C*(8,L)C*A12	FC/MC/PC32A	14	775	24.0	17.0	14.00	11.50
C*(8,L)C*B12	FC/MC/PC35B	17	760	24.0	16.8	14.00	12.00
C*9C*B12	FC/MC/PC35B	17	815	24.0	17.1	14.00	12.00
C*(8,L)C*A12	FC/MC/PC36A	14	805	24.0	16.9	14.00	12.00
C*(8,L)C*B12	FC/MC/PC36B	17	765	24.0	17.0	14.00	12.00
C*9C*B12	FC/MC/PC36B	17	815	24.0	16.9	14.00	12.00
C*(8,L)C*A12	FC/MC/PC37A	14	805	24.0	17.0	14.00	12.00
C*(8,L)C*B12	FC/MC/PC43B	17	760	24.0	16.9	14.00	12.00
C*9C*B12	FC/MC/PC43B	17	800	24.0	17.0	14.00	12.00
C*(8,L)C*A12	HC30	14	775	23.8	16.8	13.80	11.50
C*(8,L)C*B12	HC36	17	760	24.0	16.8	14.00	12.00
C*9C*B12	HC36	17	815	24.0	17.2	14.00	12.00
C*(8,L)C*A12	UC36A	14	805	23.6	16.6	13.80	11.50
C*(8,L)C*B12	UC36B	17	765	23.6	16.7	14.00	11.50
C*9C*B12	UC36B	17	815	23.6	16.7	13.80	11.50
G*9V*A12	FC/MC/PC32A	14	800	24.0	16.9	13.70	11.50
G*9V*B12	FC/MC/PC35B	17	815	24.0	17.1	14.00	12.00
G*9V*A12	FC/MC/PC36A	14	800	24.0	16.9	14.00	11.50
G*9V*B12	FC/MC/PC36B	17	815	24.0	16.9	14.00	12.00
G*9V*A12	FC/MC/PC37A	14	800	24.0	17.0	14.00	12.00
G*9V*B12	FC/MC/PC43B	17	800	24.0	17.0	14.00	12.00
G*9V*A12	HC30	14	800	24.0	17.1	14.00	11.50
G*9V*B12	HC36	17	815	24.0	17.2	14.00	12.00
G*9V*A12	UC36A	14	800	23.4	16.5	13.50	11.50
G*9V*B12	UC36B	17	815	23.6	16.7	13.80	11.50

1. MC coils available with a factory installed horizontal drain pan. See price pages for specific model number.

2. Variable speed furnaces have B.O.D (Blower on Delay) standard.

COOLING CAPACITY - TCGD30S41S1(H) With Variable Speed Furnaces

VARIABLE SPEED FURNACE MODEL	COIL MODEL ¹	W	COOLING				
			RATED CFM	Net MBH		SEER	EER
				TOTAL	SENS.		
13 SEER HP WITH VARIABLE SPEED FURNACES²							
(F,L)C8V*A12	FC/MC/PC32A	14	975	29.0	21.6	14.00	12.00
FC9V*A12	FC/MC/PC32A	14	1000	29.0	21.4	13.50	12.00
(F,L)C8V*B16	FC/MC/PC35B	17	1050	29.0	21.6	14.00	12.00
FC9(C,V)*B12	FC/MC/PC35B	17	975	29.0	21.6	14.00	12.00
(F,L)C8V*C16	FC/MC/PC35C	21	1000	30.0	21.8	14.00	12.00
(F,L)C8V*C20	FC/MC/PC35C	21	1120	29.0	21.4	13.50	11.00
FC9(C,V)*C16	FC/MC/PC35C	21	1010	29.0	21.6	14.00	12.00
FC9(C,V)*C20	FC/MC/PC35C	21	1045	29.0	21.6	14.00	12.00
(F,L)C8V*A12	FC/MC/PC37A	14	975	29.0	21.6	14.00	12.00
FC9V*A12	FC/MC/PC37A	14	1000	30.0	21.4	13.50	12.00
(F,L)C8V*B16	FC/MC/PC43B	17	1050	29.0	21.6	14.00	12.00
FC9(C,V)*B12	FC/MC/PC43B	17	975	29.0	21.6	14.00	12.00
(F,L)C8V*C16	FC/MC/PC43C	21	1000	30.0	21.8	14.00	12.00
(F,L)C8V*C20	FC/MC/PC43C	21	1120	29.0	21.4	13.50	11.00
FC9(C,V)*C16	FC/MC/PC43C	21	1010	29.0	21.6	14.00	12.00
FC9(C,V)*C20	FC/MC/PC43C	21	1045	29.0	21.6	14.00	12.00
(F,L)C8V*B16	HC36	17	1050	29.0	21.6	14.00	12.00
FC9(C,V)*B12	HC36	17	975	29.0	21.6	14.00	12.00
(F,L)C8V*C16	HC42	21	1000	30.0	21.8	14.00	12.00
(F,L)C8V*C20	HC42	21	1120	29.0	21.4	13.50	11.00
FC9(C,V)*C16	HC42	21	1010	29.0	21.6	14.00	12.00
FC9(C,V)*C20	HC42	21	1045	29.0	21.6	14.00	12.00
C*(8,L)C*A12	FC/MC/PC32A	14	1045	29.2	21.8	13.20	11.00
C*(8,L)C*B12	FC/MC/PC35B	17	995	29.6	21.4	14.00	11.50
C*9C*B12	FC/MC/PC35B	17	1045	29.4	22.0	13.50	11.50
C*(8,L)C*C16	FC/MC/PC35C	21	1025	29.6	22.0	14.00	12.00
C*(8,L)C*C20	FC/MC/PC35C	21	1080	30.0	22.4	14.00	12.00
C*9C*C16	FC/MC/PC35C	21	1005	29.6	22.0	14.00	12.00
C*9C*C20	FC/MC/PC35C	21	985	29.6	22.0	14.00	12.00
C*(8,L)C*A12	FC/MC/PC37A	14	980	29.8	21.8	13.80	11.50
C*(8,L)C*B12	FC/MC/PC43B	17	990	30.0	22.0	14.00	12.00
C*9C*B12	FC/MC/PC43B	17	1035	30.0	22.0	13.80	11.50
C*(8,L)C*C16	FC/MC/PC43C	21	990	30.0	22.1	14.00	12.00
C*(8,L)C*C20	FC/MC/PC43C	21	1000	30.0	22.1	14.00	12.00
C*9C*C16	FC/MC/PC43C	21	1030	30.0	22.0	14.00	12.00
C*9C*C20	FC/MC/PC43C	21	995	30.0	22.1	14.00	12.00
C*(8,L)C*B12	HC36	17	995	29.6	21.4	14.00	11.50
C*9C*B12	HC36	17	1045	29.4	22.0	13.70	11.50
C*(8,L)C*C16	HC42	21	990	30.0	22.1	14.00	12.00
C*(8,L)C*C20	HC42	21	1000	30.0	22.1	14.00	12.00
C*9C*C16	HC42	21	1030	30.0	22.0	14.00	12.00
C*9C*C20	HC42	21	995	30.0	22.1	14.00	12.00
G*9V*A12	FC/MC/PC32A	14	1000	29.4	21.6	13.50	11.50
G*9V*B12	FC/MC/PC35B	17	1045	29.4	22.0	13.50	11.50
G*9V*C16	FC/MC/PC35C	21	1005	29.6	22.0	14.00	12.00
G*9V*C20	FC/MC/PC35C	21	985	29.6	22.0	14.00	12.00
G*9V*A12	FC/MC/PC37A	14	1000	30.0	22.0	13.80	11.50
G*9V*B12	FC/MC/PC43B	17	1035	30.0	22.0	13.80	11.50
G*9V*C16	FC/MC/PC43C	21	1030	30.0	22.0	14.00	12.00
G*9V*C20	FC/MC/PC43C	21	995	30.0	22.1	14.00	12.00
G*9V*B12	HC36	17	1045	29.4	22.0	13.70	11.50
G*9V*C16	HC42	21	1030	30.0	22.0	14.00	12.00
G*9V*C20	HC42	21	995	30.0	22.1	14.00	12.00

1. MC coils available with a factory installed horizontal drain pan. See price pages for specific model number.

2. Variable speed furnaces have B.O.D (Blower on Delay) standard.

COOLING CAPACITY - TCGD36S41S1(H) With Variable Speed Furnaces

VARIABLE SPEED FURNACE MODEL	COIL MODEL ¹	W	COOLING				
			RATED CFM	Net MBH		SEER	EER
				TOTAL	SENS.		
13 SEER HP WITH VARIABLE SPEED FURNACES²							
(F,L)C8V*A12	FC/MC/PC37A	14	1185	35.0	25.0	13.00	12.00
FC9V*A12	FC/MC/PC37A	14	1200	35.0	25.0	13.00	11.00
(F,L)C8V*B16	FC/MC/PC43B	17	1200	35.0	25.2	13.50	12.00
FC9(C,V)*B12	FC/MC/PC43B	17	1185	35.0	25.2	13.50	12.00
(F,L)C8V*C16	FC/MC/PC43C	21	1200	35.0	25.4	14.00	12.00
(F,L)C8V*C20	FC/MC/PC43C	21	1200	35.0	25.2	13.50	12.00
FC9(C,V)*C16	FC/MC/PC43C	21	1175	35.0	25.2	13.50	12.00
FC9(C,V)*C20	FC/MC/PC43C	21	1195	35.0	25.2	13.50	12.00
(F,L)C8V*C16	FC/MC/PC48C	21	1200	36.0	25.4	14.00	12.00
(F,L)C8V*C20	FC/MC/PC48C	21	1200	35.0	25.2	13.50	12.00
FC9(C,V)*C16	FC/MC/PC48C	21	1175	35.0	25.4	14.00	12.00
FC9(C,V)*C20	FC/MC/PC48C	21	1195	35.0	25.2	14.00	12.00
FC9(C,V)*D20	FC/MC/PC48D	24	1220	35.0	25.4	14.00	12.00
(F,L)C8V*C16	HC42	21	1200	36.0	25.4	14.00	12.00
(F,L)C8V*C20	HC42	21	1200	35.0	25.2	13.50	12.00
FC9(C,V)*C16	HC42	21	1175	35.0	25.2	14.00	12.00
FC9(C,V)*C20	HC42	21	1195	35.0	25.2	13.50	12.00
C*(8,L)C*A12	FC/MC/PC37A	14	980	33.8	23.0	13.50	11.00
C*(8,L)C*B12	FC/MC/PC43B	17	1210	35.2	25.2	13.50	11.00
C*9C*B12	FC/MC/PC43B	17	1200	35.2	25.2	13.50	11.00
C*(8,L)C*C16	FC/MC/PC43C	21	1205	35.6	25.4	14.00	11.50
C*(8,L)C*C20	FC/MC/PC43C	21	1190	35.6	25.4	14.00	12.00
C*9C*C16	FC/MC/PC43C	21	1240	35.4	25.2	13.50	11.50
C*9C*C20	FC/MC/PC43C	21	1200	35.6	25.4	14.00	11.50
C*(8,L)C*C16	FC/MC/PC48C	21	1210	36.0	26.0	14.00	12.00
C*(8,L)C*C20	FC/MC/PC48C	21	1155	36.0	26.1	14.00	12.00
C*9C*C16	FC/MC/PC48C	21	1195	36.0	26.0	14.00	11.50
C*9C*C20	FC/MC/PC48C	21	1330	36.0	26.5	14.00	11.50
C*9C*D20	FC/MC/PC48D	24	1240	36.0	26.2	14.00	12.00
C*(8,L)C*C16	HC42	21	1205	35.6	25.4	14.00	11.50
C*(8,L)C*C20	HC42	21	1190	35.6	25.6	14.00	12.00
C*9C*C16	HC42	21	1240	35.4	25.2	13.50	11.50
C*9C*C20	HC42	21	1200	35.6	25.4	14.00	11.50
C*(8,L)C*C16	UC48C	21	1210	34.6	24.8	13.50	11.50
C*(8,L)C*C20	UC48C	21	1155	34.8	24.8	14.00	11.50
C*9C*C16	UC48C	21	1195	34.6	24.8	13.50	11.50
C*9C*C20	UC48C	21	1305	35.0	25.6	13.30	11.00
C*9C*D20	UC48D	24	1240	34.8	25.0	13.80	11.50
G*9V*A12	FC/MC/PC37A	14	1100	34.6	24.0	13.30	11.00
G*9V*B12	FC/MC/PC43B	17	1200	35.2	25.2	13.50	11.00
G*9V*C16	FC/MC/PC43C	21	1240	35.4	25.2	13.50	11.50
G*9V*C20	FC/MC/PC43C	21	1200	35.6	25.4	14.00	11.50
G*9V*C16	FC/MC/PC48C	21	1195	36.0	26.0	14.00	11.50
G*9V*C20	FC/MC/PC48C	21	1330	36.0	26.5	14.00	11.50
G*9V*D20	FC/MC/PC48D	24	1240	36.0	26.2	14.00	12.00
G*9V*C16	HC42	21	1240	35.4	25.2	13.50	11.50
G*9V*C20	HC42	21	1200	35.6	25.4	14.00	11.50
G*9V*C16	UC48C	21	1195	34.6	24.8	13.50	11.50
G*9V*C20	UC48C	21	1305	35.0	25.6	13.30	11.00
G*9V*D20	UC48D	24	1240	34.8	25.0	13.80	11.50

1. MC coils available with a factory installed horizontal drain pan. See price pages for specific model number.

2. Variable speed furnaces have B.O.D (Blower on Delay) standard.

COOLING CAPACITY - TCGD42S41S1(H) With Variable Speed Furnaces

VARIABLE SPEED FURNACE MODEL	COIL MODEL ¹	W	COOLING				
			RATED CFM	Net MBH		SEER	EER
				TOTAL	SENS.		
13 SEER HP WITH VARIABLE SPEED FURNACES²							
(F,L)C8V*B16	FC/MC/PC43B	17	1400	42.0	29.6	13.00	12.00
(F,L)C8V*C20	FC/MC/PC43C	21	1400	42.0	29.8	13.50	12.00
FC9(C,V)*C16	FC/MC/PC43C	21	1415	42.0	29.6	13.00	11.00
FC9(C,V)*C20	FC/MC/PC43C	21	1370	42.0	29.8	13.50	12.00
(F,L)C8V*C16	FC/MC/PC48C	21	1400	42.0	29.6	13.50	12.00
(F,L)C8V*C20	FC/MC/PC48C	21	1400	42.0	29.8	13.50	12.00
FC9(C,V)*C16	FC/MC/PC48C	21	1415	42.0	29.6	13.00	11.00
FC9(C,V)*C20	FC/MC/PC48C	21	1370	42.0	29.8	13.50	12.00
FC9(C,V)*D20	FC/MC/PC48D	24	1360	42.0	30.0	13.50	12.00
(F,L)C8V*C16	HC42	21	1400	42.0	29.6	13.00	12.00
(F,L)C8V*C20	HC42	21	1400	42.0	29.8	13.50	12.00
FC9(C,V)*C16	HC42	21	1415	42.0	29.6	13.00	11.00
FC9(C,V)*C20	HC42	21	1370	42.0	29.8	13.50	12.00
C*(8,L)C*C16	FC/MC/PC43C	21	1425	42.0	30.0	13.50	11.50
C*(8,L)C*C20	FC/MC/PC43C	21	1450	42.0	30.4	13.50	11.50
C*9C*C16	FC/MC/PC43C	21	1360	42.0	29.6	13.30	11.00
C*9C*C20	FC/MC/PC43C	21	1395	42.0	29.6	13.50	11.00
C*(8,L)C*C16	FC/MC/PC48C	21	1435	42.0	30.1	13.80	11.50
C*(8,L)C*C20	FC/MC/PC48C	21	1410	42.0	30.1	14.00	11.50
C*9C*C16	FC/MC/PC48C	21	1395	42.0	30.3	13.50	11.50
C*9C*C20	FC/MC/PC48C	21	1430	42.0	30.3	13.50	11.50
C*9C*D20	FC/MC/PC48D	24	1450	42.0	29.9	13.80	11.50
C*(8,L)C*C16	HC42	21	1425	42.0	30.0	13.50	11.50
C*(8,L)C*C20	HC42	21	1450	42.0	30.0	13.50	11.50
C*9C*C16	HC42	21	1360	42.0	30.0	13.40	11.00
C*9C*C20	HC42	21	1395	42.0	30.0	13.50	11.00
C*(8,L)C*C16	UC48C	21	1435	41.5	30.2	13.50	11.00
C*(8,L)C*C20	UC48C	21	1410	41.5	30.2	13.50	11.50
C*9C*C16	UC48C	21	1395	41.5	30.2	13.30	11.00
C*9C*C20	UC48C	21	1430	41.5	30.0	13.20	11.00
C*9C*D20	UC48D	24	1450	41.5	30.2	13.40	11.00
G*9V*C16	FC/MC/PC43C	21	1360	42.0	29.6	13.30	11.00
G*9V*C20	FC/MC/PC43C	21	1395	42.0	29.6	13.50	11.00
G*9V*C16	FC/MC/PC48C	21	1395	42.0	30.3	13.50	11.50
G*9V*C20	FC/MC/PC48C	21	1430	42.0	30.3	13.50	11.50
G*9V*D20	FC/MC/PC48D	24	1450	42.0	29.9	13.80	11.50
G*9V*C16	HC42	21	1360	42.0	30.0	13.40	11.00
G*9V*C20	HC42	21	1395	42.0	30.0	13.50	11.00
G*9V*C16	UC48C	21	1395	41.5	30.2	13.30	11.00
G*9V*C20	UC48C	21	1430	41.5	30.0	13.20	11.00
G*9V*D20	UC48D	24	1450	41.5	30.2	13.40	11.00

1. MC coils available with a factory installed horizontal drain pan. See price pages for specific model number.

2. Variable speed furnaces have B.O.D (Blower on Delay) standard.

COOLING CAPACITY - TCGD48S41S1(H) With Variable Speed Furnaces

VARIABLE SPEED FURNACE MODEL	COIL MODEL ¹	W	COOLING				
			RATED CFM	Net MBH		SEER	EER
				TOTAL	SENS.		
13 SEER HP WITH VARIABLE SPEED FURNACES²							
(F,L)C8V*C16	FC/MC/PC48C	21	1500	47.0	34.6	13.00	11.00
(F,L)C8V*C20	FC/MC/PC48C	21	1610	48.0	34.6	13.00	11.00
FC9(C,V)*C16	FC/MC/PC48C	21	1600	48.0	34.4	13.00	11.00
FC9(C,V)*C20	FC/MC/PC48C	21	1580	48.0	34.6	13.00	11.00
FC9(C,V)*D20	FC/MC/PC48D	24	1560	48.0	35.0	13.00	12.00
(F,L)C8V*C16	FC/PC60C	21	1500	48.0	34.6	13.00	11.00
(F,L)C8V*C20	FC/PC60C	21	1610	48.0	34.6	13.00	11.00
FC9(C,V)*C16	FC/PC60C	21	1600	48.0	34.4	13.00	11.00
FC9(C,V)*C20	FC/PC60C	21	1580	48.0	34.6	13.00	11.00
FC9(C,V)*D20	FC/MC/PC60D	24	1560	48.0	35.0	13.00	12.00
C*(8,L)C*C16	FC/MC/PC48C	21	1615	48.0	34.4	13.30	11.00
C*(8,L)C*C20	FC/MC/PC48C	21	1640	48.0	34.8	13.20	11.00
C*9C*C16	FC/MC/PC48C	21	1590	48.0	34.6	13.10	11.00
C*9C*C20	FC/MC/PC48C	21	1655	48.0	34.8	13.20	11.00
C*9C*D20	FC/MC/PC48D	24	1645	48.0	35.2	13.20	11.00
C*9C*D20	FC/MC/PC60D	24	1615	48.0	35.0	13.20	11.00
C*(8,L)C*C16	FC/PC60C	21	1625	48.0	35.2	13.30	11.00
C*(8,L)C*C20	FC/PC60C	21	1605	48.0	35.0	13.50	11.50
C*9C*C16	FC/PC60C	21	1590	48.0	35.2	13.10	11.00
C*9C*C20	FC/PC60C	21	1655	48.0	35.2	13.10	11.00
G*9V*C16	FC/MC/PC48C	21	1590	48.0	34.6	13.10	11.00
G*9V*C20	FC/MC/PC48C	21	1655	48.0	34.8	13.20	11.00
G*9V*D20	FC/MC/PC48D	24	1645	48.0	35.2	13.20	11.00
G*9V*D20	FC/MC/PC60D	24	1615	48.0	35.0	13.20	11.00
G*9V*C16	FC/PC60C	21	1590	48.0	35.2	13.10	11.00
G*9V*C20	FC/PC60C	21	1655	48.0	35.2	13.10	11.00

1. MC coils available with a factory installed horizontal drain pan. See price pages for specific model number.

2. Variable speed furnaces have B.O.D (Blower on Delay) standard.

COOLING CAPACITY - TCGD60S41S1 With Variable Speed Furnaces

VARIABLE SPEED FURNACE MODEL	COIL MODEL ¹	W	COOLING				
			RATED CFM	Net MBH		SEER	EER
				TOTAL	SENS.		
13 SEER HP WITH VARIABLE SPEED FURNACES²							
(F,L)C8V*C20	FC/PC60C	21	1730	57.0	38.0	13.00	11.00
FC9(C,V)*C20	FC/PC60C	21	1650	56.0	39.0	13.00	11.00
FC9(C,V)*D20	FC/MC/PC60D	24	1620	56.0	39.0	13.00	11.00
(F,L)C8V*C20	FC/MC62D	21	1730	57.0	38.0	13.00	11.00
FC9(C,V)*C20	FC/MC62D	21	1650	56.0	39.0	13.00	11.00
FC9(C,V)*D20	FC/MC62D	24	1620	56.0	39.0	13.00	11.00
C*9C*D20	FC/MC/PC60D	24	1615	55.5	36.8	13.30	11.00
C*(8,L)C*C20	FC/MC62D	21	1615	56.5	37.4	13.50	11.00
C*9C*C20	FC/MC62D	21	1655	56.0	37.2	13.20	11.00
C*9C*D20	FC/MC62D	24	1630	56.0	37.4	13.30	11.00
C*(8,L)C*C20	FC/PC60C	21	1605	55.5	37.0	13.50	11.00
C*9C*C20	FC/PC60C	21	1655	55.0	36.8	13.30	11.00
C*9C*D20	HC60	24	1615	53.5	35.8	13.00	10.90
C*(8,L)C*C20	UC60C	21	1605	54.0	35.2	13.00	11.00
C*9C*C20	UC60C	21	1655	53.5	35.0	13.00	10.80
C*9C*D20	UC60D	24	1615	53.5	35.0	13.00	10.90
G*9V*D20	FC/MC/PC60D	24	1615	55.5	36.8	13.30	11.00
G*9V*C20	FC/MC62D	21	1655	56.0	37.2	13.20	11.00
G*9V*D20	FC/MC62D	24	1630	56.0	37.4	13.30	11.00
G*9V*C20	FC/PC60C	21	1655	55.0	36.8	13.30	11.00
G*9V*D20	HC60	24	1615	53.5	35.8	13.00	10.90
G*9V*C20	UC60C	21	1655	53.5	35.0	13.00	10.80
G*9V*D20	UC60D	24	1615	53.5	35.0	13.00	10.90

1. MC coils available with a factory installed horizontal drain pan. See price pages for specific model number.

2. Variable speed furnaces have B.O.D (Blower on Delay) standard.

ACCESSORIES

Refer to Price Manual for specific model numbers.

HARD START KIT - Required when using TXV indoor coil. Also, provides increased starting torque for areas with low voltage.

Model	Source 1 Kit numbers
18	S1-2SA06708606
24	S1-2SA06721706
30	S1-2SA06705906
36	S1-2SA06708906
42	S1-2SA06708806
48	S1-2SA06708806
60	S1-2SA06707906

OFF CYCLE TIMER DELAY - Provides a 5-minute off cycle to prevent rapid recycling of the compressor.

ROOM THERMOSTATS - A wide selection of compatible thermostats are available to provide optimum performance and features for any installation.

1H/1C, manual changeover electronic non-programmable thermostat.

1H/1C, auto/manual changeover, electronic programmable, deluxe 7-day, thermostat.

1H/1C, auto/manual changeover, electronic programmable.

* For the most current accessory information, refer to the price book or consult factory.

SOUND POWER RATINGS*

UNIT MODEL	(dBA)
18	75
24	76
30	76
36	76
42	76
48	77
60	78

* Rated in accordance with ARI 270-95 Standards.

TYPICAL INSTALLATION

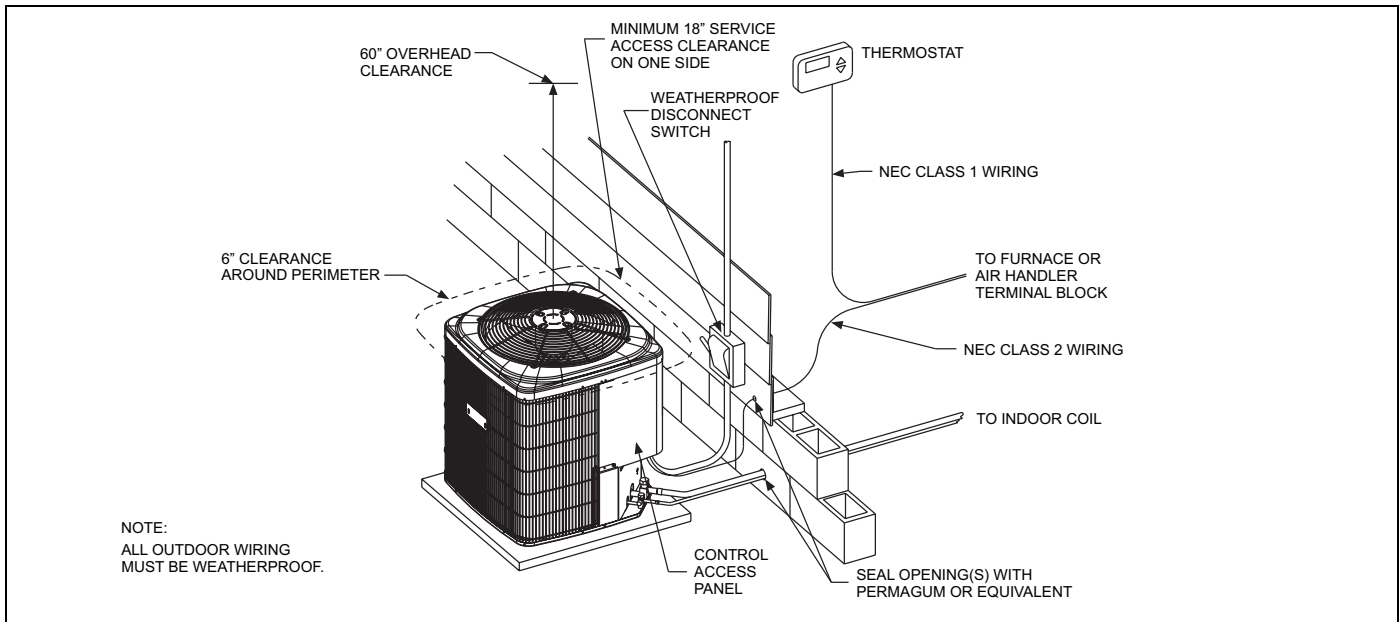

TYPICAL FIELD WIRING

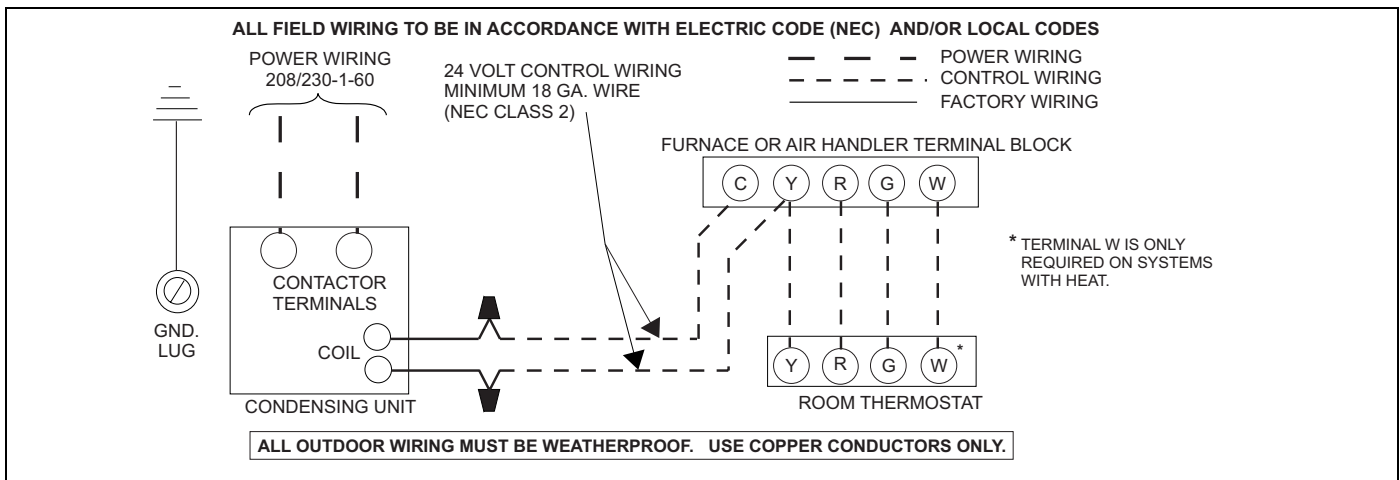

COOLING PERFORMANCE DATA																
AIR CONDITIONER MODEL NO.		TCGD18S41S1(H)														
INDOOR COIL MODEL NO.		FC/MC/PC18														
CONDENSING ENTERING AIR TEMPERATURE	IDCFM	450					600					750				
	ID DB (°F)	80	80	75	80	80	80	80	75	80	80	80	80	75	80	80
	ID WB (°F)	57	62	62	67	72	57	62	62	67	72	57	62	62	67	72
65	T.C.	15.7	17.8	17.7	19.3	19.9	16.9	18.4	18.0	19.5	20.2	18.0	18.9	18.4	19.6	20.4
	S.C.	16.0	13.8	12.1	12.0	9.3	17.3	15.9	13.5	13.0	9.8	18.5	17.9	14.9	13.9	10.4
	KW	1.0	0.9	0.9	0.9	0.9	0.9	0.9	0.9	0.9	0.9	0.9	0.9	0.9	0.9	0.9
75	T.C.	15.0	16.8	16.6	18.4	19.2	16.2	17.5	17.1	18.6	19.4	17.4	18.2	17.5	18.8	19.6
	S.C.	15.3	13.6	11.7	11.6	8.9	16.6	15.6	13.2	12.8	9.6	17.9	17.6	14.7	13.9	10.3
	KW	1.1	1.1	1.1	1.1	1.1	1.1	1.1	1.1	1.1	1.1	1.1	1.1	1.1	1.1	1.1
85	T.C.	14.2	15.8	15.6	17.4	18.5	15.5	16.6	16.1	17.7	18.6	16.8	17.4	16.7	18.1	18.8
	S.C.	14.5	13.4	11.2	11.2	8.6	15.9	15.3	12.8	12.6	9.4	17.2	17.2	14.4	13.9	10.1
	KW	1.2	1.2	1.2	1.2	1.2	1.2	1.2	1.2	1.2	1.2	1.2	1.2	1.2	1.2	1.2
95	T.C.	13.5	14.8	14.6	16.4	17.7	14.8	15.7	15.2	17.5	17.9	16.1	16.6	15.8	17.3	18.0
	S.C.	13.8	13.1	10.8	10.7	8.2	15.2	15.0	12.5	12.4	9.1	16.6	16.9	14.2	14.0	10.0
	KW	1.3	1.3	1.3	1.3	1.3	1.3	1.3	1.3	1.3	1.3	1.3	1.3	1.3	1.3	1.3
105	T.C.	12.6	13.7	13.2	15.1	16.5	13.8	14.6	13.8	15.5	16.7	15.0	15.5	14.4	16.0	16.8
	S.C.	12.8	12.5	10.2	10.3	7.9	14.1	14.1	11.8	11.9	8.8	15.4	15.7	13.4	13.6	9.8
	KW	1.5	1.5	1.5	1.5	1.5	1.5	1.5	1.5	1.5	1.5	1.5	1.5	1.5	1.5	1.5
115	T.C.	11.6	12.6	11.8	13.8	15.4	12.7	13.5	12.5	14.2	15.5	13.8	14.5	13.1	14.6	15.6
	S.C.	11.9	11.9	9.6	9.8	7.6	13.1	13.2	11.2	11.6	8.6	14.3	14.6	12.7	13.3	9.6
	KW	1.6	1.6	1.6	1.6	1.6	1.6	1.6	1.6	1.6	1.6	1.6	1.6	1.6	1.6	1.6
125	T.C.	10.7	11.4	10.5	12.5	14.2	11.7	12.4	11.2	12.9	14.3	12.7	13.4	11.8	13.3	14.4
	S.C.	11.0	11.2	9.0	9.4	7.3	12.1	12.3	10.5	11.2	8.3	13.1	13.5	12.0	12.9	9.4
	KW	1.8	1.8	1.8	1.8	1.8	1.8	1.8	1.8	1.8	1.8	1.8	1.8	1.8	1.8	1.8

NOTE: ALL CAPACITIES INCLUDE INDOOR FAN HEAT AT 1250 BTUH/1000 CFM.

Multippliers for determining the performance with other indoor sections.

NOTE: For dry bulb temperatures different than those listed (between 73-87 F), sensible capacity increases by 1060 BTUH per 1000 CFM per degree above the listed temperature and decreases by 1060 BTUH per 1000 CFM per degree below the listed temperature.

Air Handler	Coil	T.C.	S.C.	KW
-	HC18	1.00	1.00	1.00
-	UC18	1.00	1.00	1.00
AHP18	-	1.00	1.00	1.00
MV12B	FC/MC18B	1.02	1.03	0.89
MA08B	FC/MC18B	1.00	1.00	1.00
F4FP024	-	1.00	1.00	1.00

Variable Speed Furnace	Coil	T.C.	S.C.	KW
(F,L)C8V*A12	FC/MC/PC18A	1.02	1.03	0.89
FC9V*A12	FC/MC/PC18A	1.01	1.03	0.88
FC9(C,V)*B12	FC/MC/PC18B	1.02	1.03	0.89
(F,L)C8V*A12	HC18	1.02	1.03	0.89
FC9V*A12	HC18	1.01	1.03	0.88
C*(8,L)C*A12	FC/MC/PC18A	1.03	1.04	0.91
C*(8,L)C*B12	FC/MC/PC18B	1.01	1.02	0.89
C*9C*B12	FC/MC/PC18B	1.02	1.05	0.89
C*(8,L)C*A12	HC18	1.02	1.05	0.90
C*(8,L)C*A12	UC18A	1.03	1.05	0.91
C*(8,L)C*B12	UC18B	1.02	1.03	0.89
C*9C*B12	UC18B	1.03	1.05	0.89
G*9V*A12	FC/MC/PC18A	1.01	1.05	0.91
G*9V*B12	FC/MC/PC18B	1.02	1.05	0.89
G*9V*A12	HC18	1.01	1.05	0.91
G*9V*A12	UC18A	1.02	1.05	0.91
G*9V*B12	UC18B	1.03	1.05	0.89

COOLING PERFORMANCE DATA																
AIR CONDITIONER MODEL NO.		TCGD24S41S1(H)														
INDOOR COIL MODEL NO.		FC/MC/PC36														
CONDENSING ENTERING AIR TEMPERATURE	IDCFM	600					800					1000				
	ID DB (°F)	80	80	75	80	80	80	80	75	80	80	80	80	75	80	80
	ID WB (°F)	57	62	62	67	72	57	62	62	67	72	57	62	62	67	72
65	T.C.	22.0	27.4	27.3	29.1	30.3	24.3	28.8	28.6	30.4	31.7	26.6	30.1	29.8	31.8	33.2
	S.C.	22.0	19.9	17.3	17.0	13.8	24.2	22.9	19.6	18.8	14.8	26.4	26.0	22.0	20.6	15.7
	KW	1.5	1.5	1.5	1.5	1.5	1.5	1.5	1.5	1.5	1.5	1.5	1.5	1.5	1.5	1.5
75	T.C.	20.5	25.3	25.1	27.4	29.3	23.0	26.9	26.6	28.9	30.7	25.5	28.4	28.0	30.4	32.2
	S.C.	20.5	19.3	16.4	16.5	13.4	22.8	22.1	18.8	18.4	14.4	25.1	24.9	21.3	20.3	15.5
	KW	1.6	1.6	1.6	1.6	1.6	1.6	1.6	1.6	1.6	1.6	1.6	1.6	1.6	1.6	1.6
85	T.C.	19.0	23.2	23.0	25.8	28.3	21.7	25.0	24.6	27.4	29.7	24.4	26.7	26.1	28.9	31.2
	S.C.	19.0	18.6	15.6	15.9	12.9	21.4	21.2	18.1	18.0	14.1	23.9	23.7	20.5	20.0	15.3
	KW	1.7	1.7	1.7	1.7	1.8	1.7	1.7	1.7	1.8	1.8	1.7	1.7	1.7	1.8	1.8
95	T.C.	17.5	21.1	20.8	23.8	27.2	20.4	23.1	22.5	24.0	28.7	23.3	25.0	24.3	27.5	30.1
	S.C.	17.5	18.0	14.7	15.4	12.4	20.0	20.3	17.3	16.8	13.7	22.6	22.6	19.8	19.7	15.1
	KW	1.8	1.8	1.8	1.9	1.9	1.9	1.9	1.9	1.9	1.9	1.9	1.9	1.9	1.9	2.0
105	T.C.	16.2	19.0	18.4	21.7	24.8	18.7	21.0	20.2	23.3	26.3	21.3	22.9	22.0	24.9	27.7
	S.C.	16.1	16.6	13.7	14.4	11.6	18.4	18.6	15.9	16.6	13.0	20.6	20.6	18.2	18.8	14.5
	KW	2.0	2.0	2.0	2.0	2.1	2.0	2.0	2.0	2.0	2.1	2.0	2.0	2.0	2.1	2.1
115	T.C.	14.8	17.0	16.1	19.3	22.5	17.1	18.9	17.9	20.8	23.9	19.4	20.9	19.7	22.3	25.4
	S.C.	14.8	15.3	12.7	13.5	10.8	16.8	17.0	14.6	15.7	12.4	18.7	18.7	16.5	17.8	13.9
	KW	2.1	2.1	2.1	2.1	2.2	2.1	2.1	2.1	2.2	2.2	2.2	2.2	2.1	2.2	2.3
125	T.C.	13.5	14.9	13.8	16.8	20.1	15.5	16.9	15.6	18.3	21.6	17.5	18.9	17.4	19.8	23.1
	S.C.	13.5	13.9	11.7	12.5	10.1	15.1	15.4	13.3	14.7	11.7	16.8	16.8	14.9	16.9	13.3
	KW	2.2	2.2	2.2	2.3	2.4	2.3	2.3	2.2	2.3	2.4	2.3	2.3	2.3	2.3	2.4

NOTE: ALL CAPACITIES INCLUDE INDOOR FAN HEAT AT 1250 BTUH/1000 CFM.

Multipliers for determining the performance with other indoor sections.

NOTE: For dry bulb temperatures different than those listed (between 73-87 F), sensible capacity increases by 1060 BTUH per 1000 CFM per degree above the listed temperature and decreases by 1060 BTUH per 1000 CFM per degree below the listed temperature.

Air Handler	Coil	T.C.	S.C.	KW
–	FC/MC/PC32	1.00	1.00	1.00
–	FC/MC/PC35	1.00	1.00	1.00
–	FC/MC/PC37	1.00	1.00	1.00
–	FC/MC/PC43	1.00	1.00	1.00
–	HC30	1.00	1.00	1.00
–	HC36	1.00	1.00	1.00
–	HC42	1.00	1.00	1.00
–	UC36	1.00	1.00	1.00
AHP30	–	1.00	1.00	1.00
AV36	–	1.00	1.04	0.91
MV12B	FC/MC36B	1.00	1.04	0.91
MA08B	FC/MC36B	1.00	1.00	1.00
MV12B	FC/MC35B	1.00	1.04	0.91
MA08B	FC/MC35B	1.00	1.00	1.00
MV12B	FC/MC43B	1.00	1.03	0.91
MA08B	FC/MC43B	1.00	1.00	1.00
F4FP36	–	1.00	1.00	1.00

Variable Speed Furnace	Coil	T.C.	S.C.	KW
(F,L)C8(C,V)*A12	FC/MC/PC32A	1.00	1.03	0.91
FC9V*A12	FC/MC/PC32A	1.00	1.02	0.91
FC9(C,V)*B12	FC/MC/PC35B	1.00	1.02	0.91
(F,L)C8(C,V)*A12	FC/MC/PC36A	1.00	1.03	0.91
FC9V*A12	FC/MC/PC36A	1.00	1.02	0.91
FC9(C,V)*B12	FC/MC/PC36B	1.00	1.02	0.91
(F,L)C8V*A12	FC/MC/PC37A	1.00	1.03	0.91
FC9V*A12	FC/MC/PC37A	1.00	1.02	0.91
FC9(C,V)*B12	FC/MC/PC43B	1.00	1.02	0.91

Variable Speed Furnace	Coil	T.C.	S.C.	KW
(F,L)C8V*A12	HC30	1.00	1.03	0.91
FC9V*A12	HC30	1.00	1.02	0.91
FC9(C,V)*B12	HC36	1.00	1.02	0.91
C*(8,L)C*A12	FC/MC/PC32A	1.00	1.01	0.93
C*(8,L)C*B12	FC/MC/PC35B	1.00	1.01	0.92
C*9C*B12	FC/MC/PC35B	1.00	1.02	0.94
C*(8,L)C*A12	FC/MC/PC36A	1.00	1.01	0.93
C*(8,L)C*B12	FC/MC/PC36B	1.00	1.01	0.91
C*9C*B12	FC/MC/PC36B	1.00	1.01	0.92
C*(8,L)C*A12	FC/MC/PC37A	1.00	1.01	0.94
C*(8,L)C*B12	FC/MC/PC43B	1.00	1.00	0.92
C*9C*B12	FC/MC/PC43B	1.00	1.01	0.93
C*(8,L)C*A12	HC30	1.00	1.00	0.93
C*(8,L)C*B12	HC36	1.00	1.00	0.92
C*9C*B12	HC36	1.00	1.02	0.94
C*(8,L)C*A12	UC36A	0.98	0.99	0.92
C*(8,L)C*B12	UC36B	0.98	0.99	0.91
C*9C*B12	UC36B	0.98	0.99	0.92
G*9V*A12	FC/MC/PC32A	1.00	1.01	0.96
G*9V*B12	FC/MC/PC35B	1.00	1.02	0.94
G*9V*A12	FC/MC/PC36A	1.00	1.01	0.94
G*9V*B12	FC/MC/PC36B	1.00	1.01	0.92
G*9V*A12	FC/MC/PC37A	1.00	1.01	0.95
G*9V*B12	FC/MC/PC43B	1.00	1.01	0.93
G*9V*A12	HC30	1.00	1.01	0.94
G*9V*B12	HC36	1.00	1.02	0.94
G*9V*A12	UC36A	0.98	0.98	0.93
G*9V*B12	UC36B	0.98	0.99	0.92

COOLING PERFORMANCE DATA																
AIR CONDITIONER MODEL NO.		TCGD30S41S1(H)														
INDOOR COIL MODEL NO.		FC/MC/PC35														
CONDENSING ENTERING AIR TEMPERATURE	IDCFM	800					1000					1200				
	ID DB (°F)	80	80	75	80	80	80	80	75	80	80	80	80	75	80	80
	ID WB (°F)	57	62	62	67	72	57	62	62	67	72	57	62	62	67	72
65	T.C.	28.4	31.4	30.8	33.1	34.4	29.8	31.8	31.4	33.4	34.5	31.2	32.3	32.1	33.7	34.7
	S.C.	28.8	25.8	21.7	21.2	16.0	30.4	28.2	23.6	22.6	17.1	31.9	30.7	25.4	24.0	18.1
	KW	1.7	1.7	1.7	1.7	1.7	1.7	1.7	1.7	1.7	1.7	1.7	1.7	1.7	1.7	1.7
75	T.C.	26.4	28.8	28.2	30.9	32.6	27.9	29.7	28.9	31.4	32.8	29.5	30.5	29.6	31.8	32.9
	S.C.	26.9	24.7	20.5	20.3	15.4	28.5	27.1	22.6	22.0	16.4	30.2	29.5	24.6	23.7	17.5
	KW	1.8	1.8	1.8	1.9	1.9	1.8	1.8	1.8	1.9	1.9	1.9	1.9	1.9	1.9	1.9
85	T.C.	24.4	26.3	25.6	28.8	30.9	26.0	27.5	26.4	29.3	31.0	27.7	28.7	27.1	29.8	31.2
	S.C.	24.9	23.6	19.4	19.4	14.7	26.6	26.0	21.6	21.4	15.8	28.4	28.4	23.9	23.4	16.8
	KW	2.0	2.0	2.0	2.0	2.1	2.0	2.0	2.0	2.0	2.1	2.0	2.0	2.0	2.1	2.1
95	T.C.	22.4	23.8	23.0	26.7	29.1	24.2	25.3	23.8	29.0	29.3	26.0	26.9	24.7	27.9	29.4
	S.C.	22.9	22.5	18.2	18.5	14.1	24.8	24.9	20.7	21.2	15.1	26.7	27.3	23.1	23.1	16.2
	KW	2.1	2.1	2.1	2.2	2.3	2.2	2.2	2.2	2.2	2.3	2.2	2.2	2.2	2.2	2.3
105	T.C.	20.5	21.8	20.4	23.7	26.3	22.0	23.1	21.3	24.3	26.4	23.6	24.5	22.1	24.8	26.4
	S.C.	21.0	20.7	17.1	17.4	13.2	22.6	22.7	19.1	19.7	14.3	24.3	24.7	21.0	22.0	15.4
	KW	2.3	2.3	2.3	2.4	2.4	2.4	2.4	2.3	2.4	2.5	2.4	2.4	2.3	2.4	2.5
115	T.C.	18.6	19.8	17.9	20.9	23.5	19.9	21.0	18.8	21.4	23.5	21.2	22.2	19.6	21.8	23.6
	S.C.	19.1	18.9	15.9	16.4	12.3	20.5	20.5	17.5	18.6	13.5	22.0	22.2	19.1	20.9	14.7
	KW	2.5	2.5	2.4	2.5	2.6	2.5	2.5	2.5	2.5	2.6	2.6	2.6	2.5	2.6	2.6
125	T.C.	16.8	17.9	15.4	18.1	20.7	17.8	18.9	16.2	18.5	20.7	18.9	19.9	17.1	18.8	20.7
	S.C.	17.3	17.2	14.8	15.3	11.4	18.4	18.4	16.0	17.6	12.6	19.6	19.6	17.1	19.8	13.9
	KW	2.7	2.7	2.6	2.7	2.8	2.7	2.7	2.6	2.7	2.8	2.7	2.7	2.7	2.7	2.8

NOTE: ALL CAPACITIES INCLUDE INDOOR FAN HEAT AT 1250 BTUH/1000 CFM.

Multipliers for determining the performance with other indoor sections.

NOTE: For dry bulb temperatures different than those listed (between 73-87 F), sensible capacity increases by 1060 BTUH per 1000 CFM per degree above the listed temperature and decreases by 1060 BTUH per 1000 CFM per degree below the listed temperature.

Air Handler	Coil	T.C.	S.C.	KW
-	FC/MC/PC35	1.00	1.00	1.00
-	FC/MC/PC37	1.00	1.00	1.00
-	FC/MC/PC43	1.00	1.00	1.00
-	HC36	1.00	1.00	1.00
-	HC42	1.00	1.00	1.00
AHP30	-	1.00	1.00	1.00
AHP36	-	1.00	1.00	1.00
AV36	-	1.02	1.03	0.93
MV12B	FC/MC35B	1.01	1.02	0.92
MV16C	FC/MC35C	1.02	1.02	0.93
MA12B	FC/MC35B	1.00	1.00	1.00
MV12B	FC/MC43B	1.01	1.02	0.92
MV16C	FC/MC43C	1.02	1.02	0.93
MA12B	FC/MC43B	1.00	1.00	1.00
F4FP040	-	1.00	1.00	1.00

Continued on Page 18.

Variable Speed Furnace	Coil	T.C.	S.C.	KW
(F,L)C8V*A12	FC/MC/PC32A	1.01	1.02	0.92
FC9V*A12	FC/MC/PC32A	1.00	1.01	0.91
(F,L)C8V*B16	FC/MC/PC35B	1.01	1.02	0.92
FC9(C,V)*B12	FC/MC/PC35B	1.00	1.01	0.91
(F,L)C8V*C16	FC/MC/PC35C	1.01	1.02	0.92
(F,L)C8V*C20	FC/MC/PC35C	1.01	1.02	0.92
FC9(C,V)*C16	FC/MC/PC35C	1.01	1.02	0.92
FC9(C,V)*C20	FC/MC/PC35C	1.00	1.01	0.91
(F,L)C8V*A12	FC/MC/PC37A	1.01	1.02	0.92
FC9V*A12	FC/MC/PC37A	1.00	1.01	0.91
(F,L)C8V*B16	FC/MC/PC43B	1.01	1.02	0.92
(F,L)C8V*C16	FC/MC/PC43C	1.02	1.03	0.93
(F,L)C8V*C20	FC/MC/PC43C	1.00	1.01	1.00
FC9(C,V)*B12	FC/MC/PC43B	1.01	1.02	0.92
FC9(C,V)*C16	FC/MC/PC43C	1.01	1.02	0.92
FC9(C,V)*C20	FC/MC/PC43C	1.01	1.02	0.92
(F,L)C8V*B16	HC36	1.01	1.02	0.92
FC9(C,V)*B12	HC36	1.01	1.02	0.92
(F,L)C8V*C16	HC42	1.02	1.03	0.93
(F,L)C8V*C20	HC42	1.00	1.01	1.00
FC9(C,V)*C16	HC42	1.01	1.02	0.92
FC9(C,V)*C20	HC42	1.01	1.02	0.92
C*(8,L)C*A12	FC/MC/PC32A	1.01	1.03	0.99
C*(8,L)C*B12	FC/MC/PC35B	1.02	1.01	0.95
C*9C*B12	FC/MC/PC35B	1.02	1.04	0.97
C*(8,L)C*C16	FC/MC/PC35C	1.02	1.04	0.93

Variable Speed Furnace	Coil	T.C.	S.C.	KW
C*(8,L)C*C20	FC/MC/PC35C	1.03	1.06	0.94
C*9C*C16	FC/MC/PC35C	1.02	1.04	0.94
C*9C*C20	FC/MC/PC35C	1.02	1.04	0.93
C*(8,L)C*A12	FC/MC/PC37A	1.03	1.03	0.97
C*(8,L)C*B12	FC/MC/PC43B	1.03	1.04	0.95
C*9C*B12	FC/MC/PC43B	1.03	1.04	0.97
C*(8,L)C*C16	FC/MC/PC43C	1.03	1.04	0.93
C*(8,L)C*C20	FC/MC/PC43C	1.03	1.04	0.92
C*9C*C16	FC/MC/PC43C	1.03	1.04	0.95
C*9C*C20	FC/MC/PC43C	1.03	1.04	0.93
C*(8,L)C*B12	HC36	1.02	1.01	0.95
C*9C*B12	HC36	1.02	1.04	0.97
C*(8,L)C*C16	HC42	1.03	1.04	0.93
C*(8,L)C*C20	HC42	1.03	1.04	0.92
C*9C*C16	HC42	1.03	1.04	0.95
C*9C*C20	HC42	1.03	1.04	0.93
G*9V*A12	FC/MC/PC32A	1.01	1.02	0.96
G*9V*B12	FC/MC/PC35B	1.02	1.04	0.97
G*9V*C16	FC/MC/PC35C	1.02	1.04	0.94
G*9V*C20	FC/MC/PC35C	1.02	1.04	0.93
G*9V*A12	FC/MC/PC37A	1.03	1.03	0.97
G*9V*B12	FC/MC/PC43B	1.03	1.04	0.97
G*9V*C16	FC/MC/PC43C	1.03	1.04	0.95
G*9V*C20	FC/MC/PC43C	1.03	1.04	0.93
G*9V*B12	HC36	1.02	1.04	0.97
G*9V*C16	HC42	1.03	1.04	0.95
G*9V*C20	HC42	1.03	1.04	0.93

COOLING PERFORMANCE DATA																
AIR CONDITIONER MODEL NO.		TCGD36S41S1(H)														
INDOOR COIL MODEL NO.		FC/MC/PC43														
CONDENSING ENTERING AIR TEMPERATURE	IDCFM	1000					1200					1400				
	ID DB (°F)	80	80	75	80	80	80	80	75	80	80	80	80	75	80	80
	ID WB (°F)	57	62	62	67	72	57	62	62	67	72	57	62	62	67	72
65	T.C.	34.7	36.1	35.2	37.4	37.3	33.8	35.5	34.8	37.0	37.5	32.9	34.9	34.4	36.6	37.6
	S.C.	34.3	33.0	27.6	25.5	18.4	33.3	31.0	26.2	24.6	18.0	32.3	29.1	24.7	23.6	17.7
	KW	2.0	2.0	2.0	2.0	2.0	2.0	2.0	2.0	2.0	2.0	1.9	2.0	1.9	2.0	2.0
75	T.C.	33.6	34.7	33.6	35.9	36.6	32.6	33.9	33.2	35.5	36.6	31.5	33.2	32.7	35.1	36.6
	S.C.	33.3	32.5	27.5	25.6	18.6	32.1	30.6	25.8	24.5	18.0	31.0	28.7	24.2	23.3	17.5
	KW	2.2	2.2	2.2	2.2	2.2	2.2	2.2	2.2	2.2	2.2	2.1	2.2	2.2	2.2	2.2
85	T.C.	32.4	33.2	32.0	34.4	35.8	31.3	32.3	31.5	34.1	35.7	30.2	31.5	31.0	33.7	35.5
	S.C.	32.2	32.0	27.3	25.8	18.8	30.9	30.2	25.5	24.3	18.0	29.6	28.3	23.7	22.9	17.3
	KW	2.4	2.4	2.4	2.4	2.4	2.4	2.4	2.4	2.4	2.4	2.3	2.4	2.4	2.4	2.4
95	T.C.	31.3	31.7	30.4	33.0	35.0	30.1	30.7	29.9	35.0	34.8	28.9	29.8	29.4	32.2	34.5
	S.C.	31.1	31.5	27.2	26.0	19.0	29.7	29.7	25.2	24.9	18.0	28.3	27.9	23.2	22.5	17.1
	KW	2.6	2.6	2.6	2.6	2.7	2.6	2.6	2.6	2.6	2.7	2.5	2.6	2.6	2.6	2.6
105	T.C.	27.9	28.8	27.2	29.8	32.5	27.0	27.8	26.6	29.4	32.2	26.0	26.9	25.9	29.0	31.9
	S.C.	28.7	28.9	25.0	25.0	18.4	27.3	27.2	23.2	23.2	17.3	25.8	25.6	21.5	21.4	16.2
	KW	2.8	2.8	2.8	2.8	2.9	2.8	2.8	2.8	2.8	2.9	2.7	2.8	2.7	2.8	2.9
115	T.C.	24.6	26.0	24.2	26.8	30.1	23.9	25.1	23.4	26.3	29.8	23.3	24.1	22.6	25.9	29.5
	S.C.	26.3	26.3	22.8	24.1	17.8	24.9	24.8	21.3	22.2	16.6	23.5	23.3	19.8	20.3	15.4
	KW	3.0	3.0	3.0	3.0	3.1	3.0	3.0	2.9	3.0	3.1	2.9	2.9	2.9	3.0	3.1
125	T.C.	21.3	23.2	21.1	23.7	27.6	20.9	22.3	20.2	23.2	27.3	20.5	21.3	19.3	22.7	27.0
	S.C.	23.9	23.8	20.6	23.2	17.2	22.5	22.4	19.4	21.2	15.9	21.1	21.0	18.2	19.2	14.6
	KW	3.2	3.2	3.2	3.2	3.4	3.2	3.2	3.1	3.2	3.3	3.1	3.1	3.1	3.2	3.3

NOTE: ALL CAPACITIES INCLUDE INDOOR FAN HEAT AT 1250 BTUH/1000 CFM.

Multipliers for determining the performance with other indoor sections.

NOTE: For dry bulb temperatures different than those listed (between 73-87 F), sensible capacity increases by 1060 BTUH per 1000 CFM per degree above the listed temperature and decreases by 1060 BTUH per 1000 CFM per degree below the listed temperature.

Air Handler	Coil	T.C.	S.C.	KW
–	FC/MC/PC43	1.00	1.00	1.00
–	FC/MC/PC48	1.00	1.00	1.00
–	HC42	1.00	1.00	1.00
–	UC48	1.00	1.00	1.00
AHP36	–	1.00	1.00	1.00
AHP42	–	1.00	1.00	1.00
AV36	–	1.01	1.01	0.92
MV16C	FC/MC43C	1.01	1.02	0.92
MA12B	FC/MC43B	1.00	1.00	1.00
MV16C	FC/MC48C	1.01	1.02	0.92
MV20D	FC/MC48D	1.01	1.03	0.92
MA14D	FC/MC48D	1.00	1.00	1.00
MV12D	FC/MC48D	1.01	1.02	0.92
F5FP048	–	1.00	1.00	1.00

Continued on Page 20.

Variable Speed Furnace	Coil	T.C.	S.C.	KW
(F,L)C8V*A12	FC/MC/PC37A	1.00	1.00	0.91
FC9V*A12	FC/MC/PC37A	1.00	1.00	1.00
(F,L)C8V*B16	FC/MC/PC43B	1.01	1.01	0.92
(F,L)C8V*C16	FC/MC/PC43C	1.01	1.02	0.92
(F,L)C8V*C20	FC/MC/PC43C	1.01	1.01	0.92
FC9(C,V)*B12	FC/MC/PC43B	1.00	1.01	0.91
FC9(C,V)*C16	FC/MC/PC43C	1.01	1.01	0.92
FC9(C,V)*C20	FC/MC/PC43C	1.01	1.01	0.92
(F,L)C8V*C16	FC/MC/PC48C	1.01	1.02	0.92
(F,L)C8V*C20	FC/MC/PC48C	1.01	1.01	0.92
FC9(C,V)*C16	FC/MC/PC48C	1.01	1.02	0.92
FC9(C,V)*C20	FC/MC/PC48C	1.01	1.01	0.92
FC9(C,V)*D20	FC/MC/PC48D	1.01	1.02	0.92
(F,L)C8V*C16	HC42	1.01	1.02	0.92
(F,L)C8V*C20	HC42	1.01	1.01	0.92
FC9(C,V)*C16	HC42	1.01	1.01	0.92
FC9(C,V)*C20	HC42	1.01	1.01	0.92
C*(8,L)C*A12	FC/MC/PC37A	0.97	0.93	0.94
C*(8,L)C*B12	FC/MC/PC43B	1.01	1.01	0.98
C*9C*B12	FC/MC/PC43B	1.01	1.01	0.98
C*(8,L)C*C16	FC/MC/PC43C	1.02	1.02	0.94
C*(8,L)C*C20	FC/MC/PC43C	1.02	1.02	0.93
C*9C*C16	FC/MC/PC43C	1.01	1.02	0.97
C*9C*C20	FC/MC/PC43C	1.02	1.02	0.95
C*(8,L)C*C16	FC/MC/PC48C	1.03	1.05	0.94
C*(8,L)C*C20	FC/MC/PC48C	1.03	1.05	0.93
C*9C*C16	FC/MC/PC48C	1.03	1.04	0.95

Variable Speed Furnace	Coil	T.C.	S.C.	KW
C*9C*C20	FC/MC/PC48C	1.03	1.06	0.97
C*9C*D20	FC/MC/PC48D	1.03	1.05	0.94
C*(8,L)C*C16	HC42	1.02	1.02	0.94
C*(8,L)C*C20	HC42	1.02	1.03	0.93
C*9C*C16	HC42	1.01	1.02	0.97
C*9C*C20	HC42	1.02	1.02	0.95
C*(8,L)C*C16	UC48C	0.99	1.00	0.93
C*(8,L)C*C20	UC48C	0.99	1.00	0.92
C*9C*C16	UC48C	0.99	1.00	0.94
C*9C*C20	UC48C	1.00	1.03	0.97
C*9C*D20	UC48D	0.99	1.01	0.94
G*9V*A12	FC/MC/PC37A	0.99	0.97	0.97
G*9V*B12	FC/MC/PC43B	1.01	1.01	0.98
G*9V*C16	FC/MC/PC43C	1.01	1.02	0.97
G*9V*C20	FC/MC/PC43C	1.02	1.02	0.95
G*9V*C16	FC/MC/PC48C	1.03	1.04	0.95
G*9V*C20	FC/MC/PC48C	1.03	1.06	0.97
G*9V*D20	FC/MC/PC48D	1.03	1.05	0.94
G*9V*C16	HC42	1.01	1.02	0.97
G*9V*C20	HC42	1.02	1.02	0.95
G*9V*C16	UC48C	0.99	1.00	0.94
G*9V*C20	UC48C	1.00	1.03	0.97
G*9V*D20	UC48D	0.99	1.01	0.94

COOLING PERFORMANCE DATA																
AIR CONDITIONER MODEL NO.		TCGD42S41S1(H)														
INDOOR COIL MODEL NO.		FC/MC/PC43														
CONDENSING ENTERING AIR TEMPERATURE	IDCFM	1200					1400					1600				
	ID DB (°F)	80	80	75	80	80	80	80	75	80	80	80	80	75	80	80
	ID WB (°F)	57	62	62	67	72	57	62	62	67	72	57	62	62	67	72
65	T.C.	44.4	45.5	43.6	47.0	48.5	45.9	46.5	45.0	48.5	49.8	47.5	47.5	46.5	50.1	51.1
	S.C.	41.5	35.6	29.7	28.7	21.5	42.9	37.5	31.4	30.2	22.9	44.4	39.4	33.2	31.7	24.3
	KW	2.5	2.5	2.5	2.5	2.5	2.5	2.5	2.5	2.5	2.6	2.5	2.5	2.5	2.5	2.6
75	T.C.	42.3	42.9	41.2	45.1	46.6	44.2	44.3	42.7	46.6	47.9	46.0	45.7	44.2	48.1	49.1
	S.C.	39.4	35.2	29.2	28.5	21.3	41.1	37.4	31.1	30.1	22.4	42.9	39.7	33.0	31.8	23.6
	KW	2.7	2.7	2.7	2.8	2.8	2.7	2.7	2.7	2.8	2.8	2.8	2.8	2.8	2.8	2.9
85	T.C.	40.2	40.3	38.9	43.3	44.6	42.4	42.1	40.4	44.7	45.9	44.6	43.9	41.9	46.0	47.2
	S.C.	37.2	34.7	28.7	28.2	21.2	39.3	37.3	30.8	30.0	22.0	41.5	40.0	32.9	31.8	22.9
	KW	3.0	3.0	3.0	3.0	3.1	3.0	3.0	3.0	3.1	3.1	3.0	3.0	3.0	3.1	3.1
95	T.C.	38.2	37.7	36.5	41.5	42.7	40.7	39.9	38.0	42.0	44.0	43.2	42.1	39.6	43.9	45.3
	S.C.	35.0	34.3	28.1	28.0	21.0	37.5	37.3	30.5	29.4	21.6	40.0	40.3	32.8	31.9	22.2
	KW	3.2	3.2	3.2	3.3	3.4	3.3	3.3	3.3	3.3	3.4	3.3	3.3	3.3	3.4	3.4
105	T.C.	35.3	34.7	32.8	37.4	38.7	37.5	36.7	34.2	38.6	39.8	39.8	38.8	35.6	39.8	40.9
	S.C.	32.3	32.1	26.5	26.4	19.6	34.5	34.5	28.8	28.4	20.4	36.7	37.0	31.1	30.5	21.2
	KW	3.5	3.5	3.5	3.6	3.7	3.5	3.5	3.5	3.6	3.7	3.6	3.6	3.5	3.6	3.7
115	T.C.	32.4	31.7	29.2	33.4	34.8	34.5	33.6	30.5	34.6	35.7	36.5	35.5	31.8	35.7	36.7
	S.C.	29.7	30.0	25.0	24.9	18.2	31.6	31.9	27.2	27.0	19.3	33.5	33.8	29.4	29.1	20.3
	KW	3.7	3.7	3.7	3.8	4.0	3.8	3.8	3.7	3.8	4.0	3.8	3.8	3.7	3.9	4.0
125	T.C.	29.6	28.8	25.6	29.4	30.9	31.4	30.5	26.8	30.5	31.7	33.2	32.2	28.0	31.7	32.5
	S.C.	27.1	27.9	23.5	23.4	16.8	28.7	29.3	25.6	25.6	18.1	30.2	30.6	27.6	27.8	19.4
	KW	4.0	4.0	3.9	4.0	4.2	4.0	4.0	4.0	4.1	4.3	4.1	4.1	4.0	4.1	4.3

NOTE: ALL CAPACITIES INCLUDE INDOOR FAN HEAT AT 1250 BTUH/1000 CFM.

Multipliers for determining the performance with other indoor sections.

NOTE: For dry bulb temperatures different than those listed (between 73-87 F), sensible capacity increases by 1060 BTUH per 1000 CFM per degree above the listed temperature and decreases by 1060 BTUH per 1000 CFM per degree below the listed temperature.

Air Handler	Coil	T.C.	S.C.	KW
-	FC/MC/PC48	1.00	1.00	1.00
-	HC42	1.00	1.00	1.00
-	UC48	1.00	1.00	1.00
AHP42	-	0.97	1.00	0.97
MV16C	FC/MC43C	1.00	1.02	0.91
MA16C	FC/MC43C	1.00	1.00	1.00
MV16C	FC/MC48C	1.00	1.02	0.91
MV20D	FC/MC48D	1.00	1.02	0.91
MA14D	FC/MC48D	1.00	1.00	1.00
MA16C	FC/MC48C	1.00	1.00	1.00
F5FP048	-	1.00	1.00	1.00

Variable Speed Furnace	Coil	T.C.	S.C.	KW
(F,L)C8V*B16	FC/MC/PC43B	1.00	1.01	0.91
(F,L)C8V*C20	FC/MC/PC43C	1.00	1.02	0.91
FC9(C,V)*C16	FC/MC/PC43C	1.00	1.01	1.00
FC9(C,V)*C20	FC/MC/PC43C	1.00	1.02	0.91
(F,L)C8V*C16	FC/MC/PC48C	1.00	1.01	0.91
(F,L)C8V*C20	FC/MC/PC48C	1.00	1.02	0.91
FC9(C,V)*C16	FC/MC/PC48C	1.00	1.01	1.00
FC9(C,V)*C20	FC/MC/PC48C	1.00	1.02	0.91
FC9(C,V)*D20	FC/MC/PC48D	1.00	1.02	0.91
(F,L)C8V*C16	HC42	1.00	1.01	0.91
(F,L)C8V*C20	HC42	1.00	1.02	0.91
FC9(C,V)*C16	HC42	1.00	1.01	1.00
FC9(C,V)*C20	HC42	1.00	1.02	0.91
C*(8,L)C*C16	FC/MC/PC43C	1.00	1.01	0.97

Variable Speed Furnace	Coil	T.C.	S.C.	KW
C*(8,L)C*C20	FC/MC/PC43C	1.00	1.02	0.97
C*9C*C16	FC/MC/PC43C	0.99	0.99	0.97
C*9C*C20	FC/MC/PC43C	1.00	1.00	0.97
C*(8,L)C*C16	FC/MC/PC48C	1.00	1.01	0.97
C*(8,L)C*C20	FC/MC/PC48C	1.00	1.01	0.96
C*9C*C16	FC/MC/PC48C	1.00	1.01	0.98
C*9C*C20	FC/MC/PC48C	1.00	1.01	0.98
C*9C*D20	FC/MC/PC48D	1.00	1.01	0.97
C*(8,L)C*C16	HC42	1.00	1.01	0.97
C*(8,L)C*C20	HC42	1.00	1.01	0.97
C*9C*C16	HC42	1.00	1.01	0.98
C*9C*C20	HC42	1.00	1.01	0.97
C*(8,L)C*C16	UC48C	0.99	1.01	0.96
C*(8,L)C*C20	UC48C	0.99	1.01	0.95
C*9C*C16	UC48C	0.99	1.01	0.97
C*9C*C20	UC48C	0.99	1.01	0.97
C*9C*D20	UC48D	0.99	1.01	0.96
G*9V*C16	FC/MC/PC43C	0.99	0.99	0.97
G*9V*C20	FC/MC/PC43C	1.00	1.00	0.97
G*9V*C16	FC/MC/PC48C	1.00	1.01	0.98
G*9V*C20	FC/MC/PC48C	1.00	1.01	0.98
G*9V*D20	FC/MC/PC48D	1.00	1.01	0.97
G*9V*C16	HC42	1.00	1.01	0.98
G*9V*C20	HC42	1.00	1.01	0.97
G*9V*C16	UC48C	0.99	1.01	0.97
G*9V*C20	UC48C	0.99	1.01	0.97
G*9V*D20	UC48D	0.99	1.01	0.96

COOLING PERFORMANCE DATA																
AIR CONDITIONER MODEL NO.		TCGD48S41S1(H)														
INDOOR COIL MODEL NO.		FC/MC/PC48														
CONDENSING ENTERING AIR TEMPERATURE	IDCFM	1400					1600					1800				
	ID DB (°F)	80	80	75	80	80	80	80	75	80	80	80	80	75	80	80
	ID WB (°F)	57	62	62	67	72	57	62	62	67	72	57	62	62	67	72
65	T.C.	49.7	51.4	50.6	55.8	54.6	52.0	53.1	51.9	56.4	55.4	54.4	54.7	53.2	56.9	56.3
	S.C.	47.2	43.1	35.9	36.0	26.1	49.2	45.9	38.2	37.4	27.6	51.2	48.7	40.4	38.8	29.0
	KW	2.7	2.8	2.8	2.8	2.8	2.7	2.8	2.8	2.8	2.8	2.7	2.8	2.8	2.8	2.9
75	T.C.	47.5	48.6	47.7	52.9	52.4	49.8	50.3	48.9	53.6	53.1	52.0	52.1	50.2	54.3	53.8
	S.C.	44.9	42.0	35.0	34.9	25.4	47.0	44.8	37.1	36.5	26.8	49.0	47.6	39.3	38.2	28.1
	KW	3.0	3.0	3.0	3.1	3.1	3.0	3.0	3.0	3.1	3.2	3.0	3.0	3.0	3.1	3.2
85	T.C.	45.4	45.8	44.8	49.9	50.2	47.5	47.6	46.0	50.8	50.8	49.7	49.4	47.1	51.7	51.4
	S.C.	42.7	41.0	34.0	33.8	24.8	44.7	43.7	36.1	35.7	26.0	46.8	46.5	38.2	37.6	27.2
	KW	3.2	3.3	3.3	3.4	3.4	3.3	3.3	3.3	3.4	3.5	3.3	3.3	3.3	3.4	3.5
95	T.C.	43.2	42.9	42.0	47.0	47.9	45.3	44.9	43.1	48.0	48.4	47.4	46.8	44.1	49.1	48.9
	S.C.	40.4	39.9	33.0	32.7	24.1	42.4	42.6	35.1	34.6	25.2	44.5	45.4	37.1	37.0	26.3
	KW	3.5	3.5	3.5	3.6	3.7	3.6	3.6	3.5	3.7	3.8	3.6	3.6	3.6	3.7	3.8
105	T.C.	39.8	39.4	37.3	42.4	43.6	41.6	41.1	38.4	43.4	44.0	43.5	42.9	39.5	44.4	44.5
	S.C.	37.1	37.0	30.9	30.9	22.9	38.9	39.3	32.9	33.0	23.9	40.8	41.5	34.9	35.1	25.0
	KW	3.8	3.8	3.8	3.9	4.0	3.9	3.9	3.8	3.9	4.1	3.9	3.9	3.8	4.0	4.1
115	T.C.	36.5	35.9	32.7	38.0	39.3	38.1	37.5	33.9	38.9	39.8	39.7	39.1	35.1	39.8	40.2
	S.C.	33.9	34.2	28.9	29.2	21.6	35.5	36.0	30.9	31.3	22.7	37.2	37.7	32.8	33.3	23.8
	KW	4.1	4.1	4.0	4.2	4.3	4.1	4.1	4.1	4.2	4.4	4.2	4.2	4.1	4.2	4.4
125	T.C.	33.1	32.4	28.1	33.5	35.1	34.5	33.8	29.4	34.4	35.5	35.9	35.3	30.6	35.2	36.0
	S.C.	30.7	31.4	26.9	27.5	20.4	32.1	32.7	28.8	29.6	21.5	33.5	34.0	30.7	31.6	22.5
	KW	4.4	4.4	4.3	4.4	4.6	4.4	4.4	4.3	4.5	4.7	4.5	4.5	4.4	4.5	4.7

NOTE: ALL CAPACITIES INCLUDE INDOOR FAN HEAT AT 1250 BTUH/1000 CFM.

Multipliers for determining the performance with other indoor sections.

NOTE: For dry bulb temperatures different than those listed (between 73-87 F), sensible capacity increases by 1060 BTUH per 1000 CFM per degree above the listed temperature and decreases by 1060 BTUH per 1000 CFM per degree below the listed temperature.

Air Handler	Coil	T.C.	S.C.	KW
-	FC/MC/PC60	1.00	1.00	1.00
-	HC60	1.00	1.00	1.00
-	UC48	1.00	1.00	1.00
-	UC60	1.00	1.00	1.00
AHP/SHP48	-	1.00	1.00	1.00
AHP/SHP60	-	1.00	1.01	1.00
AV/SV48	-	1.00	1.01	0.91
AV/SV60	-	1.00	1.01	0.91
MV16C	FC/MC48C	1.00	1.01	0.91
MV20D	FC/MC48D	1.00	1.01	0.91
MA16C	FC/MC48C	1.00	1.00	1.00
MA20D	FC/MC48D	1.00	1.00	1.00
MV20D	FC/MC60D	1.00	1.01	0.91
MA16C	FC60C	1.00	1.00	1.00
MA20D	FC/MC60D	1.00	1.00	1.00
F5FP048	-	1.00	1.00	1.00
F5FP060	-	1.00	1.00	1.00
F4FV060	-	1.00	1.01	0.95

Variable Speed Furnace	Coil	T.C.	S.C.	KW
(F,L)C8V*C16	FC/MC/PC48C	0.97	1.00	0.97
(F,L)C8V*C20	FC/MC/PC48C	1.00	1.00	1.00
FC9(C,V)*C16	FC/MC/PC48C	1.00	1.00	1.00
FC9(C,V)*C20	FC/MC/PC48C	1.00	1.00	1.00
FC9(C,V)*D20	FC/MC/PC48D	1.00	1.01	0.91
(F,L)C8V*C16	FC/PC60C	1.00	1.00	1.00
(F,L)C8V*C20	FC/PC60C	1.00	1.00	1.00
FC9(C,V)*C16	FC/PC60C	1.00	1.00	1.00
FC9(C,V)*C20	FC/PC60C	1.00	1.00	1.00
FC9(C,V)*D20	FC/MC/PC60D	1.00	1.01	0.91
C*(8,L)*C16	FC/MC/PC48C	1.00	1.00	0.99
C*(8,L)*C20	FC/MC/PC48C	1.00	1.01	0.99
C*9C*C16	FC/MC/PC48C	1.00	1.00	0.99
C*9C*C20	FC/MC/PC48C	1.00	1.01	0.99
C*9C*D20	FC/MC/PC48D	1.00	1.01	0.99
C*9C*D20	FC/MC/PC60D	1.00	1.01	0.98
C*(8,L)*C16	FC/PC60C	1.00	1.02	0.98
C*(8,L)*C20	FC/PC60C	1.00	1.02	0.96
C*9C*C16	FC/PC60C	1.00	1.02	0.99
C*9C*C20	FC/PC60C	1.00	1.02	0.99
G*9V*C16	FC/MC/PC48C	1.00	1.00	0.99
G*9V*C20	FC/MC/PC48C	1.00	1.01	0.99
G*9V*D20	FC/MC/PC48D	1.00	1.01	0.99
G*9V*D20	FC/MC/PC60D	1.00	1.01	0.98
G*9V*C16	FC/PC60C	1.00	1.02	0.99
G*9V*C20	FC/PC60C	1.00	1.02	0.99

COOLING PERFORMANCE DATA																
AIR CONDITIONER MODEL NO.		TCGD60S41S1														
INDOOR COIL MODEL NO.		FC/MC/PC60														
CONDENSING ENTERING AIR TEMPERATURE	IDCFM	1600					1800					2000				
	ID DB (°F)	80	80	75	80	80	80	80	75	80	80	80	80	75	80	80
	ID WB (°F)	57	62	62	67	72	57	62	62	67	72	57	62	62	67	72
65	T.C.	55.8	63.8	62.1	65.2	71.9	60.3	65.7	62.8	66.7	69.8	64.8	67.5	63.5	68.2	67.8
	S.C.	54.7	51.6	41.4	41.1	34.1	58.4	54.2	43.9	42.6	31.9	62.1	56.8	46.5	44.2	29.6
	KW	3.0	3.0	3.0	3.1	3.1	3.0	3.0	3.0	3.1	3.1	3.0	3.1	3.0	3.1	3.1
75	T.C.	56.9	61.1	58.9	62.7	69.7	59.2	63.0	59.9	64.3	67.9	61.4	64.9	61.0	65.9	66.0
	S.C.	53.9	50.4	40.5	40.0	33.5	55.8	53.1	43.1	41.8	31.5	57.7	55.7	45.6	43.6	29.5
	KW	3.4	3.5	3.5	3.5	3.6	3.4	3.5	3.5	3.5	3.5	3.5	3.5	3.5	3.5	3.5
85	T.C.	58.0	58.4	55.7	60.3	67.6	58.0	60.4	57.1	61.9	65.9	58.1	62.4	58.5	63.6	64.1
	S.C.	53.2	49.3	39.7	39.0	32.9	53.3	52.0	42.2	41.0	31.2	53.4	54.7	44.8	42.9	29.4
	KW	3.9	3.9	3.9	3.9	4.0	3.9	3.9	3.9	3.9	4.0	3.9	3.9	3.9	3.9	4.0
95	T.C.	59.1	55.7	52.5	56.9	65.5	56.9	57.8	54.3	57.0	63.9	54.7	59.8	56.0	61.2	62.2
	S.C.	52.4	48.1	38.8	37.9	32.3	50.7	50.9	41.4	38.8	30.8	49.0	53.6	43.9	42.3	29.4
	KW	4.3	4.3	4.3	4.4	4.5	4.3	4.3	4.3	4.4	4.4	4.3	4.3	4.3	4.4	4.4
105	T.C.	56.4	52.2	48.8	54.0	60.1	54.0	54.3	50.5	55.7	59.7	51.6	56.3	52.2	57.4	59.4
	S.C.	49.7	45.9	37.5	36.5	29.7	47.9	48.3	40.0	38.7	29.4	46.2	50.6	42.5	40.9	29.0
	KW	4.9	4.9	4.9	4.9	5.0	4.9	4.9	4.9	5.0	5.0	4.9	4.9	4.9	5.0	5.0
115	T.C.	53.8	48.8	45.2	50.2	54.8	51.2	50.9	46.8	51.9	55.7	48.7	53.0	48.5	53.6	56.6
	S.C.	47.1	43.8	36.2	35.0	27.3	45.3	45.7	38.6	37.3	27.9	43.5	47.7	41.1	39.6	28.6
	KW	5.5	5.4	5.4	5.5	5.6	5.5	5.5	5.4	5.5	5.6	5.4	5.5	5.4	5.5	5.6
125	T.C.	51.2	45.4	41.6	46.5	49.4	48.5	47.5	43.2	48.2	51.6	45.7	49.7	44.8	49.8	53.8
	S.C.	44.5	41.7	34.9	33.6	24.9	42.6	43.2	37.3	35.9	26.5	40.7	44.7	39.7	38.3	28.2
	KW	6.1	6.0	5.9	6.1	6.2	6.0	6.0	6.0	6.1	6.2	6.0	6.0	6.0	6.1	6.2

NOTE: ALL CAPACITIES INCLUDE INDOOR FAN HEAT AT 1250 BTUH/1000 CFM.

Multipliers for determining the performance with other indoor sections.

NOTE: For dry bulb temperatures different than those listed (between 73-87 F), sensible capacity increases by 1060 BTUH per 1000 CFM per degree above the listed temperature and decreases by 1060 BTUH per 1000 CFM per degree below the listed temperature.

Air Handler	Coil	T.C.	S.C.	KW
-	FC/MC62	1.00	1.00	1.00
-	HC60	1.00	1.00	1.00
-	UC60	1.00	1.00	1.00
AHP/SHP60	-	1.00	1.00	1.00
AV/SV60	-	1.00	1.01	1.00
MV20D	FC/MC60D	1.00	1.01	1.00
MA20D	FC/MC60D	1.00	1.00	1.00
MV20D	FC/MC62D	1.00	1.01	1.00
MA20D	FC/MC62D	1.00	1.00	1.00
F5FP060	-	1.00	1.00	1.00
F4FV060	-	1.00	1.01	1.00

Variable Speed Furnace	Coil	T.C.	S.C.	KW
(F,L)C8V*C20	FC/PC/UC60C	1.00	1.00	1.00
FC9(C,V)*C20	FC/PC/UC60C	1.00	1.00	1.00
FC9(C,V)*D20	FC/MC/PC/UC60D	1.00	1.00	1.00
(F,L)C8V*C20	FC/MC62D	1.00	1.00	1.00
FC9(C,V)*C20	FC/MC62D	1.00	1.00	1.00
FC9(C,V)*D20	FC/MC62D	1.00	1.00	1.00
C*9C*D20	FC/MC/PC60D	0.97	0.95	0.96
C*(8,L)C*C20	FC/MC62D	0.99	0.97	0.94
C*9C*C20	FC/MC62D	0.98	0.96	0.97
C*9C*D20	FC/MC62D	0.99	0.96	0.96
C*(8,L)C*C20	FC/PC60C	0.98	0.96	0.94
C*9C*C20	FC/PC60C	0.97	0.95	0.96
C*9C*D20	HC60	0.94	0.93	0.95
C*(8,L)C*C20	UC60C	0.95	0.91	0.93
C*9C*C20	UC60C	0.94	0.90	0.96
C*9C*D20	UC60D	0.94	0.90	0.95
G*9V*D20	FC/MC/PC60D	0.97	0.95	0.96
G*9V*C20	FC/MC62D	0.98	0.96	0.97
G*9V*D20	FC/MC62D	0.99	0.96	0.96
G*9V*C20	FC/PC60C	0.97	0.95	0.96
G*9V*D20	HC60	0.94	0.93	0.95
G*9V*C20	UC60C	0.94	0.90	0.96
G*9V*D20	UC60D	0.94	0.90	0.95

