

# OIL FURNACES

## UOPF- SERIES DOWNFLOW POSITION



## PREMIUM CLASS DOWNFLOW/ HORIZONTAL OIL FURNACES

Heating Capacities  
87,500 to 134,400 BTU/HR  
[25.64 to 39.39 kW]

The Ruud *Achiever Series*® Premium Class downflow/horizontal oil furnaces provide a variety of airflow arrangements to meet many installation requirements for oil heating. Downflow position is advantageous where ductwork is installed in the slab or crawl space. Horizontal position can be for crawl space, or suspended installations with horizontal airflow.

- Direct drive blower assemblies for heating and air conditioning applications.
- A crimped design stainless steel heat exchanger for efficient and reliable heat transfer.
- Low profile design is lighter, easier to handle, and replaces the old style highboy and lowboy models.
- Removable flue box to easily access and clean secondary heat exchanger.
- Easily field convertible from downflow to horizontal right or horizontal left hand air discharge.
- Blower/motor combinations, cooling coil plenums, return air cabinets, and other air conditioning accessories are available for air conditioning applications.
- Factory tested prior to shipment; each furnace is operated and checked by factory quality control to reduce problems at installation.
- Ruud Achiever oil furnaces offer a wide selection of models and types for almost any installation.
- All oil furnace models are factory assembled with burner mounted ready for downflow operation.
- All models are UL and ULC listed.
- Adjustable solid state fan cycle control.
- Solid-state microprocessor control.
- Indicator light to monitor the burner flame status for improved troubleshooting.
- Clean-cut solenoid controlled oil pump with pre and post purge to prevent oil dripping before and after burn thereby reducing nuisance odors.



## UOPF- SERIES HORIZONTAL POSITION

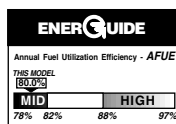

UOPF- Model Shown In Downflow Position (Doors Off)



UOPF- Model Shown In Horizontal Position (Doors Off)

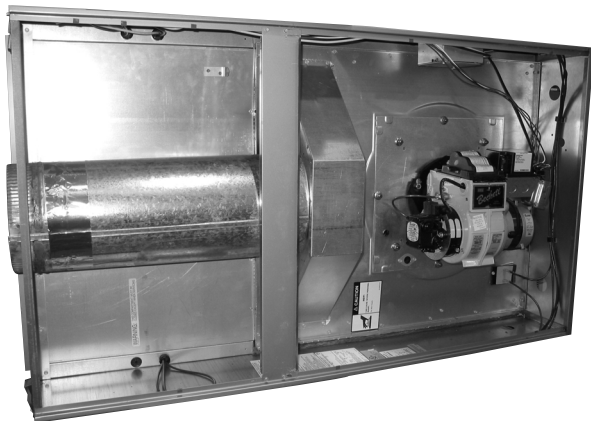

# ACHIEVER SERIES® PREMIUM CLASS DOWNFLOW/ HORIZONTAL OIL FURNACES

## STANDARD EQUIPMENT

Completely assembled and wired; factory set for downflow position; minimum field conversion required; front concealed controls and flue box; pressure atomizing oil burner with single stage fuel pump; continuous duty ignition with lockout feature; removable flue collector box for easy cleaning; direct drive, multi-speed, circulating air blower; limit controls; solid state circulating blower timer; permanent cleanable filters and barometric draft control. All models equipped for cooling with 24V control transformer, blower compartment door safety switch.

**WARNING**  
THIS FURNACE IS NOT APPROVED  
OR RECOMMENDED  
FOR USE IN MOBILE HOMES

## MODEL IDENTIFICATION—DOWNFLOW/HORIZONTAL MODELS

U	O	P	F—	112	Q	B	A	A
Ruud	Oil Furnace	P = Multi-Position Downflow/Horizontal	Design Series	Heating Capacity Output	Blower Designation	Variations B = 1st	Heating & Cooling Designation	Fuel Pump
				Output	Q = 10 x 10 [254 mm x 254 mm]	Variation (All Honeywell Primary Controls)	G—1450-1750 CFM [684-826 L/s]	A—Single Stage (U.S.)
				Output	R = 11 x 10 [279 mm x 254 mm]		J—1800-2075 CFM [850-979 L/s]	C—Single Stage (Canadian)
				BTU/HR				
				Models				
				112				
				130				

**BEFORE PURCHASING THIS APPLIANCE, READ IMPORTANT ENERGY COST AND EFFICIENCY INFORMATION AVAILABLE FROM YOUR RETAILER.**

## **SPECIFICATIONS AND DIMENSIONS—U.S. and Canada**

<b>MODELS</b>	<b>-112</b>			<b>-130</b>
<b>HEATING CAPACITY—BTU/H [kW]</b>	<b>87,500 [25.64]</b>	<b>97,800 [28.66]</b>	<b>113,200 [33.18]</b>	<b>134,400 [39.39]</b>
INPUT-BTU/HR [kW]	105,000 [30.77]	119,000 [34.88]	140,000 [41.03]	168,000 [49.24]
FIRING RATE—GPH [Liters/HR]	.75 [2.8]	.85 [3.2]	1.00 [3.8]	1.20 [4.5]
STD. NOZZLE SIZE	70° x SOLID	70° x SOLID	70° x SOLID	70° x SOLID
BLOWER & MOTOR DRIVE	DIRECT	DIRECT	DIRECT	DIRECT
BLOWER—DIA. x WIDTH [mm]	10 x 10 [254 x 254]	10 x 10 [254 x 254]	10 x 10 [254 x 254]	11 x 10 [279 x 254]
MOTOR H.P. [W] (NO. OF SPEEDS)	1/2 [373] (4)	1/2 [373] (4)	1/2 [373] (4)	3/4 [559] (4)
HEATING SPEED TAP	LOW	MED-LOW	MED-HI	MED-HI
WIDTH [mm]	24 1/2 [622]	24 1/2 [622]	24 1/2 [622]	28 [711]
DEPTH [mm]	28 3/4 [730]	28 3/4 [730]	28 3/4 [730]	28 3/4 [730]
HEIGHT [mm]	46 [1168]	46 [1168]	46 [1168]	49 [1245]
LENGTH OF RETURN CONN. [mm]	20 [508]	20 [508]	20 [508]	20 [508]
WIDTH OF RETURN CONN. (DIM. "B") [mm]	23 [584]	23 [584]	23 [584]	26 1/2 [673]
LENGTH OF SUPPLY CONN. [mm]	19 3/8 [492]	19 3/8 [492]	19 3/8 [492]	19 3/8 [492]
WIDTH OF SUPPLY CONN. (DIM. "E") [mm]	22 [559]	22 [559]	22 [559]	25 1/2 [648]
HEATING EXT. STATIC PRESSURE [kPa]	.2 [.05]	.2 [.05]	.2 [.05]	.2 [.05]
MAX. EXTERNAL STATIC PRESSURE [kPa]	.5 [.12]	.5 [.12]	.5 [.12]	.5 [.12]
TEMPERATURE RISE RANGE °F [°C]	60-90 [33-50]	60-90 [33-50]	60-90 [33-50]	60-90 [33-50]
MOTOR FULL LOAD AMPS	8.7	8.7	8.7	11.0
FLUE SIZE—DIAMETER [mm]	5" [127]	5" [127]	5" [127]	7" [178]
AIR DELIVERY HEATING/COOLING) ③ CFM [L/s]	1007/1339 [475/632]	1348/1493 [636/705]	1436/1493 [678/705]	1642/1854 [775/875]
AIR FILTER SIZE (QTY.) [mm]	(2) 12" x 20" [304 x 508] ②	(2) 12" x 20" [304 x 508] ②	(2) 12" x 20" [304 x 508] ②	(2) 16" x 20" [406 x 508] ②
APPROX. SHIP WT. (LBS.) [kg]	198 [89.8]	198 [89.8]	198 [89.8]	207 [93.8]
AFUE (ISOLATED COMBUSTION) ①	81.6%	81.6%	81.6%	80.5%

① In accordance with D.O.E. test procedures

② Permanent cleanable filter (Rated @ 600 F.P.M. [3 m/s])

③ Heating/cooling C.F.M. @ 0.5" W.C. [0.12 kPa]

[ ] Designates Metric Conversions

# BLOWER PERFORMANCE DATA—DOWNFLOW/HORIZONTAL (U.S. and Canadian)

MODEL NUMBER	HEATING CAPACITY	BLOWER SIZE (IN.) [mm]	MOTOR HP [kW]	BLOWER SPEED	CFM [L/s] AIR DELIVERY E.S.P. INCHES [kPa] WATER COLUMN			
					0.5 [.12]	0.4 [.10]	0.3 [.07]	0.2 [.05]
UOPF-112	87,500	10 x 10 [254 x 254]	1/2 [373]	HIGH +	1493 [705]	1558 [735]	1641 [774]	1676 [791]
				MED-HI*	1436 [678]	1496 [706]	1583 [747]	1634 [771]
				MED-LO	1348 [636]	1408 [665]	1450 [684]	1510 [713]
				LOW	1235 [583]	1274 [601]	1319 [622]	1353 [639]
	97,800	10 x 10 [254 x 254]	1/2 [373]	HIGH +	1493 [705]	1558 [735]	1641 [774]	1676 [791]
				MED-HI	1436 [678]	1496 [706]	1583 [747]	1634 [771]
				MED-LO*	1348 [636]	1408 [665]	1450 [684]	1510 [713]
				LOW	1235 [583]	1274 [601]	1319 [622]	1353 [639]
	113,200	10 x 10 [254 x 254]	1/2 [373]	HIGH +	1493 [705]	1558 [735]	1641 [774]	1676 [791]
				MED-HI*	1436 [678]	1496 [706]	1583 [747]	1634 [771]
				MED-LO	1348 [636]	1408 [665]	1450 [684]	1510 [713]
				LOW	1235 [583]	1274 [601]	1319 [622]	1353 [639]
UOPF-130	134,400	11 x 10 [279 x 254]	3/4 [559]	HIGH +	1854 [875]	1906 [900]	1982 [935]	2002 [945]
				MED-HI*	1642 [775]	1672 [789]	1702 [803]	1731 [817]
				MED-LO	1338 [631]	1357 [640]	1393 [657]	1405 [663]
				LOW	1086 [513]	1128 [532]	1125 [531]	1127 [532]

NOTES: \*HEATING SPEED  
+COOLING SPEED

[ ] Designates Metric Conversions

# DOWNFLOW/HORIZONTAL DIMENSIONS

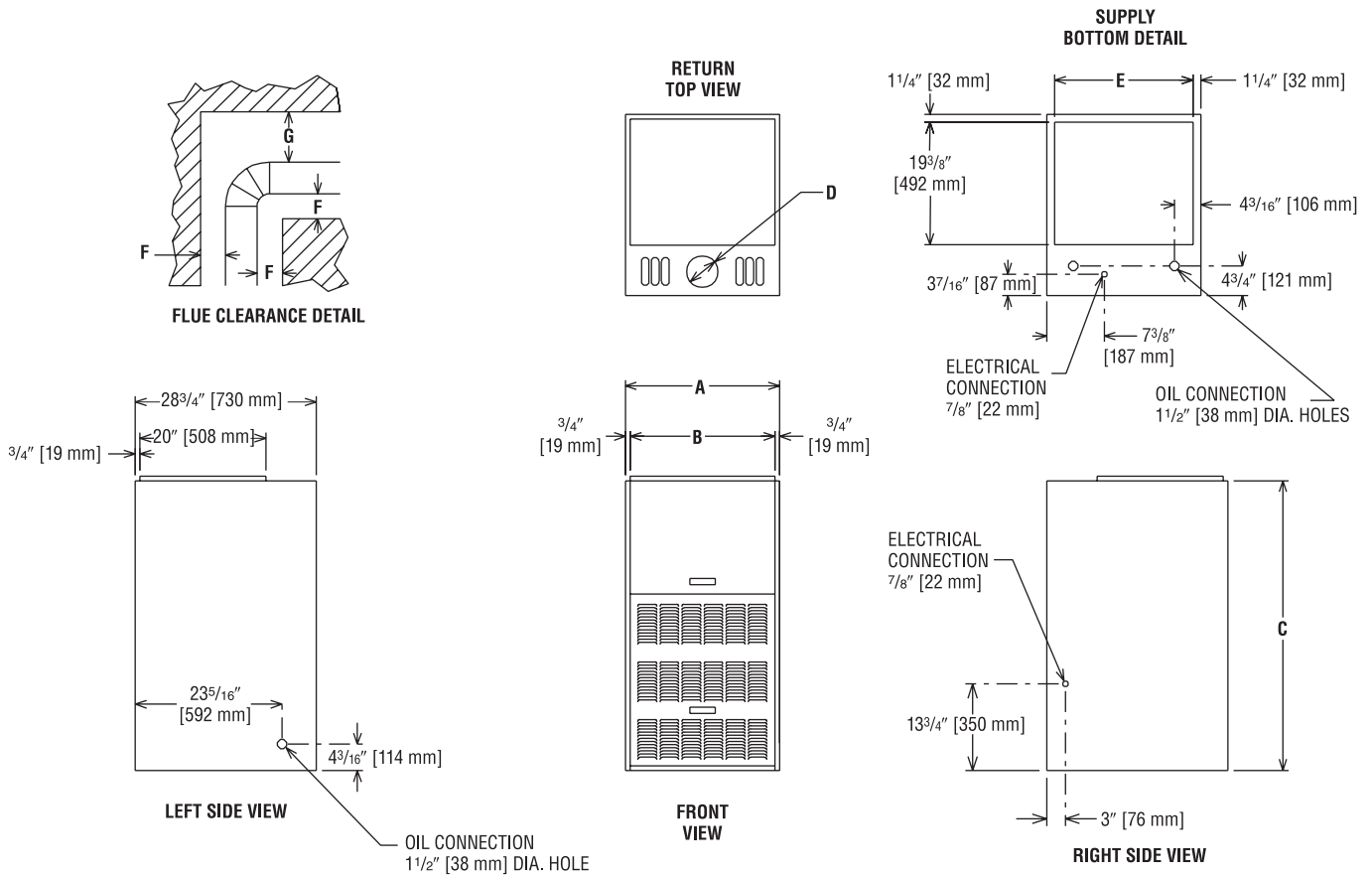

MODEL	DIMENSIONS (IN.) [mm]					DOWNFLOW CLOSET CLEARANCES (IN.) [mm]					HORIZ. ALCOVE CLEARANCES (IN.) [mm]					
	A	B	C	D	E	LEFT SIDE	RIGHT SIDE	BACK	FRONT	TOP	FLUE		FRONT	BACK	TOP	BOTTOM
											F	G				
UOPF-112	24 1/2 [622]	23 [584]	46 [1168]	5 [127]	22 [559]	1 [25]	1 [25]	1 [25]	8 [203]	3 [76]	4 [102]	8 [203]	24 [610]	1 [25]	1 [25]	0
UOPF-130	28 [711]	26 1/2 [673]	49 [1245]	7 [178]	25 1/2 [648]	1 [25]	1 [25]	1 [25]	8 [203]	3 [76]	4 [102]	8 [203]	24 [610]	1 [25]	1 [25]	0

[ ] Designates Metric Conversions

## GENERAL TERMS OF LIMITED WARRANTY

Ruud will furnish a replacement for any part of this product which fails in normal use and service within the applicable period stated here, in accordance with the terms of the limited warranty.

Oil Heat Exchanger.....Limited Lifetime  
Any Other Part.....Five (5) Years

For Complete Details of the Limited Warranty, Including Applicable Terms and Conditions, See Your Local Installer or Contact the Manufacturer for a Copy.

# ACCESSORIES (DOWNFLOW)

**IMPORTANT:** This furnace is certified for use on non-combustible floor. May be installed on combustible flooring **only when equipped with a special factory supplied combustible floor base.**

## PLENUM DATA

Plenum adapters are required in some instances for use on downflow applications when plenum and furnace size do not match.

FURNACE WIDTH (IN.) [mm]	PLENUM WIDTH (IN.) [mm]	PLENUM ADAPTER DOWNFLOW	COIL PLENUM
24½ [622]	24½ [622]	—	RXBD
28 [711]	28 [711]	—	RXBD

## COMBUSTIBLE FLOOR BASE DIMENSIONS\*

COMBUSTIBLE FLOOR BASE	USE WITH MBH INPUT FURNACE SIZES	A (IN.) [mm]	B (IN.) [mm]	C (IN.) [mm]
RXGC-B24	UOPF-112	25 [635]	23¾ [603]	21¾ [553]
RXGC-B28	UOPF-130	28½ [724]	27¼ [692]	25¼ [642]

\*This special base is not required when the furnace is installed on top of an air conditioning plenum.

## FOSSIL FUEL KITS

RXPF-F01—Use for standard heat pump applications.

RXPF-F02—Use for TVA (Tennessee Valley Authority) applications.

## TWINNING KIT

RXOP-D25—For twinning two upflow furnaces.

## FILTER RACK

RXGF-CC—Downflow top return mount.

Note: Filter Racks are shipped without filters. Suitable for 1" [25.4 mm] disposable filters.

## SS1-R SIDEWALL VENT SYSTEM

This furnace is agency approved by CSA for use with the Tjernlund SS1-R Sidewall Vent System (date coded March 2006 or later) when installed in accordance with the installation instructions provided by Tjernlund. Common venting with another appliance is **NOT** an option when using the Tjernlund SS1-R. The use of any other type of power vent system is not approved or recommended by the manufacturer.

## TWO-STAGE PUMP

For applications requiring extra lifts, two-stage fuel pumps are available from PROSTOCK®. The pump must have the clean-cut solenoid, or the primary control will lock out and the heat call will not function.

# COMBUSTIBLE FLOOR BASE

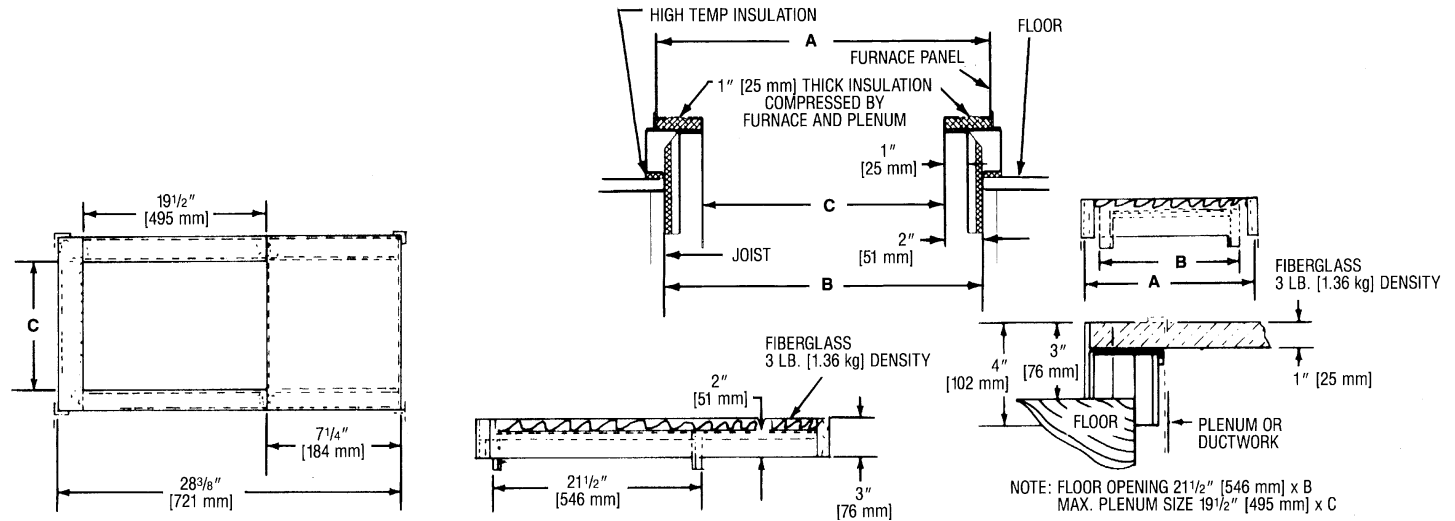

[ ] Designates Metric Conversions

# COIL SELECTION CHART

CASED COIL MODEL NUMBER	DOWNFLOW/HORIZONTAL OIL FURNACE MODEL SIZE HEATING CAPACITY	
	-112	-130
HEATING CAPACITY—BTU/H [kW]	87,500 [25.64] 97,800 [28.66] 113,200 [33.18]	134,400 [39.39]
RCFA-/RCFL-/RCBA-/RCGA-/RCHA-36****21	C	N/A
RCFA-/RCFL-/RCBA-/RCGA-/RCHA-36****24	<b>D</b>	C
RCFA-/RCFL-/RCBA-/RCGA-/RCHA-48****21	C	N/A
RCFA-/RCFL-/RCBA-/RCGA-/RCHA-48****24	<b>D</b>	C
RCFA-/RCFL-/RCBA-/RCGA-/RCHA-60****24	N/A	C
CABINET WIDTH [mm]	24 1/2" [622]	28" [711]

NOTES: \*\*\*\*— Indicates piston size.

C— Require field supplied adapters for transition.

D— Upflow/Downflow/Horizontal Application. Horizontal application requires factory installed horizontal drain pan or field installed horizontal drain pan accessory RXBD-B24.

BOLD TYPE INDICATES FLUSH FIT APPLICATIONS

[ ] Designates Metric Conversions

Before proceeding with installation, refer to installation instructions packaged with each model, as well as complying with all Federal, State, Provincial, and Local codes, regulations, and practices.

**RUUD  
AIR CONDITIONING  
DIVISION**

5600 Old Greenwood Road, Fort Smith, Arkansas 72908



*"In keeping with its policy of continuous progress and product improvement, Ruud reserves the right to make changes without notice."*