

# **MX Series Air Handler Electric or Hot Water Heat Engineering & Specification Guide**

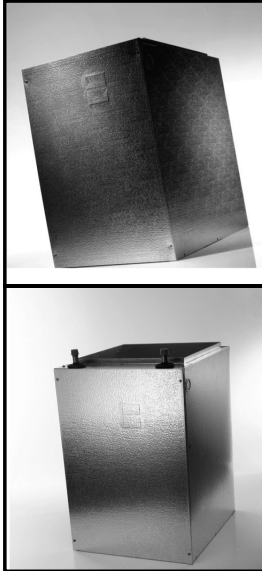

Contents:	Page #:
Standard Features .....	2
Physical Data .....	2
Nomenclature .....	2
Blower Performance .....	3
Dimensions .....	4
Electrical Data.....	5
Hot Water Coil Heating Capacity.....	6

### ! WARNING !

To install the MX Series Air Handler in the horizontal position a (2") clearance must be maintained between the apex of the evaporator coil and the top of the Coil's Cabinet. Therefore, the ADP Multi-position Evaporator Coils listed below cannot be used in the horizontal position with the MX Series Air Handler. The ADP Dedicated Horizontal Coils, HD Series, are recommended for these applications.

- Model #   A 0 7  -----
- Model #   A 1 5  -----
- Model #   E 2 7  -----
- Model #   E 3 7  -----
- Model #   E 4 8  -----
- Model #   E 5 0  -----



**ISO 9001:2000**  
— Registered Quality System —

*Product improvement is a continuous process at Advanced Distributor Products. Therefore, product specifications are subject to change without notice and without obligation on our part. Please contact your ADP representative or distributor to verify detail*

## Standard Features All Models

- Easy Installation: "One-Man-Job"
- Only 20.5" deep and matches most evaporator coils.
- Available from factory as upflow, downflow, and horizontal.
- Only four screws to remove blower panel, making it easier to service.
- Factory installed fan time delay postpones both blower activation and shutoff in heating and cooling modes.
- Embossed cabinet constructed of heavy gauge galvanized steel to prevent corrosion. Lined with high quality 5/8" foil faced insulation.
- Electrical connections can be made on top or right side for 8,12,& 16 size models and top or left side for 20 size models.
- Three-Speed Motor, with easy to adjust settings for fine tuning customer comfort.
- Dynamically balanced blower for quiet, vibration-free operation.

## Standard Features MX Series with Electric Heat

- Slide-out panel with one-point electrical connections.
- Electric Heat kits available for field installation.
- Plug in connections simplify installation of kits.

## Standard Features MX Series with Hot Water Heat

- Suitable for potable water systems.
- Easy to read, plug and play multi-function control board standard on all models. Controls both factory and field installed circulating pumps. Control board includes:

1. Thermostat connections
2. Freeze protection activates circulating pump if water coil temperature drops below 40 deg. F.
3. Pump timer activates circulating pump every six hours for one minute purging the hot water coil of sedentary water. Pump timer activation is skipped while compressor is operating.
4. 24 Vac control to activate an isolation valve supplying hot water to the Air Handler.
5. Auxillary contacts on control board allow the Air Handler to turn on/off a water heater or boiler.
6. Time delay postpones blower activation for one minute after circulating pump turns on to allow hot water coil to reach a sufficient heating temperature.

- Optional factory installed circulating pump fully encased in cabinet.
- Easy to replace hot water coil. Remove one screw and slide out.
- Low water pressure drop through hot water coil for excellent heating performance.
- Water connections 7/8" ODF (for 3/4" water pipe) on 8 & 12 size models and 1 1/8" ODF (for 1" water pipe) on 16 & 20 size models.
- Purge valve on hot water coil allows for manual release of any air trapped in coil during installation or servicing.
- Enhanced grommets - secure & tight.

## Physical Data

		Size			
		8	12	16	20
<b>Nominal CFM</b>		800	1,200	1,600	2,000
<b>Available Voltage*</b>		120 V, 60 Hz, 1 ph. or 208/240 V, 60 Hz, 1 ph.			
<b>Maximum Elec. Heat Kit Allowed for Field Installation (Kw)</b>		10	15	20	20
<b>Transformer Size &amp; Type</b>		40 VA, Class 2			
<b>Blower Wheel (dia." x width")</b>		9 X 6	10 X 8	10 X 8	10 X 10
<b>Electric Heat Blower Data</b>	<b>Motor H. P.</b>	1/4	1/3	1/2	3/4
	<b>F. L. A. @ 240 V</b>	1.9	2.6	4.0	4.3
<b>Hot Water Heat Blower/Pump Data</b>	<b>Blower Motor H. P.</b>	1/3	1/2	1/2	3/4
	<b>Blower F. L. A. @ 120 V</b>	3.2	7.1	7.5	10.5
	<b>Pump Conn. Size</b>	7/8"			
	<b>Pump Voltage</b>	120 V			
	<b>Pump Amps</b>	.52			
<b>Weights Approx. lbs</b>		66	66	71	83

\* No heat only available in 208/240 V, 60 Hz. Hot water heat only available in 120 V, 60 Hz.

## Model Nomenclature

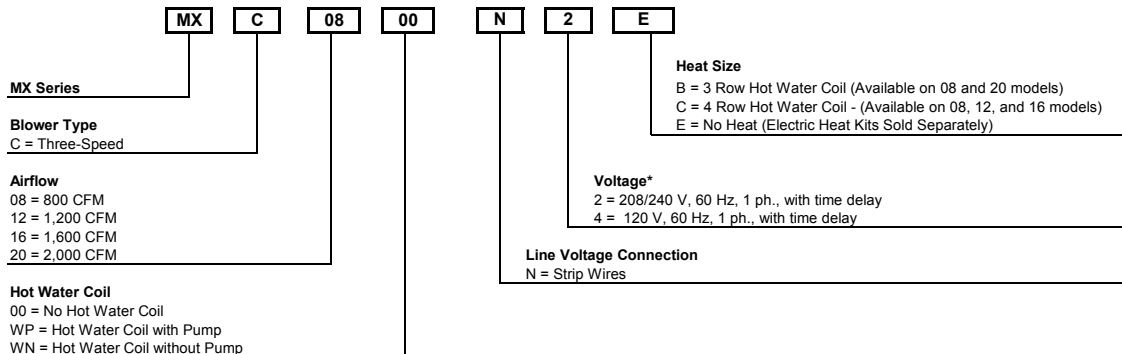

*MX Series w/Electric Heat Blower Performance*

Model Size	Blower Speed	CFM vs. ESP "WC				
		0.1	0.2	0.3	0.4	0.5
08	Low	591	601	586	564	513
	<b>*Med</b>	914	881	832	773	699
	High	1077	1020	947	874	768
12	Low	1085	1076	1059	1043	1009
	<b>*Med</b>	1260	1255	1252	1207	1168
	High	1335	1330	1326	1289	1252
16	Low	1512	1487	1444	1399	1315
	Med	1635	1605	1585	1503	1416
	<b>*High</b>	1732	1703	1635	1555	1471
20	Low	1604	1582	1548	1490	1417
	<b>*Med</b>	2064	1993	1907	1817	1709
	High	2218	2131	2039	1943	1829

*MX Series w/Hot Water Heat Blower Performance*

Model Size	Blower Speed	CFM vs. ESP "WC				
		0.1	0.2	0.3	0.4	0.5
08	Low	749	705	658	614	558
	<b>*Med</b>	865	815	760	708	646
	High	904	836	801	740	681
12	Low	1198	1144	1086	1018	962
	<b>*Med</b>	1257	1198	1130	1072	1010
	High	1273	1215	1158	1094	1018
16	Low	1576	1514	1433	1338	1264
	Med	1643	1576	1490	1407	1320
	<b>*High</b>	1707	1606	1545	1441	1364
20	Low	1759	1691	1652	1580	1512
	Med	1838	1788	1729	1644	1555
	<b>*High</b>	1928	1867	1810	1729	1637

Speeds marked in **bold with an asterisk\*** are the factory speed settings for both heating and cooling.

All data is given while air handler is operating with a dry DX coil and air filter installed.

These are nominal values and blower performance can vary higher or lower from these values based on the evaporator coil that is used.

Hot water heat airflow performance data includes associated air pressure drop across a 4 row hot water coil for Unit Size 08, 12, & 16;

air pressure drop across a 3 row hot water coil for Unit Size 20.

# Dimensions

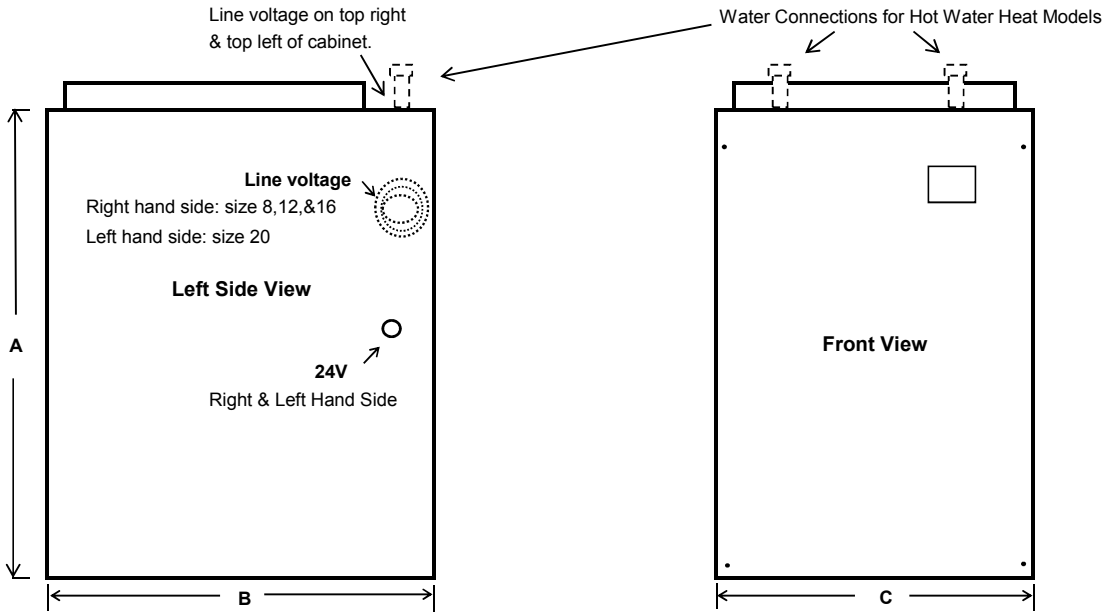

Unit Size	A [in]	B [in]	C [in]	Supply Duct Opening		Return Duct Opening	
				Depth [in]	Width [in]	Depth [in]	Width [in]
<b>8 &amp; 12</b>	27	20 1/2	17 1/2	16	15 1/2	19 1/4	16
<b>16</b>	28	20 1/2	21	16	19	19 1/4	19 1/2
<b>20</b>	28	20 1/2	24 1/2	16	22 1/2	19 1/4	23

*Electrical Data (208/240 V, 60 Hz, 1 ph.)*

Model	Elec. Heating Cap. (1)		Blower Amps	Minimum Circuit Ampacity	Circuit Breaker	
	Kw	BTUH			Amps Per Stage	
Size	240 V	240 V	240 V	240 V	1	2
<b>08 (No Heat)</b>	0	0	1.9	2.4	15	-
<b>08</b>	5	17,065	1.9	28.4	30	-
<b>08</b>	7.5	25,598	1.9	41.4	45	-
<b>08</b>	10	34,130	1.9	54.5	60	-
<b>12 (No Heat)</b>	0	0	2.6	3.3	15	-
<b>12</b>	5	17,065	2.6	29.3	30	-
<b>12</b>	7.5	25,598	2.6	42.3	45	-
<b>12</b>	10	34,130	2.6	55.3	60	-
<b>12</b>	<b>15</b>	51,195	2.6	81.4	60	30
<b>16 (No Heat)</b>	0	0	4.0	5.0	15	-
<b>16</b>	7.5	25,598	4.0	44.1	45	-
<b>16</b>	10	34,130	4.0	57.1	60	-
<b>16</b>	<b>15</b>	51,195	4.0	83.1	60	30
<b>16</b>	<b>20</b>	68,260	4.0	109.2	60	60
<b>20 (No Heat)</b>	0	0	4.3	5.4	15	-
<b>20</b>	7.5	25,598	4.3	44.4	45	-
<b>20</b>	10	34,130	4.3	57.5	60	-
<b>20</b>	<b>15</b>	51,195	4.3	83.5	60	30
<b>20</b>	<b>20</b>	68,260	4.3	109.5	60	60

Kw packages in bold indicates that these heat packages require and include circuit breakers; circuit breakers are optional for all other models.

(1) For 208 Volts use .751 correction factor for Kw & BTUH.

# MX Series with Hot Water Heat: Heating Capacity (BTUH)

## Unit Size 08

Water Coil Size	ENT.	2 GPM				3 GPM			4 GPM		
	WATER	H <sub>2</sub> O P.D.	CFM		H <sub>2</sub> O P.D.	CFM		H <sub>2</sub> O P.D.	CFM		
	TEMP.	in FT.	600	800	in FT.	600	800	in FT.	600	800	
3 ROW	120°F	0.9	17,800	20,200	1.9	19,600	22,700	3.4	20,800	24,600	
	140°F	0.9	25,200	28,500	1.9	27,700	32,000	3.4	29,300	34,700	
	160°F	0.9	32,600	37,000	1.8	35,800	41,400	3.3	37,900	44,900	
	180°F	0.9	40,100	45,500	1.8	44,000	50,900	3.3	46,500	55,100	

Water Coil Size	ENT.	2 GPM				3 GPM			4 GPM				
	WATER	H <sub>2</sub> O P.D.	CFM		H <sub>2</sub> O P.D.	CFM		H <sub>2</sub> O P.D.	CFM				
	TEMP.	in FT.	650	750	800	in FT.	650	750	800	in FT.	650	750	800
4 ROW	120°F	1.6	23,200	25,900	27,600	3.3	25,300	28,400	30,200	5.5	26,700	31,600	33,700
	140°F	1.5	32,300	29,200	31,100	3.2	37,200	37,300	39,700	5.4	39,300	38,100	40,600
	160°F	1.5	39,500	43,300	46,200	3.1	43,100	48,700	51,900	5.2	45,000	51,600	55,100
	180°F	1.4	48,400	53,100	56,700	3.0	52,900	59,700	63,700	5.0	55,100	63,300	67,500

## Unit Size 12

Water Coil Size	ENT.	3 GPM				4 GPM			5 GPM				
	WATER	H <sub>2</sub> O P.D.	CFM		H <sub>2</sub> O P.D.	CFM		H <sub>2</sub> O P.D.	CFM				
	TEMP.	in FT.	1000	1100	1200	in FT.	1000	1100	1200	in FT.	1000	1100	1200
4 ROW	120°F	3.3	33,500	35,000	36,300	5.5	36,200	38,100	39,800	6.9	37,900	40,100	42,000
	140°F	3.2	47,200	49,400	51,300	5.4	51,000	53,700	56,100	6.8	53,500	56,500	59,200
	160°F	3.1	61,100	63,900	66,400	5.2	66,000	69,400	72,500	6.5	69,100	73,000	76,600
	180°F	3.0	75,100	78,600	81,600	5.0	81,000	82,300	89,100	6.3	84,700	89,600	94,000

## Unit Size 16

Water Coil Size	ENT.	3 GPM				4 GPM			5 GPM				
	WATER	H <sub>2</sub> O P.D.	CFM		H <sub>2</sub> O P.D.	CFM		H <sub>2</sub> O P.D.	CFM				
	TEMP.	in FT.	1400	1500	1600	in FT.	1400	1500	1600	in FT.	1400	1500	1600
4 ROW	120°F	1.0	38,600	39,600	40,500	1.7	42,700	44,000	45,200	2.6	45,500	47,000	48,400
	140°F	1.0	54,600	56,000	57,300	1.7	60,300	62,100	63,800	2.6	64,100	66,300	68,300
	160°F	1.0	70,700	72,500	74,200	1.7	78,000	80,400	82,600	2.5	82,900	85,800	88,400
	180°F	1.0	86,900	89,200	91,300	1.6	95,900	98,900	101,600	2.4	101,800	105,300	108,600

## Unit Size 20

Water Coil Size	ENT.	3 GPM				4 GPM			5 GPM				
	WATER	H <sub>2</sub> O P.D.	CFM		H <sub>2</sub> O P.D.	CFM		H <sub>2</sub> O P.D.	CFM				
	TEMP.	in FT.	1800	1900	2000	in FT.	1800	1900	2000	in FT.	1800	1900	2000
3 ROW	120°F	1.1	43,700	44,400	45,100	1.9	49,100	50,100	51,100	2.9	52,900	54,100	55,300
	140°F	1.1	61,700	62,700	63,700	1.9	69,300	70,800	72,100	2.8	74,600	76,400	78,000
	160°F	1.1	79,900	81,200	82,500	1.8	89,700	91,600	93,300	2.8	96,500	78,800	100,900
	180°F	1.1	98,200	99,900	101,400	1.8	110,300	112,600	114,700	2.7	118,600	121,400	124,000

All capacities are based on 70°F entering air temperature.

For entering air temperatures other than 70°F use the following capacity correction factors:

(72°F x .982), (68°F x 1.02), (66°F x 1.04).

Glycol correction factors: (10% X .98), (20% X .95), (30% X .92), (40% X .88)

# Sample Hydronic System Design

Includes: Heating coil selection, line sizing and selected pump other than supplied by ADP

## Sample Application

3 ton Cooling Load  
 180° F Water Temp  
 40% Glycol Mixture  
 80,000 BTUH Heat Required

(1) From the Heating Capacity Tables select the Air Handler that supplies at least 80,000 BTUH at 1,200 CFM, 180° F water temperature.

The Unit Size 12 hot water coil supplies 94,000 BTUH @ 5 GPM, 2.4' pressure drop	94,000
Correct capacity for 40% glycol (correction factors found below capacity chart)	X 0.88
<b>Corrected coil heating capacity (BTUH)</b>	<b>= 82,720</b>

(2) Determine total equivalent line length

Note: Use the following line sizes as a guide for initial selection

1 - 3 GPM, 3/4"	4 - 5 GPM, 1"	6 - 8 GPM, 1 1/4"
-----------------	---------------	-------------------

Line size	1"		Equiv. ft. of pipe (Table 3)			
Total number of fittings	Quantity			=		
90° SR elbows	20	X	2.7'	=	54'	54'
90° LR elbows	0	X	0	=	0	+ 0
45° elbows	0	X	0	=	0	+ 0
gate valves	2	X	1.9'	=	3.8'	+ 3.8'
Total supply and return line length						+ 186'
<b>Total equivalent line length</b>						<b>= 244'</b>

(3) Determine total pump head required

Total equivalent line length	244'	X	Press. Drop/ft (Table 1) 0.015	=	3.66	3.66'
Total pressure drop through coil (found on capacity chart)						+ 2.2'
Line length correction factor for 40% glycol @ 180°F (Table 2)						X 1.12
<b>Total pump head required</b>						<b>6.58'</b>

(4) Now select a pump that supplies 4 GPM with at least 6.58' head capability.

Note: If desired, recalculation can be done with another line size to vary pump requirement.

Nominal Pipe Size	GPM																	
	1	1.25	1.5	1.75	2	2.25	2.5	2.75	3	3.25	3.5	3.75	4	4.5	5	6	7	8
1/2"	.030	.048	.065	.083	.100	.125	.150	.175	.200	-	-	-	-	-	-	-	-	-
3/4"	.005	.009	.012	.016	.019	.024	.029	.034	.039	.045	.050	.056	.062	.077	.092	.130	-	-
1"	-	-	-	-	.005	.006	.007	.008	.009	.011	.012	.014	.015	.019	.023	.033	.042	.053
1 1/4"	-	-	-	-	-	-	-	-	-	-	-	-	.005	.007	.008	.011	.015	.018

% Glycol	140°F	160°F	180°F
10	1.04	1.04	1.02
20	1.08	1.07	1.04
30	1.13	1.11	1.08
40	1.19	1.16	1.12
50	1.24	1.21	1.17

Pipe Size	90° SR el	90° LR el	45° el	gate valve
1/2"	1.5	0.8	1	1
3/4"	2	1	1.4	1.4
1"	2.7	1.3	1.9	1.9
1 1/4"	3.6	1.8	2.5	2.5

## Maximum Line Lengths for Heating Coils Using Factory Installed Circulator

All line lengths are total for supply and return

Model Size	Nominal Pipe Size (ID)	Maximum Supply Pipe Length (ft.) type K copper																		
		GPM																		
		1	1.3	1.5	1.8	2	2.3	2.5	2.8	3	3.3	3.5	3.8	4	4.3	4.5	4.8	5	6	7
8	1/2"	256	148	98	70	51	33	20	12	5	-	-	-	-	-	-	-	-	-	-
	3/4"	-	-	-	454	351	251	186	140	105	-	-	-	-	-	-	-	-	-	-
12	3/4"	-	-	-	-	-	-	-	-	126	97	75	57	43	30	19	11	4	-	-
	1"	-	-	-	-	-	-	-	-	-	497	397	319	257	200	156	120	90	-	-
	1 1/4"	-	-	-	-	-	-	-	-	-	-	-	-	-	-	514	405	315	-	-
16	3/4"	-	-	-	-	-	-	-	-	126	97	75	57	43	30	19	11	4	-	-
	1"	-	-	-	-	-	-	-	-	-	497	397	319	257	200	156	120	90	-	-
	1 1/4"	-	-	-	-	-	-	-	-	-	-	-	-	-	-	514	405	315	-	-
20	3/4"	-	-	-	-	-	-	-	-	123	94	72	54	40	27	16	8	-	-	-
	1"	-	-	-	-	-	-	-	-	-	485	382	306	244	187	143	106	77	-	-
	1 1/4"	-	-	-	-	-	-	-	-	-	-	-	-	-	-	476	367	278	-	-

**Notes:**

- Line lengths are based on water only. To adjust maximum line lengths for glycol, divide length by the factors shown in **Table 2**.
- IMPORTANT:** Glycol should never be used in a potable water system.
- All lengths are based on closed loop systems.
- Line lengths within the shaded areas should not be used when a water heater is the source of heat. For these line lengths, excessive line temperature loss will occur and must be accounted for.
- Supply and return lines must be properly insulated to reduce temperature loss and to prevent freezing when passing through an unconditioned space.
- All lengths include (12) 90° short radius elbows. To adjust for extra or fewer fittings, use the factors in **Table 1**.
- Always use full flow ball or gate valves to minimize pressure drop.

Pipe size	90° SR el	90° LR el	45° el	gate valve
1/2"	1.5	0.8	1	1
3/4"	2	1	1.4	1.4
1"	2.7	1.3	1.9	1.9
1 1/4"	3.6	1.8	2.5	2.5

% Glycol	140° F	160° F	180° F
10	1.04	1.04	1.02
20	1.08	1.07	1.04
30	1.13	1.11	1.08
40	1.19	1.16	1.12
50	1.24	1.21	1.17



Advanced Distributor Products

2175 West Park Place Boulevard  
 Stone Mountain, Georgia 30087  
 www.adpnw.com  
 adp.feedback@adpnw.com