

TECHNICAL GUIDE

MODELS: MV

MODULAR VARIABLE SPEED AIR HANDLERS FOR USE WITH SPLIT SYSTEM COOLING & HEAT PUMP

1200 - 2000 CFM BLOWERS

3 - 5 TON COILS

OPTIONAL 1 & 3 ϕ ELECTRIC HEATERS

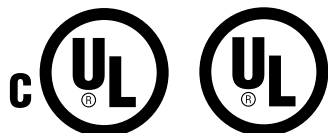

Due to continuous product improvement, specifications subject to change without notice.

Visit us on the web at www.york.com

Additional rating information can be found at www.ari.org/aridirectory

DESCRIPTION

This unique modular system allows the flexibility to handle any application. These versatile coils and blowers may be used for upflow, downflow, or horizontal left or right applications. They may be combined to function as a cooling only unit or with a heat pump including electric heat for 1 and 3 phase applications. The blower and electric heater could be used as stand alone electric furnaces.

FEATURES

BLOWERS - Models to match any air flow or voltage requirement. The compact size allows easy installation. Blowers are sized to deliver design air quantity both efficiently and quietly. The motors provide a selection of air quantities to match any application. All models include a one-minute blower off delay as standard to enhance system efficiency ratings. The durable, pre-painted steel protects the unit against rust and corrosion. All models have 1 inch foil face fiber glass insulation, providing a thermal insulation value of R-4.2.

COILS - Staggered rows of rifled copper tubes are mechanically expanded into enhanced surface aluminum fins to provide high heat transfer and long-lasting quality. The MC multi-position coils may be used for upflow, downflow, and horizontal left or right applications. Coil cabinets are insulated with 3/4" foil face insulation to prevent sweating.

ELECTRIC HEATERS - Both single and three phase electric heater models are available to match any requirement. All heaters include nickel-chromium elements with a 5-year limited warranty on 1 \emptyset heating elements and 1 year limited warranty on 3 \emptyset heating elements. Sequential operation is provided to control heaters in all models. Circuit breakers are used in 208/230 volt, single-phase heaters of 15 KW and larger.

Models equipped with circuit breakers may be altered in the field to use multi-source power supply. Over-temperature limit switches provide protection from airflow loss with fusible link backup protection.

ACCESSORIES - A full line of matching accessories available for use with the blower and coils to allow any type application.

LIMITATIONS - These units must be wired and installed in accordance with all national and local safety codes.

Voltage limits are as follows:

AIR HANDLER VOLTAGE	NORMAL OPERATING VOLTAGE RANGE*
208/230-1-60	187 - 253

* Rated in accordance with ARI Standard 110, utilization range "A".

Air flow must be within the minimum and maximum limits approved for electric heat, evaporator coils and outdoor units.

DIMENSIONS - (BLOWER WITH MC COILS)

NOTE: Power wiring may be brought into the unit through one of the knockouts in either the top or the left side panel. Multiple knockouts are provided to accommodate all of the electric heat and transformer accessories that are available. Use the knockouts that provide the best wire routing for the accessory being used.

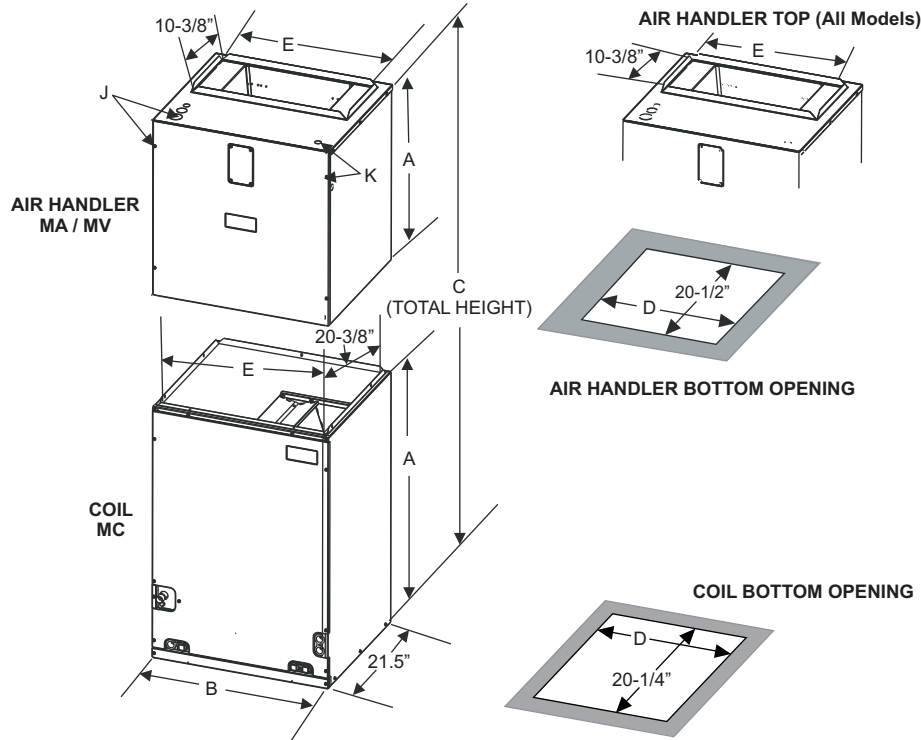

DIMENSIONS

Model	Dimensions					Wiring K.O.'s ¹		Refrigerant Connections	
	A	B	C	D	E	J	K	Line Size	
	Height	Width	Total Height					Power	Control
MV12B	25	17-1/2	47 to 57 Depending on combination.	16-1/2	14-19/32	7/8" (1/2") 1-3/8" (1") 1-23/32" (1-1/4")	7/8" (1/2")	-	-
MV12D	25	24-1/2		23-1/2	21-19/32			-	-
MV16C	25	21		20	18-3/32			-	-
MV20D	25	24-1/2		23-1/2	21-19/32			-	-
MC24B**H	26-1/2	17-1/2		16-1/2	16-3/8	-	-	3/8	3/4
MC30B**H	26-1/2	17-1/2		16-1/2	16-3/8	-	-		
MC35B**H	22	17-1/2		16-1/2	16-3/8	-	-		
MC35C**H	26-1/2	21		20	19-7/8	-	-		
MC36B**H	26-1/2	17-1/2		16-1/2	16-3/8	-	-		
MC36C**H	26-1/2	21		20	19-7/8	-	-		
MC42B**H	32	17-1/2		16-1/2	16-3/8	-	-		
MC42C**H	32	21		20	19-7/8	-	-		
MC48C**H	32	21		20	19-7/8	-	-		
MC48D**H	32	24-1/2		23-1/2	23-3/8	-	-		
MC60D**H	32	24-1/2		23-1/2	23-3/8	-	-		
MC61D**H	36	24-1/2		61	23-1/2	23-3/8	-		-

1. Parenthesis indicate conduit size

COOLING CAPACITY - COIL ONLY

Blower Model	Coil Model	Rated CFM	Entering Air °F (Dry / Wet Bulb)	MBH @ Evaporator Temperature and Corresponding Pressure °F / PSIG			
				35 / 61.5	40 / 68.5	45 / 76.0	50 / 84.0
Multi-Position - Upflow / Downflow / Horizontal							
MV12B	MC30B**H	1025	85 / 72	41.5	37.8	33.7	29.5
			80 / 67	36.2	32.4	28.6	24.5
			75 / 62	29.1	25.3	24.0	19.2
			70 / 57	24.1	21.5	18.7	15.8
	MC36B**H	1250	85 / 72	52.0	47.3	42.3	37.3
			80 / 67	41.7	36.8	32.3	27.4
			75 / 62	32.5	27.3	29.8	22.2
			70 / 57	27.9	25.8	23.8	22.2
MV12D	MC48D**H	1125	85 / 72	46.8	42.4	37.6	33.0
			80 / 67	37.4	33.3	29.4	24.3
			75 / 62	28.9	24.6	21.7	19.6
			70 / 57	25.1	23.3	21.7	19.6
	MC60D**H	1275	85 / 72	53.7	48.4	43.5	37.5
			80 / 67	43.0	38.0	33.3	27.7
			75 / 62	33.1	28.1	24.5	22.4
			70 / 57	28.8	26.5	24.5	22.4
	MC61D**H	1450	85 / 72	91.7	78.4	68.1	52.3
			80 / 67	73.4	61.5	52.0	38.6
			75 / 62	57.3	45.6	38.4	31.2
			70 / 57	49.2	43.0	38.4	31.2
MV16C	MC42C**H	1400	85 / 72	88.4	76.0	63.3	50.0
			80 / 67	70.8	59.4	48.4	37.0
			75 / 62	55.2	43.9	35.8	29.9
			70 / 57	47.4	41.5	35.8	29.9
	MC48C**H	1650	85 / 72	100.5	86.4	72.0	56.8
			80 / 67	80.4	67.5	55.0	42.1
			75 / 62	62.7	49.9	40.7	34.0
			70 / 57	53.9	47.2	40.7	34.0
MV20D	MC48D**H	1725	85 / 72	119.9	101.0	80.0	62.2
			80 / 67	96.0	79.2	62.6	45.8
			75 / 62	74.0	58.6	46.2	37.0
			70 / 57	64.3	55.4	46.2	37
	MC60D**H	2000	85 / 72	124.8	105.2	85.3	64.7
			80 / 67	99.9	82.5	65.2	47.7
			75 / 62	77	61.1	48.1	38.6
			70 / 57	66.9	57.7	48.1	38.6
	MC61D**H	2200	85 / 72	131.0	110.5	89.6	67.9
			80 / 67	104.9	86.6	68.5	50.1
			75 / 62	81.8	64.2	50.5	40.5
			70 / 57	70.2	60.6	50.5	40.5

PHYSICAL & ELECTRICAL DATA

Model		MV12BN21	MV12DN21	MV16CN21	MV20DN21
Blower - Diameter x Width		10 x 7	10 x 10	10 x 10	10 x 10
Motor	HP	1/2	1/2	3/4	1
	Nominal RPM	1200	1200	1200	1200
Voltage		208/230			
Amps	Full Load (230)	4.3	4.3	5.0	7.0
Permanent Filter ¹	Type	DISPOSABLE OR PERMANENT			
	Size	16 x 20 x 1	24 x 20 x 1	20 x 20 x 1	24 x 20 x 1
	Filter Bulk Kit	1PF0601BK	1PF0604BK	1PF0602BK	1PF0604BK
Shipping / Operating Weight (lbs.)		75 / 71	88 / 82	88 / 82	94 / 88

1. Field Supplied

COILS

Model	Application	Refrig. Conn. Types	Face Area (Sq. Ft.)	Rows Deep	Fin Per In.	Coil Size	Tube Geometry	Tube Dia.	Fin Type	TXV	Operating Weight (Lbs.)
MC18A3XH1	Cooling / Heat Pump	Sweat	3.40	2	14	(2) 14 x 17.5	1 x 0.866	3/8	Enhanced	None	53
MC18A2AH1										2A	
MC18B3XH1			3.40	2	14	(2) 14 x 17.5				None	53
MC18B2AH1										2A	
MC24A3XH1			4.38	2	14	(2) 18 x 17.5				None	56
MC24A2AH1										2A	
MC24B3XH1			4.38	2	14	(2) 18 x 17.5				None	56
MC24B2AH1										2A	
MC30A3XH1			4.38	2	14	(2) 18 x 17.5				None	56
MC30A2AH1										2A	
MC30B3XH1			4.38	2	14	(2) 18 x 17.5				None	56
MC30B2AH1										2A	
MC35B3XH1			3.90	3	12	(2) 16 x 17.5				None	65
MC35C3XH1										None	
MC36A3XH1			4.86	2	14	(2) 20 x 17.5				None	64
MC36A2AH1										2A	
MC36B3XH1			4.86	2	14	(2) 20 x 17.5				None	65
MC36B2AH1										2A	
MC36C3XH1			4.86	2	14	(2) 20 x 17.5				None	65
MC36C2AH1										2A	
MC42B3XH1			5.83	2	14	(2) 24 x 17.5				None	72
MC42B2CH1										2C	
MC42C3XH1			5.83	2	14	(2) 24 x 17.5				None	72
MC42C2CH1										2C	
MC48C3XH1			5.35	3	12	(2) 22 x 17.5				None	82
MC48C2CH1										2C	
MC48D3XH1			5.35	3	12	(2) 22 x 17.5				None	82
MC48D2CH1										2C	
MC60D3XH1			5.83	3	12	(2) 24 x 17.5				None	86
MC60D2CH1										2C	
MC61D3XH1			6.80	3	12	(2) 28 x 17.5				None	98
MC61D2CH1										2C	

ELECTRICAL DATA - 208/230-1-60

Model	Heater Model*	Max. Static	Min. Speed Tap	Total Heat ¹				KW Staging					
				KW		MBH		W1 Only		W2 Only		W1 + W2	
				208V	240V	208V	240V	208V	240V	208V	240V	208V	240V
MV12B	4HK*6500506	0.5	Heat-D	3.6	4.8	12.3	16.4	3.6	4.8	3.6	4.8	3.6	4.8
	4HK*6500806	0.5	Heat-D	5.6	7.5	19.2	25.6	2.8	3.75	5.6	7.5	5.6	7.5
	4HK*6501006	0.5	Heat-D	7.2	9.6	24.6	32.8	3.6	4.8	7.2	9.6	7.2	9.6
	4HK165N1506	0.5	Heat-D	10.8	14.4	36.9	49.1	3.6	4.8	7.2	9.6	10.8	14.4
MV12D	4HK*6500506	0.5	Heat-D	3.6	4.8	12.3	16.4	3.6	4.8	3.6	4.8	3.6	4.8
	4HK*6500806	0.5	Heat-D	5.6	7.5	19.2	25.6	2.8	3.75	5.6	7.5	5.6	7.5
	4HK*6501006	0.5	Heat-D	7.2	9.6	24.6	32.8	3.6	4.8	7.2	9.6	7.2	9.6
	4HK16501506	0.5	Heat-D	10.8	14.4	36.9	49.1	3.6	4.8	7.2	9.6	10.8	14.4
	4HK16501806	0.5	Heat-D	13.2	17.6	45.1	60.1	3.3	4.4	6.6	8.8	13.2	17.6
	4HK16502006	0.5	Heat-D	14.4	19.2	49.2	65.5	3.6	4.8	7.2	9.6	14.4	19.2
MV16C	4HK*6500506	0.5	Heat-D	3.6	4.8	12.3	16.4	3.6	4.8	3.6	4.8	3.6	4.8
	4HK*6500806	0.5	Heat-D	5.6	7.5	19.2	25.6	2.8	3.75	5.6	7.5	5.6	7.5
	4HK*6501006	0.5	Heat-D	7.2	9.6	24.6	32.8	3.6	4.8	7.2	9.6	7.2	9.6
	4HK16501506	0.5	Heat-D	10.8	14.4	36.9	49.1	3.6	4.8	7.2	9.6	10.8	14.4
	4HK16501806	0.5	Heat-D	13.2	17.6	45.1	60.1	3.3	4.4	6.6	8.8	13.2	17.6
	4HK16502006	0.5	Heat-D	14.4	19.2	49.2	65.5	3.6	4.8	7.2	9.6	14.4	19.2
MV20D	4HK*6501006	0.5	Heat-D	7.2	9.6	24.6	32.8	3.6	4.8	7.2	9.6	7.2	9.6
	4HK16501506	0.5	Heat-D	10.8	14.4	36.9	49.1	3.6	4.8	7.2	9.6	10.8	14.4
	4HK16501806	0.5	Heat-D	13.2	17.6	45.1	60.1	3.3	4.4	6.6	8.8	13.2	17.6
	4HK16502006	0.5	Heat-D	14.4	19.2	49.2	65.5	3.6	4.8	7.2	9.6	14.4	19.2
	4HK16502506	0.5	Heat-D	18.0	24.0	61.5	81.9	3.6	4.8	10.8	14.4	18.0	24

1. See conversion table on Page 7.

* May be 0 (no breaker) or 1 (with breaker).

ELECTRICAL DATA - 208/230-3-60

Models	Heat Kit - Three Phase	Max. Static	Min. Speed Tap	Total Heat ¹				KW Staging					
				KW		MBH		W1 Only		W2 Only		W1 + W2	
				208V	240V	208V	240V	208V	240V	208V	240V	208V	240V
MV12BN21	4HK06501025	0.5	Heat-D	7.2	9.6	24.6	32.8	7.2	9.6	7.2	9.6	7.2	9.6
MV12DN21	4HK06501025	0.5	Heat-D	7.2	9.6	24.6	32.8	7.2	9.6	7.2	9.6	7.2	9.6
	4HK06501525	0.5	Heat-D	10.8	14.4	36.9	49.1	10.8	14.4	10.8	14.4	10.8	14.4
MV16CN21	4HK06501825	0.5	Heat-D	12.9	17.2	44.7	58.7	12.9	17.2	12.9	17.2	12.9	17.2
	4HK06501025	0.5	Heat-D	7.2	9.6	24.6	32.8	7.2	9.6	7.2	9.6	7.2	9.6
	4HK06501525	0.5	Heat-D	10.8	14.4	36.9	49.1	10.8	14.4	10.8	14.4	10.8	14.4
MV20DN21	4HK06501825	0.5	Heat-D	12.9	17.2	44.7	58.7	12.9	17.2	12.9	17.2	12.9	17.2
	4HK06501025	0.5	Heat-D	7.2	9.6	24.6	32.8	7.2	9.6	7.2	9.6	7.2	9.6
	4HK06501525	0.5	Heat-D	10.8	14.4	36.9	49.1	10.8	14.4	10.8	14.4	10.8	14.4
	4HK16502525	0.5	Heat-D	18.0	24.0	61.4	81.4	9.0	12.0	18.0	24.0	18.0	24.0

1. See conversion table on Page 7.

ELECTRICAL DATA (FOR SINGLE SOURCE POWER SUPPLY) - COPPER WIRE 208/230-1-60

Model	Heater Model ^{1,*}	Field Wiring							
		Heater Amps	Ampacity Min. Circuit			Max. O.C.P. ² Amps/Type		Wire Size - AWG 75°C	
			240V	208V	240V	208V	240V	208V	240V
MV12B	4HK*6500506	20.0	27.54	30.38	30	35	10	8	
	4HK*6500806	31.3	39.73	44.50	40	45	8	8	
	4HK*6501006	40.0	49.21	55.38	50	60	8	6	
	4HK165N1506	60.0	70.88	80.38	90	90	4	3	
MV12D	4HK*6500506	20.0	27.54	30.38	30	35	10	8	
	4HK*6500806	31.3	39.73	44.50	40	45	8	8	
	4HK*6501006	40.0	49.21	55.38	50	60	8	6	
	4HK16501506	60.0	70.88	80.38	90	90	4	3	
	4HK16501806	73.3	85.32	97.00	90	100	4	3	
	4HK16502006	80.0	92.54	105.38	100	125	3	1	
MV16C	4HK*6500506	20.0	29.29	31.88	30	35	10	8	
	4HK*6500806	31.3	41.48	46.00	45	50	8	8	
	4HK*6501006	40.0	50.96	56.88	60	60	6	6	
	4HK16501506	60.0	72.63	81.88	90	90	3	3	
	4HK16501806	73.3	87.07	98.50	90	100	3	2	
	4HK16502006	80.0	94.29	106.88	100	125	3	1	
MV20D	4HK*6501006	40.0	53.08	58.75	60	60	6	6	
	4HK16501506	60.0	74.75	83.75	90	90	3	3	
	4HK16501806	73.3	89.19	100.38	90	110	3	2	
	4HK16502006	80.0	96.42	108.75	100	125	3	1	
	4HK16502506	100.0	118.08	133.75	125	150	1	1/0	

1. 30 KW 3 phase not approved for single source power supply.

2. OCP = Over Current Protection device, must be HACR type Circuit Breaker or Time Delay fuse.

* May be 0 (no breaker) or 1 (with breaker).

ELECTRICAL DATA (FOR SINGLE SOURCE POWER SUPPLY) - COPPER WIRE 208/230-3-60

Models	Heat Kit - Three Phase	Heater Amps 240V	Field Wiring					
			Min. Circuit Ampacity		Max. O.C.P. ¹ Amps/Type		75°C Wire Size - AWG	
			208V	240V	208V	240V	208V	240V
12B	4HK06501025	23.1	30.9	34.3	35	35	8	8
12D	4HK06501025	23.1	30.9	34.3	35	35	8	8
	4HK06501525	34.7	43.4	48.8	45	50	8	8
	4HK06501825	41.4	50.6	57.1	50	60	8	6
16C	4HK06501025	23.1	32.6	35.1	35	35	8	8
	4HK06501525	34.7	45.1	49.6	45	50	8	8
	4HK06501825	41.4	52.4	58.0	60	60	6	6
20D	4HK06501025	23.1	34.8	37.6	35	40	8	8
	4HK06501525	34.7	47.3	52.1	50	60	8	6

1. O.C.P. = Over Current Protection device, must be HACR type Circuit Breaker or Time Delay fuse.

TABLE 1: Electrical Data - (For **Multi-Source** Power Supply) - Copper Wire - 208/230-3-60

Models	Heater Model	Minimum Circuit Ampacity			Max. O.C.P. ¹ Amps/Type			75°C Wire Size - AWG		
		Circuit								
		1st	2nd	3rd	1st	2nd	3rd	1st	2nd	3rd
		208/240	208/240	208/240	208/240	208/240	208/240	208/240	208/240	208/240
20D	4HK16502525	41.0 / 44.9	31.3 / 36.1	- / -	45 / 45	35 / 40	- / -	8 / 8	8 / 8	- / -

1. O.C.P. = Over Current Protection device, must be HACR type Circuit Breaker or Time Delay fuse.

ELECTRICAL DATA (FOR MULTI SOURCE POWER SUPPLY) - COPPER WIRE 208/230-1-60

Model	Heater Model	Min. Circuit Ampacity			Max. O.C.P. ¹ Amps/Type			75°C Wire Size - AWG		
		Circuit			Circuit			Circuit		
		1st	2nd	3rd	1st	2nd	3rd	1st	2nd	3rd
		208/240	208/240	208/240	208/240	208/240	208/240	208/240	208/240	208/240
MV12B	4HK165N1506	49.2 / 55.4	21.7 / 25.0	–	50 / 60	25 / 25	–	8 / 6	10 / 10	–
MV12D	4HK16501506	49.2 / 55.4	21.7 / 25.0	–	50 / 60	25 / 25	–	8 / 6	10 / 10	–
	4HK16501806	45.6 / 51.2	39.7 / 45.8	–	50 / 60	40 / 50	–	8 / 6	8 / 8	–
	4HK16502006	49.2 / 55.4	43.3 / 50.0	–	50 / 60	45 / 50	–	8 / 6	8 / 8	–
MV16C	4HK16501506	51.0 / 56.9	21.7 / 25.0	–	50 / 60	25 / 25	–	8 / 6	10 / 10	–
	4HK16501806	17.3 / 52.7	39.7 / 45.8	–	50 / 60	40 / 50	–	8 / 6	8 / 8	–
	4HK16502006	51.0 / 56.9	43.3 / 50.0	–	50 / 60	45 / 50	–	8 / 6	8 / 8	–
MV20D	4HK16501506	53.1 / 58.8	21.7 / 25.0	–	60 / 60	25 / 25	–	6 / 6	10 / 10	–
	4HK16501806	49.5 / 54.6	39.7 / 45.8	–	50 / 60	40 / 50	–	8 / 6	8 / 8	–
	4HK16502006	53.1 / 58.8	43.3 / 50.0	–	60 / 60	45 / 50	–	6 / 6	8 / 8	–
	4HK16502506	49.3 / 56.5	43.3 / 50.0	21.7 / 25.0	50 / 60	45 / 50	25 / 25	8 / 6	8 / 8	10 / 10

1. OCP = Over Current Protection device, must be HACR type Circuit Breaker or Time Delay fuse.

KW & MBH CONVERSIONS

FOR	208-VOLT	OPERATION MULTIPLY	240-VOLT	TABULATED KW & MBH BY	.751
	230-VOLT		240-VOLT		.918

ELECTRICAL DATA - COOLING UNIT ONLY (60 Hz)

MODEL	Total Motor Amps		Minimum Circuit Ampacity		Max. O.C.P. ¹ Amps/Type	Minimum Wire Size AWG @ 75°C
	60 Hertz		60 Hertz			
	208V	230V	208V	230V		
MV12B	4.7	4.3	5.9	5.4	15	14
MV12D	4.7	4.3	5.9	5.4	15	14
MV16C	6.1	5.0	7.6	6.9	15	14
MV20D	7.8	7.0	9.7	8.8	15	14

1. OCP = Over Current Protection device, must be HACR type Circuit Breaker or Time Delay fuse.

POWER WIRING

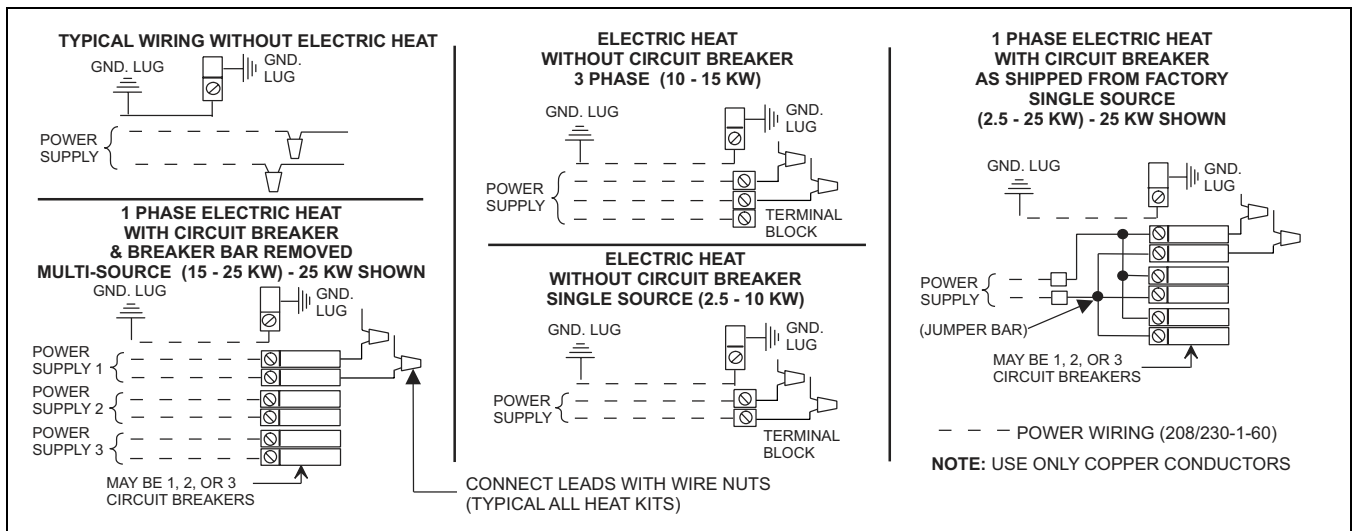

Line Power

ACCESSORIES

Refer to Price Manual for specific model numbers.

Electric Heaters - Models shown under Electrical Data include sequencers and temperature limit switches and fusible links for safe, efficient operation. Circuit breakers are provided where shown.

Suspension Kit - Suspension Kit Model 1BH0601 is designed specifically for upflow application of the units contained in this technical guide. For suspension of these units in horizontal applications, it is recommended to use angle support brackets with threaded rods at locations shown in air handler installation instructions.

Filter Rack - One of the following external filter rack accessories: 1FR07* or 1FR08* must be used when unit is installed for application outlined.

Combustible Floor Base - If an electric heat accessory which is rated for greater than zero clearance to combustible surfaces is installed in these air handlers in the downflow operating positions on a combustible floor, one of the following combustible floor base accessories is required: 1FB1817, 1FB1821, or 1FB1824.

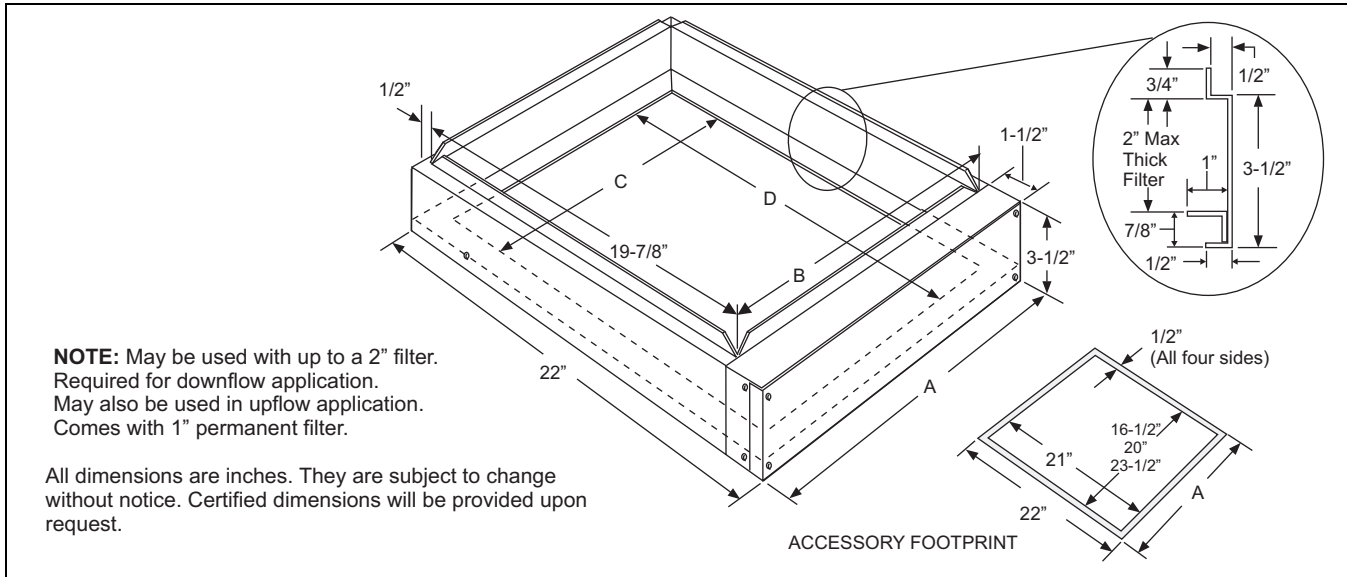

FILTER RACK ACCESSORY

Filter Rack Model		Used With	Rack Dimensions Inches				Filter Dimensions Inches		
Multi-Position	Horizontal Only		A	B	C	D	Width	Length	Thickness
1FR0817	1FR0717	MV12B	17-1/2	16-3/8	15-1/2	21	16	20	1
1FR0821	1FR0721	MV16C	21	19-7/8	19	21	20	20	1
1FR0824	1FR0724	MV12D, MV20D	24-1/2	23-3/8	22-1/2	21	24	20	1

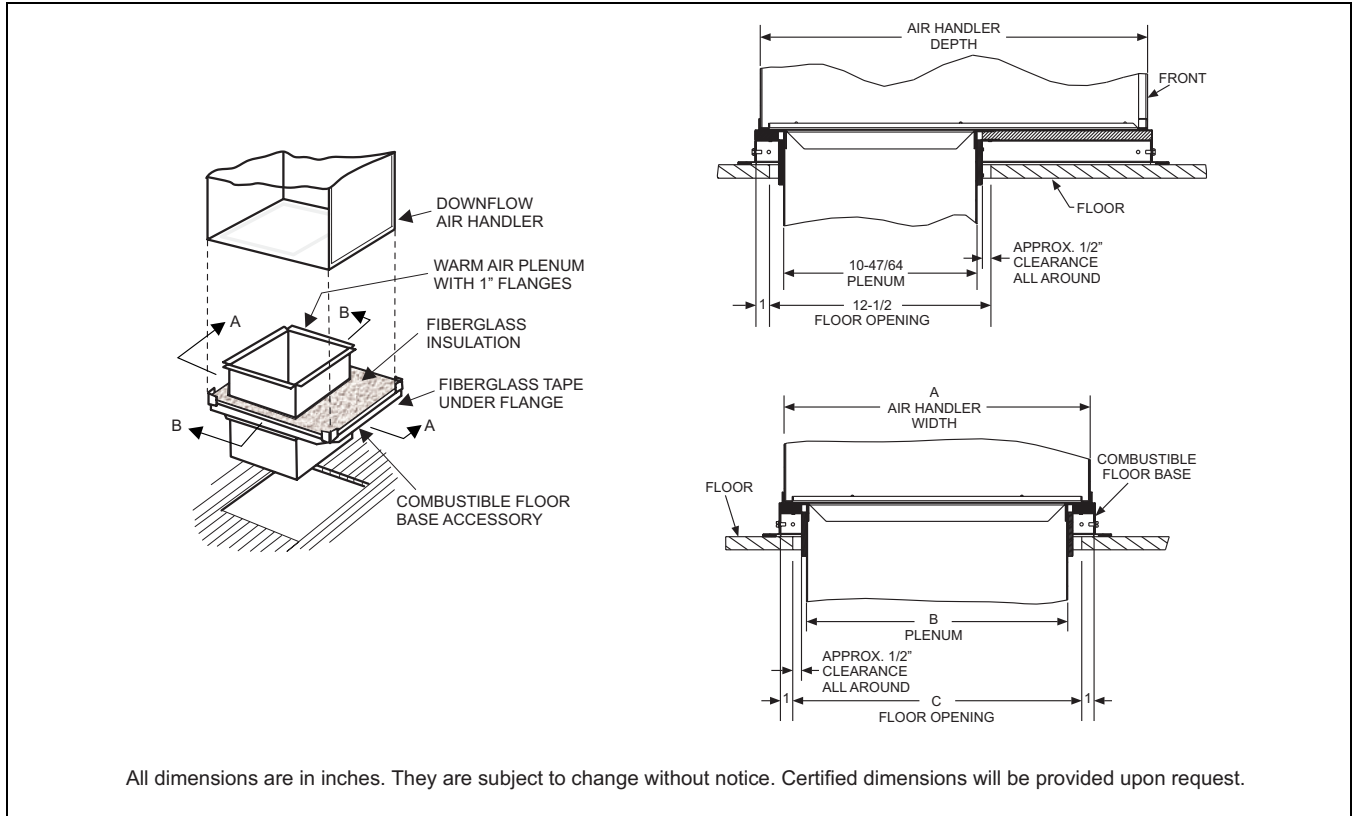

COMBUSTIBLE FLOOR BASE ACCESSORY

Floor Base Model	Used with	Dimensions			
		A	B	C	D
1FB1817	MV12B	19.9	18.0	14.9	16.9
1FB1821	MV16C	23.4	21.5	18.4	20.4
1FB1824	MV12D, MV20D	26.9	25.0	21.9	23.9

COOLING AIRFLOW DATA - MV MODELS

HIGH / LOW SPEED COOLING AND HEAT PUMP CFM									
12B Air Handler				12D Air Handler				JUMPER SETTINGS	
CFM		m ³ /min		CFM		m ³ /min			
High	Low	High	Low	High	Low	High	Low	COOL Tap	ADJ Tap*
1307	882	37.0	25.0	1366	869	38.7	24.6	A	B
1080	756	30.6	21.4	1097	717	31.1	20.3	B	B
1270	862	36.0	24.4	1312	856	37.2	24.2	A	A
943	689	26.7	19.5	957	646	27.1	18.3	B	A
1146	786	32.5	22.3	1167	761	33.0	21.5	A	C
1050	726	29.7	20.6	1051	703	29.8	19.9	C	B
870	632	24.6	17.9	863	580	24.4	16.4	B	C
771	594	21.8	16.8	739	520	20.9	14.7	D	B
931	668	26.4	18.9	927	629	26.2	17.8	C	A
693	565	19.6	16.0	658	495	18.6	14.0	D	A
851	624	24.1	17.7	830	567	23.5	16.1	C	C
655	567	18.5	16.1	594	488	16.8	13.8	D	C
16C Air Handler				20D Air Handler				JUMPER SETTINGS	
CFM		m ³ /min		CFM		m ³ /min			
High	Low	High	Low	High	Low	High	Low	COOL Tap	ADJ Tap*
1920	1321	54.4	37.4	2209	1394	62.6	39.5	A	B
1699	1189	48.1	33.7	2022	1394	57.3	39.5	B	B
1884	1296	53.3	36.7	2178	1381	61.7	39.1	A	A
1558	1094	44.1	31.0	1798	1378	50.9	39.0	B	A
1714	1193	48.5	33.8	1965	1226	55.6	34.7	A	C
1451	1037	41.1	29.4	1843	1143	52.2	32.4	C	B
1403	1009	39.7	28.6	1596	1226	45.2	34.7	B	C
1288	947	36.5	26.8	1700	1066	48.1	30.2	D	B
1336	978	37.8	27.7	1608	1023	45.5	29.0	C	A
1214	888	34.4	25.1	1493	967	42.3	27.4	D	A
1239	915	35.1	25.9	1430	911	40.5	25.8	C	C
1098	839	31.1	23.8	1334	877	37.8	24.8	D	C

All CFM's are shown at 0.5" w.c. external static pressure. These units have variable speed motors that automatically adjust to provide constant CFM from 0.0" to 0.6" w.c. static pressure. From 0.6" to 1.0" static pressure, CFM is reduced by 2% per 0.1" increase in static. Operation on duct systems with greater than 1.0" w.c. external static pressure is not recommended.

NOTE: At some settings, LOW COOL and/or LOW HEAT airflow may be lower than what is required to operate an airflow switch on certain models of electronic air cleaners. Consult the instructions for the electronic air cleaner for further details.

* The ADJ "D" tap should not be used.

HEATING AIRFLOW DATA - MV MODELS

HIGH / LOW SPEED COOLING AND HEAT PUMP CFM									
12B Air Handler				12D Air Handler				JUMPER SETTINGS	
CFM		m ³ /min		CFM		m ³ /min			
High	Low	High	Low	High	Low	High	Low	COOL Tap	ADJ Tap*
1270	791	36.0	22.4	1312	762	37.2	21.6	A	A
943	714	26.7	20.2	957	668	27.1	18.9	B	A
931	643	26.4	18.2	927	591	26.2	16.7	C	A
693	567	19.6	16.1	658	488	18.6	13.8	D	A
16C Air Handler				20D Air Handler				JUMPER SETTINGS	
CFM		m ³ /min		CFM		m ³ /min			
High	Low	High	Low	High	Low	High	Low	COOL Tap	ADJ Tap*
1884	1217	53.3	34.5	2178	1217	61.7	34.5	A	A
1558	1065	44.1	30.2	1798	1036	50.9	29.3	B	A
1336	823	37.8	23.3	1608	748	45.5	21.2	C	A
1214	727	34.4	20.6	1493	551	42.3	15.6	D	A

All CFM's are shown at 0.5" w.c. external static pressure. These units have variable speed motors that automatically adjust to provide constant CFM from 0.0" to 0.6" w.c. static pressure. From 0.6" to 1.0" static pressure, CFM is reduced by 2% per 0.1" increase in static. Operation on duct systems with greater than 1.0" w.c. external static pressure is not recommended.

NOTE: At some settings, LOW COOL and/or LOW HEAT airflow may be lower than what is required to operate an airflow switch on certain models of electronic air cleaners. Consult the instructions for the electronic air cleaner for further details.

* The ADJ "D" tap should not be used.

APPLICATION FACTORS - RATED CFM VS. ACTUAL CFM

	% OF RATED AIR FLOW	80%	90%	RATED CFM	110%	120%
	CAPACITY FACTOR	0.96	0.98	1.00	1.02	1.03

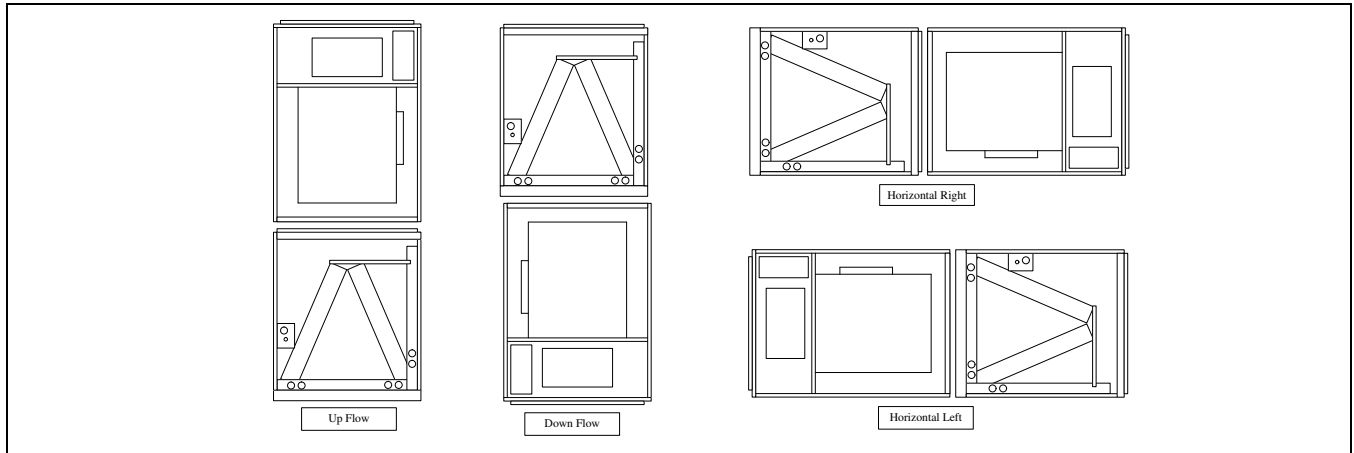

Typical Applications with MC Multi-Position Coils

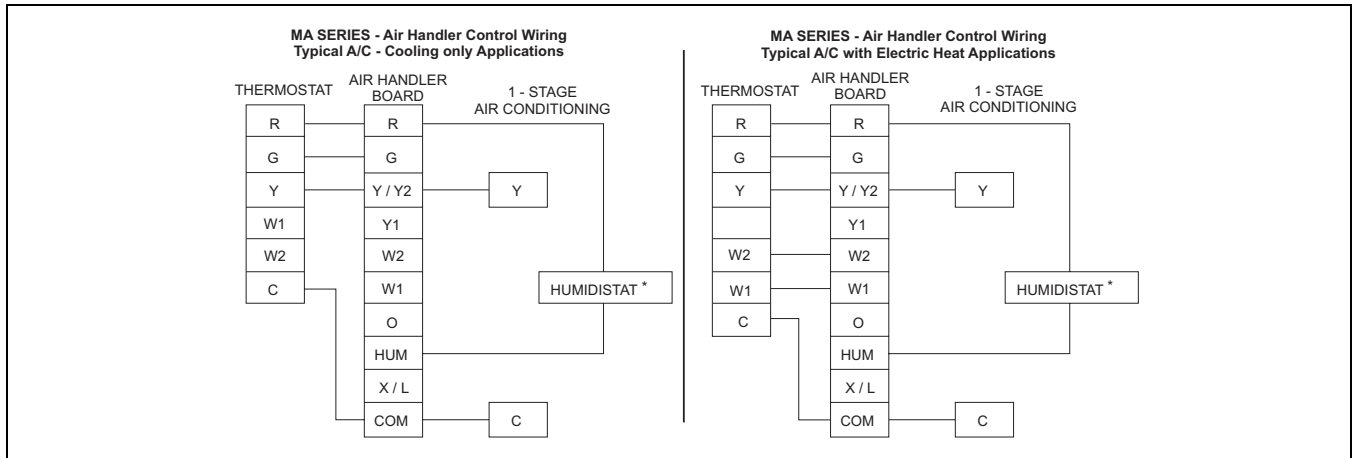

COOLING MODELS WITH ELECTRIC HEAT

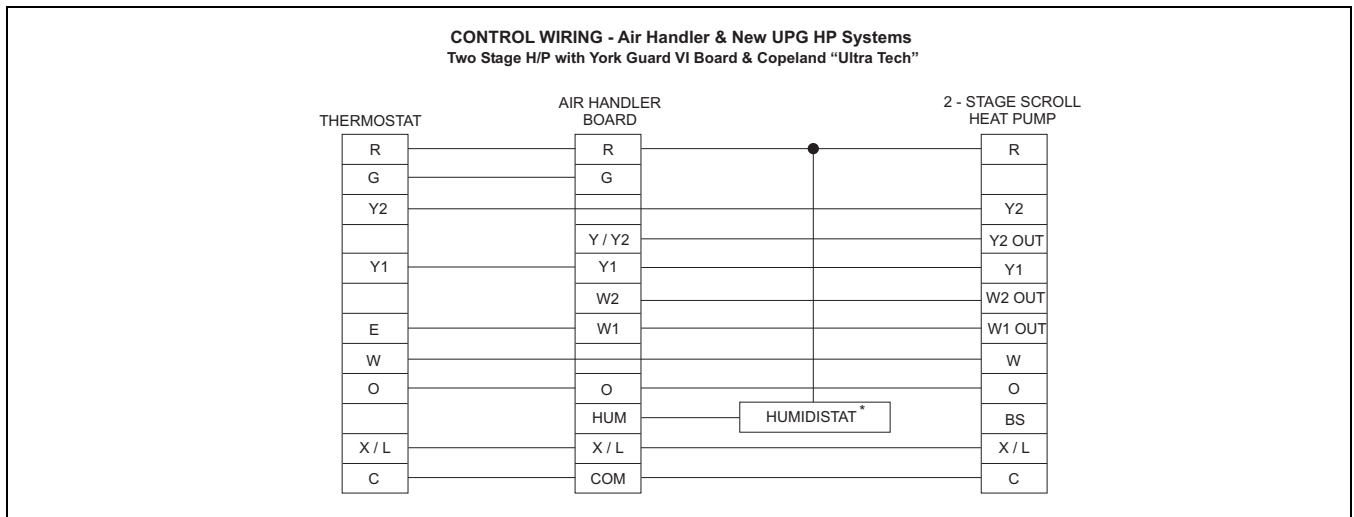

CONTROL WIRING - MV SERIES

* Optional dehumidification humidistat switch contacts open on humidity rise.

NOTES

Subject to change without notice. Printed in U.S.A.
Copyright © by York International Corp. 2006. All rights reserved.

255428-BTG-H-1206
Supersedes: 255428-BTG-G-1106

**Unitary
Products
Group**

**5005
York
Drive**

**Norman
OK
73069**