



TECHNICAL GUIDE

SINGLE PIECE VARIABLE SPEED AIR HANDLERS

FOR USE WITH SPLIT-SYSTEM
COOLING & HEAT PUMPS

MODELS: AVC24 THRU 60 AND SVC48 THRU 60



Due to continuous product improvement,
specifications are subject to change without notice.

Visit us on the web at www.york.com

Additional rating information can be found at
www.ahridirectory.org.

DESCRIPTION

The Echelon Air Handler line offers the ultimate in comfort, sound and application flexibility. The Echelon models utilize a whisper quiet variable speed motor that provides humidity control and the lowest operating cost in the industry. The AVC air handler is shipped ready to be installed in all positions, upflow, downflow, horizontal left or right, with minor adjustments. The SVC 48 & 60 models are upflow only models designed into a shorter cabinet, for those special applications where reduced height is required. No special kits are required to install this deluxe product in any position.

All JCI Unitary Products air handlers and coils use a TXV to provide our customers with the optimum performance and refrigerant control required for 13 + Seer systems. Air handlers can be ordered with either a R-22 or R-410A TXV factory installed. Air handlers are also available with "Flex-coils" without a factory installed metering device, where for added flexibility, a R-22 or R-410A TXV can be field installed to meet your refrigerant choice.

FEATURE

Thermal Expansion Valve - Provides the ultimate refrigerant control required for today's high efficient product. The UPG bolt-on TXV provides easy installation to convert the air handler to the required refrigerant, which is a true bolt-on design that does not require brazing to replace or install.

MicroBlue™ Coated Fins - All air handler coils are treated with the MicroBlue™ hydrophilic coating to enhance the removal of condensate during the refrigeration cycle and reduce the possibility of water blow-off. The MicroBlue™ coating also reduces the growth of germ causing microbes for a healthier home environment.

Insulated Cabinet - All air handler cabinets are thermally insulated with 1" foil faced insulation (R-4.2) to prevent sweating. For applications in extreme humidity conditions an optional, field installed, external insulating wrap kit is also available.

Factory - Sealed to achieve 2% or less leakage rate with or without field installed filter at 1.0" water gauge external static pressure.

Durable Finish Inside and Out - Air handler casings are made of pre-painted galvanized steel which provides a better paint to steel bond that resists corrosion and rust creep. All internal coil sheet metal parts are made of G90 galvanized.

New 4 HK Heat Kit - Installation friendly, easy service, more robust, unique to new design.

ECM Variable Speed Motor - Designed for efficient, quiet operation with added indoor comfort control. With the use of a humidistat, the motor will monitor the humidity in the home and automatically keep the desired humidity level in both winter and summer seasons. The ECM motor utilizes only 24% of the energy used by standard blower motors to reduce your overall heating and cooling costs.

EcoTrak Comfort Settings - Installers can set an operating cycle for the ECM motor that works best in a particular climate. Homeowners benefit from an operating cycle that maximizes their indoor comfort level regardless of whether they live in a dry, temperate, or humid climate.

DIMENSIONS

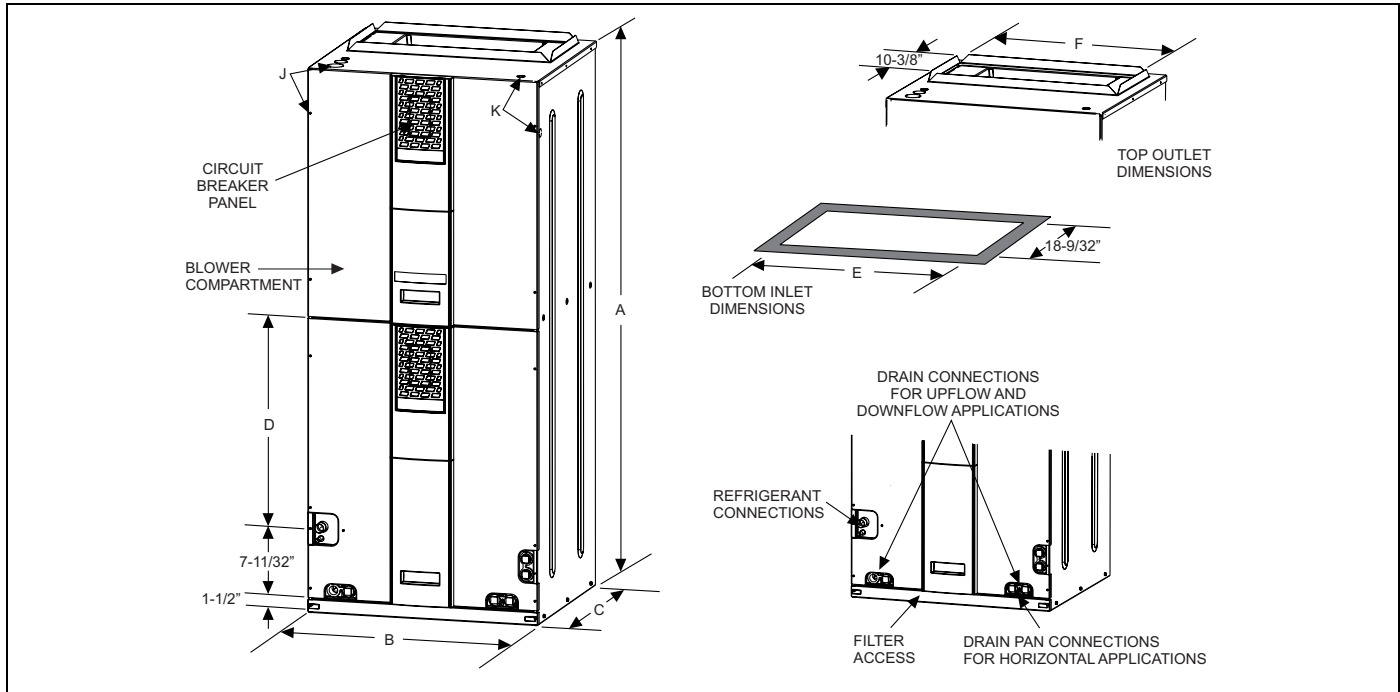

DIMENSIONS

Models	Dimensions (Inches)						Wiring Knockouts ¹		Refrigerant Connections Line Size	
	A	B	C	D	E	F	J	K	Liquid	Vapor
	Height	Width	Depth				Power	Control		
AVC24B**H21	46	17.5	21.5 (w/o cladding)	12-3/8	13-29/32	14-19/32	7/8" (1/2") 1 3/8" (1") 1 23/32" (1 1/4")	7/8" (1/2")	3/8"	3/4"
AVC36C**H21	52	21		17-1/8	17-13/32	18-3/32				7/8"
AVC48D**H21	57	24.5	22-1/8	20-29/32	21-19/32	7/8"				
SVC48D**N21	52	24.5	17-1/8	20-29/32	21-19/32	7/8"				
AVC60D**H21	57	24.5	22-1/8	20-29/32	21-19/32	7/8"				
SVC60D**N21	52	24.5	17-1/8	20-29/32	21-19/32	7/8"				

1. Actual size (Conduit size).

** Thermal expansion device indicators - "2_" indicates R-22 TXV is factory installed, "3X" indicates unit is a "Flex Coil" models with a field installed R-22 or R-410A TXV, and "4_" indicates R-410A TXV is factory installed. Letter indicates TXV size as required, see outdoor unit technical information for proper matches and requirements.

COIL TECHNICAL DATA

Models	Application	Refrig. Conn. Types	Face Area (Sq. Ft.)	Rows Deep	Fin Per In.	Coil Size	Tube Geometry	Tube Dia.	Fin Type	TXV
AVC24B3XH21	Cooling / Heat Pump	Sweat	3.89	2	14	(2) 16 x 17.5	1 x 0.866	3/8	Enhanced	None
AVC24B2AH21										2A
AVC24B4EH21										4E
AVC24B4FH21										4F
AVC24B4KH21										4K
AVC36C3XH21	Cooling / Heat Pump	Sweat	4.86	3	12	(2) 20 x 17.5	1 x 0.866	3/8	Enhanced	None
AVC36C2AH21										2A
AVC36C4EH21										4E
AVC36C4FH21										4F
AVC36C4GH21										4G
AVC36C4HH21										4H
AVC36C4KH21										4K
AVC36C4MH21	4M									
AVC48D3XH21	Cooling / Heat Pump	Sweat	5.83	3	11	(2) 24 x 17.5	1 x 0.866	3/8	Enhanced	None
AVC48D2CH21										2C
AVC48D4FH21										4F
AVC48D4HH21										4H
AVC48D4JH21										4J
AVC48D4KH21										4K
SVC48D3XN21										None
SVC48D2CN21	2C									
AVC60D3XH21	Cooling / Heat Pump	Sweat	5.83	3	11	(2) 24 x 17.5	1 x 0.866	3/8	Enhanced	None
AVC60D2CH2										2C
AVC60D4HH21										4H
AVC60D4JH21										4J
AVC60D4KH21										4K
SVC60D3XN21										None
SVC60D2CN21										2C

Note: H models are available with a factory installed horizontal drain pan.

COOLING CAPACITY

Models	Rated CFM	Entering Air °F (Dry / Wet Bulb)	MBH@ Evaporator Temperature and Corresponding Pressure °F / PSIG			
			35 / 61.5	40 / 68.5	45 / 76.0	50 / 84.0
FULL-CASED "A" TYPE MULTI-POSITION						
AVC24B**H21	800	85/72	35.0	31.8	28.4	24.7
		80/67	32.2	29.1	25.7	22.3
		75/62	26.4	23.4	21.0	17.1
		70/57	21.4	18.6	20.2	12.1
AVC36C**H21	1200	85/72	51.3	46.7	41.7	36.8
		80/67	41.1	36.3	31.8	27.1
		75/62	32.1	27.0	29.4	21.9
		70/57	27.6	25.4	23.5	18.3
AVC48D**H21 SVC48D**N21	1600	85/72	100.5	86.4	72.0	56.8
		80/67	80.4	67.5	55.0	42.1
		75/62	62.7	49.9	40.7	34.0
		70/57	53.9	47.2	36.81	28.71
AVC60D**H21 SVC60D**N21	1850	85/72	119.9	101.0	82.0	62.2
		80/67	96.0	79.2	62.6	45.8
		75/62	74.8	58.6	46.2	37.0
		70/57	64.3	55.4	43.2	33.7

COOLING AIR FLOW DATA

HIGH / LOW SPEED COOLING AND HEAT PUMP CFM					
AVC24B**H21		AVC36C**H21		JUMPER SETTINGS	
CFM		CFM			
High	Low	High	Low	COOL Tap	ADJ Tap*
1010	662	1230	873	A	B
816	534	1007	810	B	B
933	620	1202	811	A	A
706	460	903	640	B	A
926	615	1076	736	A	C
594	393	965	688	C	B
636	431	814	599	B	C
505	380	714	552	D	B
524	373	868	626	C	A
448	380	646	520	D	A
519	378	799	588	C	C
447	380	604	523	D	C
AVC48D**H21, SVC48D**N21		AVC60D**H21, SVC60D**N21		JUMPER SETTINGS	
CFM		CFM			
High	Low	High	Low	COOL Tap	ADJ Tap*
2020	1333	2166	1354	A	B
1759	1194	1970	1242	B	B
1989	1307	2134	1343	A	A
1607	1079	1769	1082	B	A
1790	1209	1895	1184	A	C
1502	1038	1826	1167	C	B
1439	1000	1526	978	B	C
1306	951	1654	1037	D	B
1368	973	1596	1025	C	A
1218	885	1434	928	D	A
1246	902	1397	934	C	C
1090	834	1283	861	D	C

All CFM's are shown at 0.5" w.c. external static pressure. These units have variable speed motors that automatically adjust to provide constant CFM from 0.0" to 0.6" w.c. static pressure. From 0.6" to 1.0" static pressure, CFM is reduced by 2% per 0.1" increase in static. Operation on duct systems with greater than 1.0" w.c. external static pressure is not recommended.

NOTE: At some settings, LOW COOL and/or LOW HEAT airflow may be lower than what is required to operate an airflow switch on certain models of electronic air cleaners. Consult the instructions for the electronic air cleaner for further details.

* The ADJ "D" tap should not be used.

HEATING AIR FLOW DATA

HIGH / LOW HEAT CFM					
24B Air Handler		36C Air Handler		JUMPER SETTINGS	
CFM	CFM	CFM	CFM		
High	Low	High	Low	HEAT Tap	ADJ Tap
933	681	1202	724	A	A
706	607	903	657	B	A
524	523	868	593	C	A
448	389	646	520	D	A
48D Air Handler		60D Air Handler		JUMPER SETTINGS	
CFM	CFM	CFM	CFM		
High	Low	High	Low	HEAT Tap	ADJ Tap
1942	1318	2134	1212	A	A
1607	1142	1769	1021	B	A
1358	927	1596	713	C	A
1305	673	1434	522	D	A

All CFM's are shown at 0.5" w.c. external static pressure. These units have variable speed motors that automatically adjust to provide constant CFM from 0.0" to 0.6" w.c. static pressure. From 0.6" to 1.0" static pressure, CFM is reduced by 2% per 0.1" increase in static. Operation on duct systems with greater than 1.0" w.c. external static pressure is not recommended.
 NOTE: At some settings, LOW COOL and/or LOW HEAT airflow may be lower than what is required to operate an airflow switch on certain models of electronic air cleaners. Consult the instructions for the electronic air cleaner for further details.
 * The ADJ "D" tap should not be used.

APPLICATION FACTORS - RATED CFM VS. ACTUAL CFM

% Of Rated Airflow	80%	90%	Rated CFM	110%	120%
Capacity Factor	0.96	0.98	1.00	1.02	1.03

PHYSICAL & ELECTRICAL DATA - COOLING ONLY (60 Hz)

Models		AVC24B**H21	AVC36C**H21	AVC48D**H21 SVC48D**N21	AVC60D**H21 SVC60D**N21
Blower - Diameter x Width		10 x 7	10 x 7	10 x 10	10 x 10
Motor	HP	1/3	1/2	3/4	1
	Nominal RPM	1200	1200	1200	1200
Voltage		230			
Amps	Full Load (230)	2.8	4.3	5.5	7.0
	Type	DISPOSABLE OR PERMANENT			
Filter ¹	Size	16 x 20 x1	20 x 20 x1	22 x 20 x1	22 x 20 x1
	Permanent Type Kit	1PF0601BK	1PF0602BK	1PF0603BK	1PF0603BK
Shipping / Operating Weight (lbs.)		140/134	170/164	AV - 196/185 SV - 194/181	AV - 199/188 SV - 195/184

1. Field supplied.

ELECTRICAL DATA - COOLING ONLY (60 Hz)

Models	Total Motor Amps		Minimum Circuit Ampacity		Max. O.C.P. Amps/Type ¹	Minimum Wire Size A.W.G.
	60 Hertz		60 Hertz			
	208V	230V	208V	230V		
AVC24B**H21	3.2	2.8	4.0	3.5	15	14
AVC36C**H21	4.7	4.3	5.9	5.4	15	14
AVC48D**H21	6.1	5.0	7.6	6.9	15	14
SVC48D**N21	6.1	5.0	7.6	6.9	15	14
AVC60D**H21	7.8	7.0	9.7	8.8	15	14
SVC60D**N21	7.8	7.0	9.7	8.8	15	14

1. OCP = Over Current Protection device, must be HACR type Circuit Breaker or Time Delay fuse.

ELECTRICAL DATA - 208/230-1-60

Models	Heat Kits*	Max. Static	Min. Speed Tap	Total Heat ¹				kW Staging					
				KW		MBH		W1 Only		W2 Only		W1 & W2	
				208v	240v	208v	240v	208v	240v	208v	240v	208v	240v
AVC24B**H21	4HK*6500206	0.5	Heat-D	1.9	2.5	6.4	8.5	1.9	2.5	1.9	2.5	1.9	2.5
	4HK*6500506	0.5	Heat-D	3.6	4.8	12.3	16.4	3.6	4.8	3.6	4.8	3.6	4.8
	4HK*6500806	0.5	Heat-D	5.6	7.5	19.2	25.6	2.8	3.75	5.6	7.5	5.6	7.5
	4HK*6501006	0.5	Heat-D	7.2	9.6	24.6	32.8	3.6	4.8	7.2	9.6	7.2	9.6
	4HK165N1506	0.5	Heat-D	10.8	14.4	36.9	49.1	3.6	4.8	7.2	9.6	10.8	14.4
AVC36C**H21	4HK*6500506	0.5	Heat-D	3.6	4.8	12.3	16.4	3.6	4.8	3.6	4.8	3.6	4.8
	4HK*6500806	0.5	Heat-D	5.6	7.5	19.2	25.6	2.8	3.75	5.6	7.5	5.6	7.5
	4HK*6501006	0.5	Heat-D	7.2	9.6	24.6	32.8	3.6	4.8	7.2	9.6	7.2	9.6
	4HK16501506	0.5	Heat-D	10.8	14.4	36.9	49.1	3.6	4.8	7.2	9.6	10.8	14.4
	4HK16501806	0.5	Heat-D	13.2	17.6	45.1	60.1	3.3	4.4	6.6	8.8	13.2	17.6
AVC48D**H21 SVC48D**N21	4HK*6500506	0.5	Heat-D	3.6	4.8	12.3	16.4	3.6	4.8	3.6	4.8	3.6	4.8
	4HK*6500806	0.5	Heat-D	5.6	7.5	19.2	25.6	2.8	3.75	5.6	7.5	5.6	7.5
	4HK*6501006	0.5	Heat-D	7.2	9.6	24.6	32.8	3.6	4.8	7.2	9.6	7.2	9.6
	4HK16501506	0.5	Heat-D	10.8	14.4	36.9	49.1	3.6	4.8	7.2	9.6	10.8	14.4
	4HK16501806	0.5	Heat-D	13.2	17.6	45.1	60.1	3.3	4.4	6.6	8.8	13.2	17.6
	4HK16502006	0.5	Heat-D	14.4	19.2	49.2	65.5	3.6	4.8	7.2	9.6	14.4	19.2
	4HK*6502506	0.5	Heat-D	18.0	24.0	61.5	81.9	3.6	4.8	10.8	14.4	18.0	24
AVC60D**H21 SVC60D**N21	4HK*6500506	0.5	Heat-D	3.6	4.8	12.3	16.4	3.6	4.8	3.6	4.8	3.6	4.8
	4HK*6500806	0.5	Heat-D	5.6	7.5	19.2	25.6	2.8	3.75	5.6	7.5	5.6	7.5
	4HK*6501006	0.5	Heat-D	7.2	9.6	24.6	32.8	3.6	4.8	7.2	9.6	7.2	9.6
	4HK16501506	0.5	Heat-D	10.8	14.4	36.9	49.1	3.6	4.8	7.2	9.6	10.8	14.4
	4HK16501806	0.5	Heat-D	13.2	17.6	45.1	60.1	3.3	4.4	6.6	8.8	13.2	17.6
	4HK16502006	0.5	Heat-D	14.4	19.2	49.2	65.5	3.6	4.8	7.2	9.6	14.4	19.2
	4HK16502506	0.5	Heat-D	18.0	24.0	61.5	81.9	3.6	4.8	10.8	14.4	18.0	24

1. See conversion Table 10.

* May be 0 (no breaker) or 1 (with breaker).

KW & MBH CONVERSIONS - FOR TOTAL POWER INPUT REQUIREMENT

FOR	208V	OPERATION MULTIPLY	240V	TABULATED KW & MBH BY	.751
	230V		240V		.918
	220V		240V		.840

COMFORT SETTINGS SELECTION

Delay Tap	Comfort Setting
A	Normal
B	Humid
C	Dry
D	Temperate

ELECTRICAL DATA (FOR SINGLE SOURCE POWER SUPPLY) - COPPER WIRE 208/230-1-60

Models	Heat Kit - Single Phase*	Heater Amps 240V	Field Wiring					
			Min. Circuit Ampacity		Max. O.C.P. Amps/Type ¹		75°C Wire Size - AWG	
			208V	240V	208V	240V	208V	240V
AVC24B**H21	4HK*6500206	10.4	15.28	16.53	20	20	12	12
	4HK*6500506	20.0	25.67	28.50	30	30	10	10
	4HK*6500806	31.3	37.85	42.63	45	45	8	8
	4HK*6501006	40.0	47.33	53.50	50	60	8	6
	4HK165N1506	60.0	69.00	78.50	70	90	4	3
AVC36C**H21	4HK*6500506	20.0	27.54	30.38	30	35	10	10
	4HK*6500806	31.3	39.73	44.50	45	45	8	8
	4HK*6501006	40.0	49.21	55.38	50	60	8	6
	4HK16501506	60.0	70.88	80.38	70	90	4	3
	4HK16501806	73.3	85.32	97.00	90	100	4	3
AVC48D**H21 SVC48D**N21	4HK*6500506	20.0	29.29	31.88	35	35	8	8
	4HK*6500806	31.3	41.48	46.00	45	50	8	8
	4HK*6501006	40.0	50.96	56.88	60	60	6	6
	4HK16501506	60.0	72.63	81.88	90	90	3	3
	4HK16501806	73.3	87.07	98.50	90	100	3	2
	4HK16502006	80.0	94.29	106.88	100	125	3	1
	4HK16502506	100.0	115.96	131.88	125	150	1	1/0
AVC60D**H21 SVC60D**N21	4HK*6500506	20.0	31.42	33.75	35	35	8	8
	4HK*6500806	31.3	43.60	47.88	45	50	8	8
	4HK*6501006	40.0	53.08	58.75	60	60	6	6
	4HK16501506	60.0	74.75	83.75	90	90	3	3
	4HK16501806	73.3	89.19	100.38	90	110	3	2
	4HK16502006	80.0	96.42	108.75	100	125	3	1
	4HK16502506	100.0	118.08	133.75	125	150	1	1/0

1. O.C.P. = Over Current Protection device, must be HACR type Circuit Breaker or Time Delay fuse.

* May be 0 (no breaker) or 1 (with breaker).

ELECTRICAL DATA (FOR MULTI SOURCE POWER SUPPLY) - COPPER WIRE 208/230-1-60

Models	Heater Model	Min. Circuit Ampacity			Max. O.C.P. Amps/Type ¹			75°C Wire Size - AWG		
		Circuit			Circuit			Circuit		
		1st	2nd	3rd	1st	2nd	3rd	1st	2nd	3rd
		208/240	208/240	208/240	208/240	208/240	208/240	208/240	208/240	208/240
AVC24B**H21	4HK165N1506	47.5 / 53.5	21.7 / 25.0	—	50 / 60	25 / 25	—	8 / 6	10 / 10	—
AVC36C**H21	4HK16501506	48.5 / 55.4	21.7 / 25.0	—	50 / 60	25 / 25	—	8 / 6	10 / 10	—
	4HK16501806	44.9 / 51.2	39.8 / 45.8	—	45 / 60	40 / 50	—	8 / 8	8 / 8	—
AVC48D**H21 SVC48D**N21	4HK16501506	51.0 / 56.9	21.7 / 25.0	—	60 / 60	25 / 25	—	6 / 6	10 / 10	—
	4HK16501806	47.4 / 52.7	39.8 / 45.8	—	50 / 60	40 / 60	—	6 / 6	8 / 6	—
	4HK16502006	51.0 / 56.9	43.4 / 50.0	—	60 / 60	45 / 50	—	6 / 6	8 / 8	—
	4HK16502506	51.0 / 56.9	43.4 / 50.0	21.7 / 25.0	60 / 60	45 / 50	25 / 25	6 / 6	8 / 8	10 / 10
AVC60D**H21 SVC60D**N21	4HK16501506	53.1 / 58.8	21.7 / 25.0	—	60 / 60	25 / 25	—	6 / 6	10 / 10	—
	4HK16501806	49.5 / 54.6	39.8 / 45.8	—	50 / 60	40 / 60	—	6 / 6	8 / 6	—
	4HK16502006	53.1 / 58.8	43.4 / 50.0	—	60 / 60	45 / 50	—	6 / 6	8 / 8	—
	4HK16502506	53.1 / 58.8	43.4 / 50.0	21.7 / 25.0	60 / 60	45 / 50	25 / 25	6 / 6	8 / 8	10 / 10

1. O.C.P. = Over Current Protection device, must be HACR type Circuit Breaker or Time Delay fuse.

ELECTRICAL DATA - 208/230-3-60

Models	Heat Kit - Three Phase	Max. Static	Min. Speed Tap	Total Heat ¹				KW Staging					
				KW		MBH		W1 Only		W2 Only		W1 + W2	
				208V	240V	208V	240V	208V	240V	208V	240V	208V	240V
AVC24B**H21	4HK06501025	0.5	Heat-D	7.2	9.6	24.6	32.8	7.2	9.6	7.2	9.6	7.2	9.6
AVC36C**H21	4HK06501025	0.5	Heat-D	7.2	9.6	24.6	32.8	7.2	9.6	7.2	9.6	7.2	9.6
	4HK06501525	0.5	Heat-D	10.8	14.4	36.9	49.1	10.8	14.4	10.8	14.4	10.8	14.4
AVC48D**H21 SVC48D**N21	4HK06501025	0.5	Heat-D	7.2	9.6	24.6	32.8	7.2	9.6	7.2	9.6	7.2	9.6
	4HK06501525	0.5	Heat-D	10.8	14.4	36.9	49.1	10.8	14.4	10.8	14.4	10.8	14.4
	4HK06501825	0.5	Heat-D	12.9	17.2	44.7	58.7	12.9	17.2	12.9	17.2	12.9	17.2
AVC60D**H21 SVC60D**N21	4HK06501025	0.5	Heat-D	7.2	9.6	24.6	32.8	7.2	9.6	7.2	9.6	7.2	9.6
	4HK06501525	0.5	Heat-D	10.8	14.4	36.9	49.1	10.8	14.4	10.8	14.4	10.8	14.4
	4HK16502525	0.5	Heat-D	18.0	24.0	61.4	81.4	9.0	12.0	18.0	24.0	18.0	24.0

1. See conversion table on Page 5.

ELECTRICAL DATA (FOR SINGLE SOURCE POWER SUPPLY) - COPPER WIRE 208/230-3-60

Models	Heat Kit - Three Phase	Heater Amps 240V	Field Wiring					
			Min. Circuit Ampacity		Max. O.C.P. ¹ Amps/Type		75°C Wire Size - AWG	
			208V	240V	208V	240V	208V	240V
AVC24B**H21	4HK06501025	23.1	28.5	32.4	30	35	10	8
AVC36C**H21	4HK06501025	23.1	30.4	34.3	30	35	10	8
	4HK06501525	34.7	42.9	48.8	45	50	8	8
AVC48D**H21 SVC48D**N21	4HK06501025	23.1	31.3	35.1	35	35	8	8
	4HK06501525	34.7	43.8	49.6	45	50	8	8
	4HK06501825	41.4	51.0	58.0	60	60	6	6
AVC60D**H21 SVC60D**N21	4HK06501025	23.1	33.8	37.6	35	40	8	8
	4HK06501525	34.7	46.3	52.1	50	60	8	6

1. O.C.P. = Over Current Protection device, must be HACR type Circuit Breaker or Time Delay fuse.

ELECTRICAL DATA (FOR MULTI SOURCE POWER SUPPLY) - COPPER WIRE 208/230-3-60

Models	Heater Model	Minimum Circuit Ampacity			Max. O.C.P. ¹ Amps/Type			75°C Wire Size - AWG		
		Circuit								
		1st	2nd	3rd	1st	2nd	3rd	1st	2nd	3rd
AVC60D**H21 SVC60D**N21	4HK16502525	41.0 / 44.9	31.3 / 36.1	- / -	45 / 45	35 / 40	- / -	8 / 8	8 / 8	- / -

1. O.C.P. = Over Current Protection device, must be HACR type Circuit Breaker or Time Delay fuse.

ACCESSORIES

Refer to Price Manual for specific model numbers where not shown.

TXV Kits - TXV kits are available for “Flex-coil” applications and converting R-22 to R-410A or as a service replacement. All kits are bolt-on and require no brazing to install.

Electric Heaters - 4HK models shown under electrical data include sequential operation and temperature dual limit switches for safe, efficient operation. Circuit breakers are provided where shown.

External Insulating Wrap Kit - Provides a vinyl covered thermal insulation wrap, providing additional thermal insulation protection to prevent sweating in applications where extreme high humidity is present. Air Handler cover (or wrap) has Velcro edges for easy installation and access.

- S1-1JV0117
- S1-1JV0121
- S1-1JV0124
- S1-1JV0224 (SV* models only)

Humidstat - S1-2HU16700124

Control when used with ECM variable speed models will monitor humidity level in both winter and summer seasons. Adjusts blower speed and airflow provided to maintain desired humidity levels.

LIMITATIONS

These units must be wired and installed in accordance with all national and local safety codes.

Voltage limits are as follows:

Air Handler Voltage	Voltage code	¹ Normal Operating Voltage Range
208/230-1-60	06	187-253

1. Rated in accordance with ARI Standard 110, utilization range “A”.

Airflow must be within the minimum and maximum limits approved for electric heat, evaporator coils and outdoor units.

Entering Air Temperature Limits			
Wet Bulb Temp. °F		Dry Bulb Temp. °F	
Min.	Max.	Min.	Max.
57	72	65	95

COOLING MODELS WITH ELECTRIC HEAT WIRING

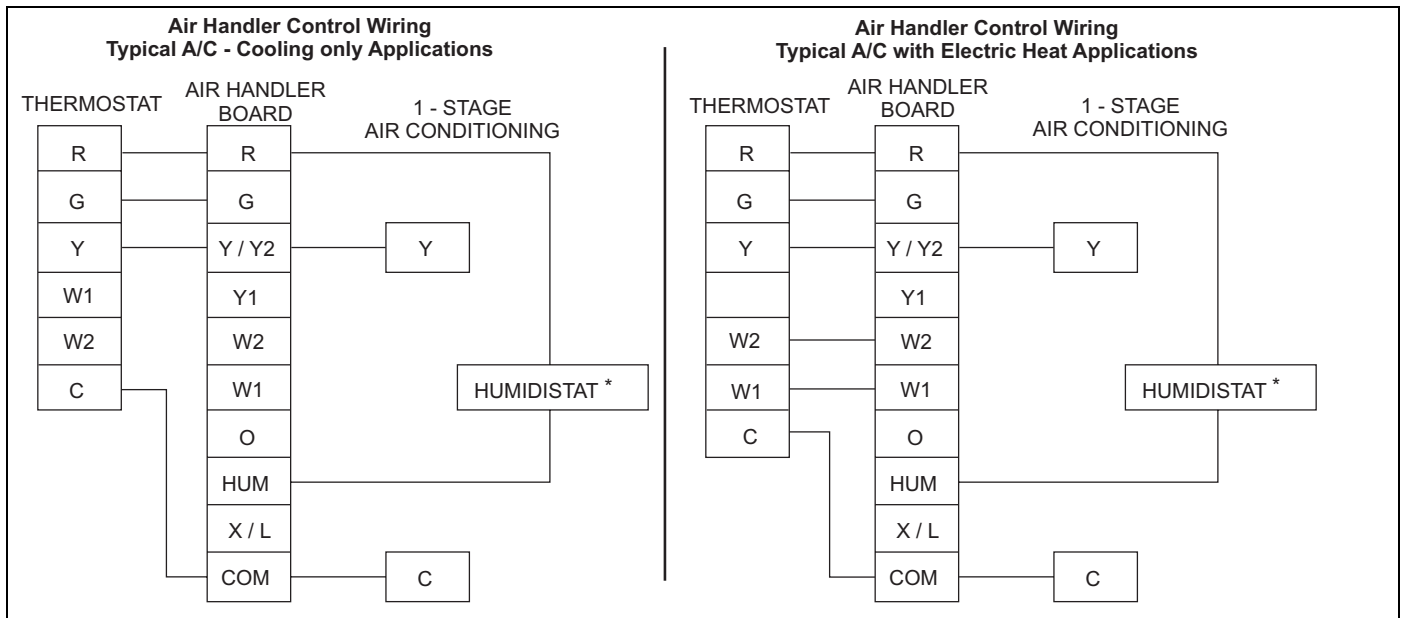

* Optional dehumidification humidistat switch contacts open on humidity rise.

NOTES:

1. “Y/Y2” Terminal on air handler control board must be connected for full CFM and applications requiring 60 second blower off delay for SEER enhancement.
2. Remove humidistat jumper on air handler control board.
3. For heat pump applications - set MODE jumper on air handler control board to the HP position.
4. To change quantity of heat during HP defrost cycle - reverse connections at W1 and W2 on air handler control board.

TWO-STAGE COOLING WIRING

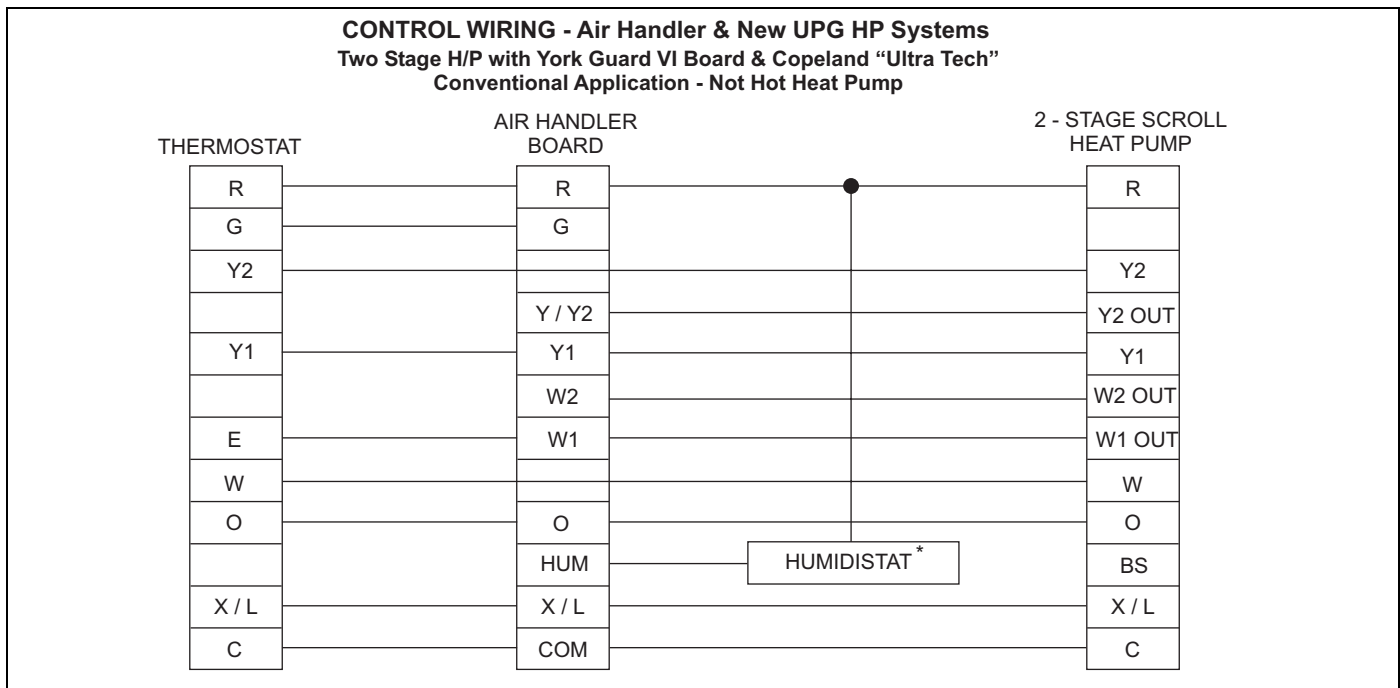

NOTES:

1. "Y/Y2" Terminal on air handler control board must be connected for full CFM and applications requiring 60 second blower off delay for SEER enhancement.
2. Remove humidistat jumper on air handler control board.
3. For heat pump applications - set MODE jumper on air handler control board to the HP position.
4. To change quantity of heat during HP defrost cycle - reverse connections at W1 and W2 on air handler control board.

TYPICAL APPLICATIONS

