



# Fantech

Your Ventilation Solutions Company



## FEATURES

- Compact design
- Backward curved blade motors
- Electrostatic filters (washable)
- Aluminum heat recovery core
- External screw type dry contacts
- Improved core guide channels for easy removal of core

## OPTIONAL CONTROLS

- EDF 1 – On/Off, Low, High Speed Operation and 20 min. On/40 min. Off Cycle Timer
- RTS 3 – Intermittent Bathroom Timer with Settings for 20/40/60 Minutes of High Speed Boost
- EDF 5 – Digital multi-function wall control with recirculation
- EDF 2 – Digital multi-function wall control
- MDEH 2 – Mechanical low voltage dehumidistat with On/Off switch
- MDEH 1 – Mechanical low voltage dehumidistat
- RTS 2 – 15 Minute pushbutton timer
- AQS 1 – Air quality sensor

## WARRANTY

- 7 year on motors
- 5 year on parts
- Lifetime on core (limited)

Distributed by:

## Heat Recovery Ventilator

Model VHR 1404

## SPECIFICATIONS

**CASE** 24 gauge galvanized steel. Powder coated finish, antique white. Insulated with 1" (25 mm) foil-faced high density polystyrene foam to prevent condensation and meet the requirements of the Underwriters Laboratories 94HF.

**MOTORS** Two (2) German-engineered, factory-balanced ebm™ motors with backward curved blades. Motors come with permanently lubricated sealed bearings guarantee long life and maintenance-free operation. Seven (7) year warranty.

**FILTERS** Two (2) Washable Electrostatic Panel Type Air Filters, 8.5" (216mm) x 15" (380mm) x 0.125" (3mm).

**CORE** A aluminum heat recovery core configured for an efficient cross-flow ventilation. Core is 9" x 9" (229 x 229 mm) with a 15" (380 mm) depth. Cores are manufactured to withstand extreme temperature variations.

**CONTROLS** External three (3) position (Low/Stand By/Medium) rocker switch that will offer continuous ventilation. Fantech offers a variety of external controls. (see optional controls)

**DEFROST** A preset defrost sequence is activated at an outdoor air temperature of 23°F (-5°C) and lower. During the defrost sequence, the supply blower shuts down & the exhaust blower switches into high speed to maximize the effectiveness of the defrost strategy. The unit then returns to normal operation, and continues cycle.

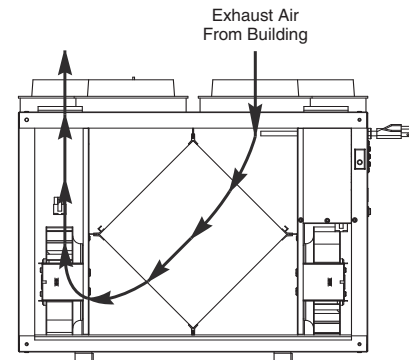

**INSTALLATION** Unit is typically hung by using installation kit supplied with unit. Mounting bolts provided on top four (4) corners of unit.

**SERVICEABILITY** Core, filters, motors and drain pan can be easily serviced through latched access door. Core conveniently slides out with ease on an improved railing system.

**Dimensions & Airflow** - All units feature three foot plug-in power cord with 3-prong plug.

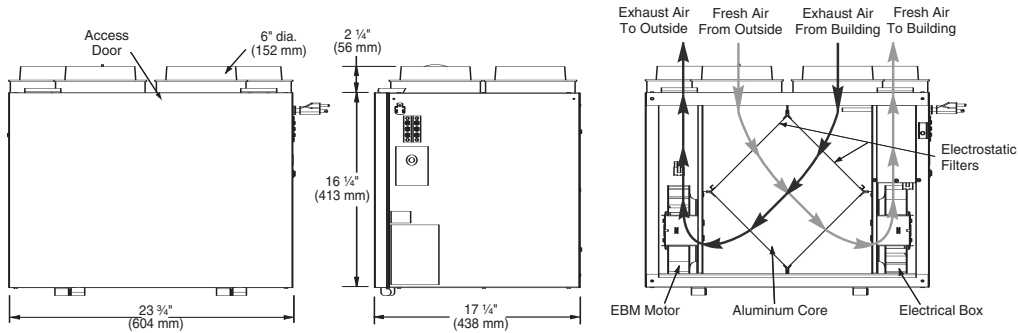

**Ventilation Performance**

EXT. STATIC PRESSURE		NET SUPPLY AIR FLOW		GROSS AIR FLOW			
				SUPPLY		EXHAUST	
Pa	in wg	L/s	cfm	L/s	cfm	L/s	cfm
25	0.1	85	181	87	184	84	180
50	0.2	80	170	182	174	79	169
75	0.3	75	159	176	162	75	159
100	0.4	70	149	71	151	68	146
125	0.5	65	138	66	141	64	136
150	0.6	60	128	61	130	59	125
175	0.7	55	116	56	119	54	114
200	0.8	49	104	50	106	47	100
225	0.9	43	91	43	92	41	87
250	1.0	36	77	37	79	35	75
275	1.1	30	63	30	64	29	61
300	1.2	23	49	24	50	22	46

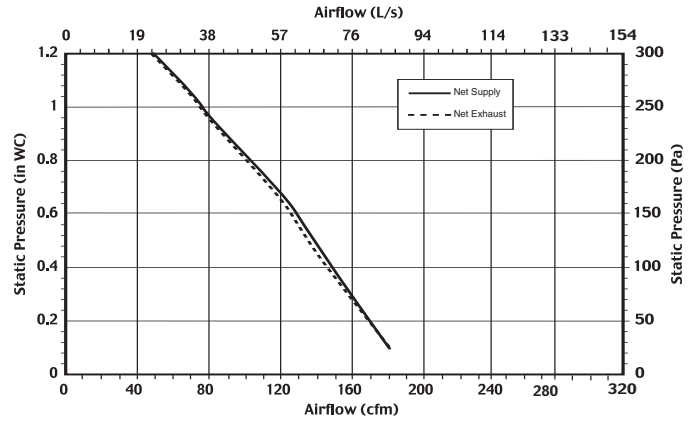

**Energy Performance**

	SUPPLY TEMPERATURE		NET AIRFLOW		POWER CONSUMED WATTS	SENSIBLE RECOVERY EFFICIENCY	APPARENT SENSIBLE EFFEC-TIVENESS	LATENT RECOVERY/MOISTURE TRANSFER
	°C	°F	L/s	cfm				
Heating	0	32	31	65	108	62	77	0.06
	0	32	55	117	154	62	74	0.07
	0	32	90	191	246	60	71	0.00
	-25	-13	59	126	141	64	81	0.01

**Specifications and Ratings**

- Model: VHR 1404
- Total assembled weight: 45 lbs
- Cabinet: 24 ga. steel w/ powder coat finish
- Motors: ebm motor w/backward curved blades
- Filters: 2 washable electrostatic filters  
8.5" (216mm) x 15" (380mm) x 0.125" (3mm)
- Insulated with 1" (25 mm) foil-faced high density polystyrene foam to prevent condensation and meet the requirements of the Underwriters Laboratories 94HF.
- Core: Aluminum  
9" (229mm) x 9" (229 mm) x 15" (380 mm)
- Supply & exhaust ducts: 6" (152.4mm)
- Mounting: Suspended by chains & hooks
- Electrical requirements:  
Volts Frequency Amps Watts High Speed  
120V 60Hz 1.3A 150W
- 3' plug-in power cord w/ 3-prong plug

**Contacts**

Submitted by: \_\_\_\_\_ Date: \_\_\_\_\_

Qty: \_\_\_\_\_ Model #: \_\_\_\_\_

Comments: \_\_\_\_\_

Project #: \_\_\_\_\_

Location: \_\_\_\_\_

Architect: \_\_\_\_\_

Engineer: \_\_\_\_\_

Contractor: \_\_\_\_\_



United States  
1712 Northgate Blvd.,  
Sarasota, FL. 34234  
(T) 1.800.747.1762  
(F) 1.800.487.9915  
(T) 1.941.309.6000  
(F) 1.941.309.6099  
www.fantech.net  
info@fantech.net

Canada  
50 Kanalfakt Way,  
Bouctouche, NB E4S 3M5  
(T) 1.800.565.3548  
(F) 1.877.747.8116  
(T) 1.506.743.9500  
(F) 1.506.743.9600  
www.fantech.ca  
info@fantech.ca



Article #: 403792  
Rev Date: 051507