



TECHNICAL GUIDE

Echelon

SPLIT-SYSTEM HEAT PUMPS

18 SEER – R-410A

MODELS:

HC8B024 THRU 060

(2 THRU 5 NOMINAL TONS)



Due to continuous product improvement, specifications are subject to change without notice.

Visit us on the web at www.york.com

Additional rating information can be found at www.ahridirectory.org

DESCRIPTION

The HC8B Series unit is the outdoor part of a versatile heat pump system. It is designed to be custom matched with one of our complete line of evaporator sections, each designed to serve a specific function. Matching air handlers are available for upflow, downflow, and horizontal left or right application to provide a complete system. Electric heaters are available if required. Add-on coils are available for use with upflow, downflow, or horizontal furnaces. Field installed accessories are available as needed.

WARRANTY

5-year limited parts warranty.

10-year limited compressor warranty.

Premium System Warranty - Limited lifetime compressor and 10-year parts when matched with an approved Coleman Echelon furnace or UPG air handler and coil.

FEATURES

- **Superior Coil Protection** – A PVC coated steel coil guard completely protects coil from debris and other large damaging material while a polymer mesh further protects the coil against smaller particles.
- **Isolated Compressor Compartment** – A molded composite bulkhead isolates the compressor from the rest of the unit reducing sound and vibration.
- **Protected Compressors** – Each compressor is protected against high and low pressure as well as excessive temperature. This is accomplished by the simultaneous operation of a high pressure relief valve and temperature sensors which protect the compressor if undesirable conditions occur.
- **Environmentally Friendly Refrigerant** – Next generation refrigerant R-410A delivers environmentally friendly performance, with zero ozone depletion.
- **Durable Finish** – Automotive quality finish provides the ultimate protection from harmful U.V. rays as well as rust creep ensuring long-lasting high quality appearance. A powder-paint topcoat is applied over a baked-on primer, using a galvanized, zinc coated steel base material. The result is a finish that has been proven in testing to provide 33% greater durability than conventional powder-coat finishes.
- **Lower Installed Cost** – Designed to provide enhanced installability by featuring a slide-down control compartment allowing easy access to control components along with angled service valves to reduce overall installation time and cost.
- **Low Operating Sound Levels** – A fan design boasting technology adapted from aeronautic and defense engineering provides for whisper quiet operation by allowing airflow to flow smoothly and efficiently across the fan tips.
- **Filter-Drier** – A factory installed, solid core liquid line filter-drier filters harmful debris and moisture from the system.
- **Easy Service Access** – A full end, full service, access panel with handle makes for easy entry to internal components.
- **Long Lasting Operation** – Strong and durable composite base pan provides added strength while resisting rust and corrosion as well as reducing sound and vibration.
- **WhisperDrive™ system** - The swept-wing fan, composite base pan, isolated compressor compartment and two-stage compressor are engineered as a system to reduce overall sound to a mere whisper.
- **Complete System Control** – All models utilize the exclusive micro-processor based, on-demand, defrost control system. This system provides optimal comfort, efficiency, and constant monitoring of the entire system for reliable operation. defrost cycles occur only when necessary. an adjustable balance point insures supplemental heat is brought on only when required to meet the space load, for optimum efficiency and reliability.
- In the event improper operating conditions occur (high temperature and/or high pressure), the unit will automatically shut down to protect the refrigeration system, and switch to back-up heat. On-board diagnostic LED's guide the technician to the source of the problem, and an output signal from the control to the thermostat will alert the homeowner. The control also features non-volatile memory, which preserves trouble codes in the event of power loss. An anti-short cycle timer extends the life of the compressor by preventing short-cycling.
- **Agency Listed** - U.L. and C.U.L. listed - approved for outdoor application. The unit is certified in accordance with the Unitary Small Equipment certification program, which is based on ARI Standard 210/240.

Physical and Electrical Data

MODEL		HC8B024F1	HC8B036F1	HC8B048F1	HC8B060F1
Unit Supply Voltage		208-230V, 1 ϕ , 60Hz			
Normal Voltage Range ¹		187 to 252			
Minimum Circuit Ampacity		18.2	23.6	29.2	34.8
Max. Overcurrent Device Amps ²		30	40	50	60
Min. Overcurrent Device Amps ³		20	25	30	35
Multi-stage Compressor		Yes	Yes	Yes	Yes
Compressor Type		Scroll	Scroll	Scroll	Scroll
Compressor Amps	Rated Load	12.3	16.6	21.1	25.6
	Locked Rotor	52	82	96	118
Crankcase Heater		No	No	No	No
Fan Motor Amps	Rated Load	2.8	2.8	2.8	2.8
Fan Diameter Inches		24	24	24	24
Fan Motor	Rated HP	1/3	1/3	1/3	1/3
	Nominal RPM	685	685	685	685
	Nominal CFM	2,940	2,666	3,376	3,332
Coil	Face Area Sq. Ft.	23.58	23.58	23.58	23.58
	Rows Deep	2	2	2	2
	Fins / Inch	16	16	14	14
Liquid Line Set OD (Field Installed)		3/8	3/8	3/8	3/8
Vapor Line Set OD (Field Installed)		3/4	3/4	7/8	7/8
Unit Charge (Lbs. - Oz.) ⁴		14 - 12	12 - 7	12 - 13	14 - 8
Charge Per Foot, Oz.		0.62	0.62	0.67	0.67
Operating Weight Lbs.		275	275	280	315

1. Rated in accordance with ARI Standard 110, utilization range "A".
2. Dual element fuses or HACR circuit breaker. Maximum allowable overcurrent protection.
3. Dual element fuses or HACR circuit breaker. Minimum recommended overcurrent protection .
4. The Unit Charge is correct for the outdoor unit, matched indoor coil and 15 feet of refrigerant tubing. For tubing lengths other than 15 feet, add or subtract the amount of refrigerant, using the difference in length multiplied by the per foot value.

All dimensions are in inches. They are subject to change without notice. Certified dimensions will be provided upon request.

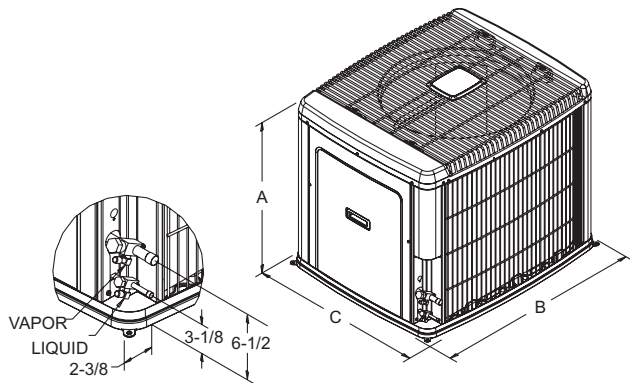

Unit Model	Dimensions (Inches)			Refrigerant Connection Service Valve Size	
	A	B	C	Liquid	Vapor
024	39-1/2	42	34	3/8"	3/4"
036	39-1/2	42	34		
048	39-1/2	42	34		7/8"
060	39-1/2	42	34		

Additional R-410A Charge / TXV Size for Various Matched Systems

Outdoor Unit	HC8B024F1	HC8B036F1	HC8B048F1	HC8B060F1
Approved System Thermal Expansion Valve ¹	1TVM(903/4G1)	1TVM(906/4K1)	1TVM(906/4K1)	1TVM(906/4K1)
Factory R-410A Charge, lbs-oz	14 - 12	12 - 7	12 - 13	14 - 8
Indoor Coil²	TXV Kit³ - Additional Charge, Oz			
FC/MC/PC43B	0	0	-	-
FC/MC/PC43C	-	0	-	-
FC/MC/PC48C	-	0	0	-
FC/MC/PC48D	+4	0	0	-
FC/PC60C	+8	+4	+4	0
FC/MC/PC60D	+8	+4	+4	0
FC/MC62D	-	+8	+8	+4
HC42	-	0	-	-
AV36	0	0	-	-
AV/SV48	-	+4	0	-
AV/SV60	-	-	+4	0

FOOTNOTES:

1. Systems matched with furnace or air handlers not equipped with blower-off delays may require blower Time Delay Kit 2FD06700224.
2. PC coils cannot be used in downflow or horizontal applications. FC coils cannot be used in horizontal applications.
3. A TXV kit must be used with these coils to obtain system performance.

Note: If a TXV is factory installed on the coil, it must be replaced with the listed TXV.

PROCEDURES:

1. Unit factory charge listed on the unit nameplate includes refrigerant for the condenser, the smallest evaporator and 15 feet of interconnecting line tubing.
2. Verify the TXV and additional charge required for specific evaporator coil in the system using the above table.
3. Additional charge for the amount of interconnecting line tubing greater than 15 feet at the rate specified in the Physical and Electrical Data Table.
4. Permanently mark the unit nameplate with the total system charge. Total System Charge = Base Charge (as shipped) + adder for evaporator + adder for line set.

COOLING CAPACITY - With Air Handler Coils

UNIT MODEL	AIR HANDLER		COIL ¹ MODEL	COOLING					
	MODEL	W		STAGE	RATED CFM	NET MBH		SEER	EER
						TOTAL	SENSIBLE		
18 SEER HP WITH MV - VARIABLE SPEED									
HC8B024F1	MV12B	17	FC/MC43B	1	645	18.2	13.5	16.40	14.00
				2	835	23.6	18.8		13.60
	MV12D	24	FC/MC48D	1	645	18.5	14.0	17.00	14.50
				2	835	24.0	19.5		14.00
	MV12D	24	FC/MC60D	1	645	18.5	14.0	17.00	14.50
				2	835	24.0	19.5		14.00
HC8B036F1	MV16C	21	FC/MC43C	1	775	24.8	18.2	17.10	14.20
				2	1200	35.4	26.6		13.10
	MV16C	21	FC/MC48C	1	775	25.0	18.6	17.30	14.40
				2	1200	35.8	26.8		13.35
	MV12D	24	FC/MC48D	1	845	24.8	18.0	17.35	14.45
				2	1245	35.2	26.2		13.35
	MV12D	24	FC/MC60D	1	845	24.8	18.3	17.50	14.60
				2	1245	35.4	26.4		13.35
	MV12D	24	FC/MC62D	1	845	25.6	19.7	18.00	15.00
				2	1245	36.0	27.8		13.35
HC8B048F1	MV16C	21	FC/MC48C	1	1000	33.4	25.0	16.65	13.60
				2	1600	46.5	35.6		12.20
	MV20D	24	FC/MC48D	1	1045	33.4	25.0	16.30	13.35
				2	1570	46.5	35.6		12.05
	MV20D	24	FC/MC60D	1	1045	33.0	25.0	16.20	13.25
				2	1570	47.0	36.4		12.25
	MV20D	24	FC/MC62D	1	1045	33.8	25.8	17.00	13.90
				2	1570	47.0	36.6		12.50
HC8B060F1	MV20D	24	FC/MC60D	1	1175	39.5	27.6	14.75	12.20
				2	1820	57.0	42.0		11.35
	MV20D	24	FC/MC62D	1	1175	41.0	29.8	15.50	12.80
				2	1820	57.0	43.0		11.80
18 SEER HP WITH AV/SV - VARIABLE SPEED									
HC8B024F1	AV36	21	-	1	600	18.1	13.5	16.65	14.20
				2	765	23.4	18.5		13.70
HC8B036F1	AV36	21	-	1	830	25.2	19.0	17.45	14.55
				2	1270	35.4	27.4		13.40
	AV/SV48	24	-	1	910	25.8	20.4	17.65	14.70
				2	1190	35.4	27.0		13.60
HC8B048F1	AV/SV48	24	-	1	1135	34.0	26.4	16.75	13.70
				2	1610	47.0	36.4		12.30
	AV/SV60	24	-	1	1085	33.6	26.0	16.55	13.55
				2	1655	47.0	37.0		12.30
HC8B060F1	AV/SV60	24	-	1	1145	40.5	29.0	15.15	12.50
				2	1765	56.5	41.5		11.50

Rated in accordance with DOE test procedures (Federal Register 12-27-79 and 3-18-88) and ARI Standards 210.

Cooling MBH based on 80°F entering air temperature, 50% RH, and rated air flow.

EER (Energy Efficiency Ratio) is the total cooling output in BTU's at 95°F outdoor ambient divided by the total electric power in watt-hours at those conditions.

SEER (Seasonal Energy Efficiency Ratio) is the total cooling output in BTU's during a normal annual usage period for cooling divided by the total electric power input in watt-hours during the same period.

1. MC coils available with a factory installed horizontal drain pan. See price pages for specific model number.

COOLING CAPACITY - HC8B024F1 With Variable Speed Furnaces

VARIABLE SPEED FURNACE MODEL	COIL MODEL ¹	W	COOLING					
			STAGE	RATED CFM	NET MBH		SEER	EER
					TOTAL	SENSIBLE		
1 PH 18 SEER AC WITH - VARIABLE SPEED²								
FC9(C,V)*B12	FC/MC/PC43B	17	1	560	18.0	12.9	16.60	14.10
			2	820	23.6	18.9		13.30
C*(8,L)C*A12	FC/MC/PC30A	14	1	590	17.9	13.0	16.20	13.90
			2	805	23.0	18.2		13.30
C*(8,L)C*B12	FC/MC/PC30B	17	1	565	17.8	12.8	16.40	14.10
			2	815	23.2	18.3		13.50
C*9C*B12	FC/MC/PC30B	17	1	565	17.8	12.7	16.20	13.90
			2	790	23.0	18.2		13.20
C*(8,L)C*A12	FC/MC/PC32A	14	1	550	17.4	12.4	15.70	13.60
			2	775	23.2	18.1		13.20
C*(8,L)C*B12	FC/MC/PC35B	17	1	515	17.4	12.1	15.80	13.70
			2	760	23.0	18.0		13.30
C*9C*B12	FC/MC/PC35B	17	1	550	17.4	12.5	15.90	13.70
			2	815	23.4	18.5		13.30
C*(8,L)C*A12	FC/MC/PC36A	14	1	595	17.7	13.0	16.40	13.80
			2	805	23.4	18.4		13.50
C*(8,L)C*B12	FC/MC/PC36B	17	1	525	17.6	12.3	16.00	13.90
			2	765	23.0	18.0		13.50
C*9C*B12	FC/MC/PC36B	17	1	590	17.7	13.0	16.30	13.90
			2	815	23.4	18.4		13.50
C*(8,L)C*A12	FC/MC/PC37A	14	1	585	18.0	13.0	16.20	13.90
			2	805	23.4	18.7		13.30
C*(8,L)C*B12	FC/MC/PC43B	17	1	515	17.5	12.2	16.20	13.90
			2	760	23.2	18.3		13.50
C*9C*B12	FC/MC/PC43B	17	1	550	17.8	12.6	16.30	14.00
			2	800	23.4	18.7		13.40
C*(8,L)C*A12	HC30	14	1	550	17.5	12.4	15.80	13.60
			2	775	22.8	17.9		13.10
C*(8,L)C*A12	HD36	14	1	595	17.6	12.4	15.90	13.70
			2	805	23.0	17.7		13.20
C*(8,L)C*B12	HD36	17	1	515	17.1	11.7	15.50	13.50
			2	760	22.6	17.2		13.20
C*9C*B12	HD36	17	1	590	17.6	12.4	15.80	13.70
			2	815	23.0	17.7		13.30
C*(8,L)C*A12	UC30A	14	1	590	18.0	13.1	16.10	14.00
			2	805	23.2	18.5		13.40
C*(8,L)C*B12	UC30B	17	1	565	17.9	12.9	16.50	14.20
			2	815	23.4	18.5		13.60
C*9C*B12	UC30B	17	1	565	17.8	12.8	16.30	14.00
			2	790	23.2	18.5		13.40
C*(8,L)C*A12	UC36A	14	1	595	17.7	12.9	16.10	13.90
			2	805	23.2	18.5		13.40
C*(8,L)C*B12	UC36B	17	1	525	17.5	12.2	16.00	13.80
			2	765	23.0	18.0		13.50
C*9C*B12	UC36B	17	1	590	17.7	12.9	16.10	13.90
			2	815	23.2	18.5		13.40
G*9V*A12	FC/MC/PC30A	14	1	625	17.8	13.3	15.80	13.60
			2	800	23.2	18.2		13.10
G*9V*B12	FC/MC/PC30B	17	1	565	17.8	12.7	16.20	13.90
			2	790	23.0	18.2		13.20

For Notes See Page 6.

COOLING CAPACITY - HC8B024F1 With Variable Speed Furnaces (Continued)

VARIABLE SPEED FURNACE MODEL	COIL MODEL ¹	W	COOLING					
			STAGE	RATED CFM	NET MBH		SEER	EER
					TOTAL	SENSIBLE		
1 PH 18 SEER AC WITH - VARIABLE SPEED²								
G*9V*A12	FC/MC/PC32A	14	1	625	17.9	13.3	15.70	13.70
			2	800	23.2	18.3		12.90
G*9V*B12	FC/MC/PC35B	17	1	550	17.4	12.5	15.90	13.70
			2	815	23.4	18.5		13.30
G*9V*A12	FC/MC/PC36A	14	1	625	18.0	13.3	15.90	13.70
			2	800	23.2	18.3		13.20
G*9V*B12	FC/MC/PC36B	17	1	590	17.7	13.0	16.30	13.90
			2	815	23.4	18.4		13.50
G*9V*A12	FC/MC/PC37A	14	1	535	17.6	12.4	15.80	13.60
			2	800	23.4	18.6		13.20
G*9V*B12	FC/MC/PC43B	17	1	550	17.8	12.6	16.30	14.00
			2	800	23.4	18.7		13.40
G*9V*A12	HC30	14	1	625	17.9	13.2	15.60	13.70
			2	800	23.0	18.1		13.00
G*9V*A12	HD36	14	1	625	17.6	12.6	15.50	13.40
			2	800	22.8	17.5		13.00
G*9V*B12	HD36	17	1	590	17.6	12.4	15.80	13.70
			2	815	23.0	17.7		13.30
G*9V*A12	UC30A	14	1	625	18.0	13.4	15.80	13.70
			2	800	23.2	18.4		13.20
G*9V*B12	UC30B	17	1	565	17.8	12.8	16.30	14.00
			2	790	23.2	18.5		13.40
G*9V*A12	UC36A	14	1	625	17.8	13.1	15.70	13.60
			2	800	23.0	18.1		13.00
G*9V*B12	UC36B	17	1	590	17.7	12.9	16.10	13.90
			2	815	23.2	18.5		13.40

1. MC coils available with a factory installed horizontal drain pan. See price pages for specific model number.
2. Variable speed furnaces have B.O.D (Blower on Delay) standard.

COOLING CAPACITY - HC8B036F1 With Variable Speed Furnaces

VARIABLE SPEED FURNACE MODEL	COIL MODEL ¹	W	COOLING					
			STAGE	RATED CFM	NET MBH		SEER	EER
					TOTAL	SENSIBLE		
1 PH 18 SEER AC WITH - VARIABLE SPEED²								
(F,L)C8V*B16	FC/MC/PC43B	17	1	750	24.6	18.1	17.00	14.20
			2	1200	35.2	26.4		13.40
(F,L)C8V*C16	FC/MC/PC43C	21	1	640	23.8	16.6	16.90	14.05
			2	1200	35.4	26.6		13.45
(F,L)C8V*C20	FC/MC/PC43C	21	1	780	24.6	18.3	17.00	14.15
			2	1200	35.2	26.4		13.50
FC9(C,V)*B12	FC/MC/PC43B	17	1	770	24.6	18.4	16.90	14.05
			2	1185	35.0	26.2		12.90
FC9(C,V)*C16	FC/MC/PC43C	21	1	770	24.8	18.2	17.40	14.50
			2	1175	35.0	26.4		13.35
FC9(C,V)*C20	FC/MC/PC43C	21	1	790	24.8	18.4	17.10	14.20
			2	1195	35.2	26.4		13.30
(F,L)C8V*C16	FC/MC/PC48C	21	1	640	24.0	16.9	17.10	14.25
			2	1200	35.6	26.8		13.65
(F,L)C8V*C20	FC/MC/PC48C	21	1	780	24.8	18.5	17.20	14.30
			2	1200	35.4	26.6		13.60
FC9(C,V)*C16	FC/MC/PC48C	21	1	770	25.0	18.4	17.50	14.60
			2	1175	35.4	26.6		13.45

For Notes See Page 11.

COOLING CAPACITY - HC8B036F1 With Variable Speed Furnaces (Continued)

VARIABLE SPEED FURNACE MODEL	COIL MODEL ¹	W	COOLING					
			STAGE	RATED CFM	NET MBH		SEER	EER
					TOTAL	SENSIBLE		
1 PH 18 SEER AC WITH - VARIABLE SPEED²								
FC9(C,V)*C20	FC/MC/PC48C	21	1	790	25.0	18.6	17.20	14.30
			2	1195	35.4	26.6		15.00
FC9(C,V)*D20	FC/MC/PC48D	24	1	775	25.0	18.6	17.30	14.40
			2	1220	35.6	27.0		13.50
(F,L)C8V*C16	FC/PC60C	21	1	640	24.2	17.1	17.20	14.35
			2	1200	35.4	27.0		13.55
(F,L)C8V*C20	FC/PC60C	21	1	780	25.0	18.8	17.30	14.40
			2	1200	35.2	27.0		13.45
FC9(C,V)*C16	FC/PC60C	21	1	770	25.0	18.7	17.50	14.55
			2	1175	35.0	26.6		13.30
FC9(C,V)*C20	FC/PC60C	21	1	790	25.0	18.9	17.30	14.40
			2	1195	35.0	26.8		13.25
FC9(C,V)*D20	FC/MC/PC60D	24	1	775	25.0	18.7	17.30	14.40
			2	1220	35.2	27.0		13.40
(F,L)C8V*C20	FC/MC62D	21	1	780	24.8	18.5	17.30	14.40
			2	1200	35.6	27.2		13.75
FC9(C,V)*C20	FC/MC62D	21	1	790	25.0	18.7	17.30	14.40
			2	1195	35.8	27.2		13.55
FC9(C,V)*D20	FC/MC62D	24	1	775	25.0	18.7	17.40	14.45
			2	1220	36.0	27.4		13.65
(F,L)C8V*C16	HC42	21	1	640	23.8	16.8	16.90	14.05
			2	1200	35.2	26.4		13.45
(F,L)C8V*C20	HC42	21	1	780	24.6	18.3	17.10	14.20
			2	1200	35.0	26.2		13.45
FC9(C,V)*C16	HC42	21	1	770	24.8	18.2	17.40	14.50
			2	1175	35.2	26.4		13.40
FC9(C,V)*C20	HC42	21	1	790	25.0	18.5	17.00	14.20
			2	1195	35.2	26.4		13.30
C*(8,L)C*B12	FC/MC/PC35B	17	1	745	24.4	17.8	16.70	14.00
			2	1220	34.4	25.8		12.00
C*(8,L)C*C16	FC/MC/PC35C	21	1	815	24.8	18.6	17.00	14.20
			2	1235	34.8	26.4		12.60
C*(8,L)C*C20	FC/MC/PC35C	21	1	945	25.4	20.6	16.90	14.10
			2	1170	34.4	25.8		12.70
C*9C*B12	FC/MC/PC35B	17	1	810	24.6	18.4	16.50	13.90
			2	1190	34.4	26.2		12.10
C*9C*C16	FC/MC/PC35C	21	1	790	24.6	18.3	17.00	14.10
			2	1215	34.6	26.2		12.40
C*9C*C20	FC/MC/PC35C	21	1	760	24.4	18.0	16.70	14.10
			2	1295	34.6	26.8		12.10
C*(8,L)C*A12	FC/MC/PC36A	14	1	815	24.4	18.3	16.60	13.80
			2	1190	33.8	25.0		11.90
C*(8,L)C*B12	FC/MC/PC36B	17	1	745	24.2	17.7	17.00	14.00
			2	1220	34.0	25.4		12.10
C*(8,L)C*C16	FC/MC/PC36C	21	1	805	24.6	18.4	17.00	14.20
			2	1235	34.2	25.2		12.40
C*(8,L)C*C20	FC/MC/PC36C	21	1	800	24.6	18.3	17.00	14.30
			2	1240	34.2	25.4		12.50
C*9C*B12	FC/MC/PC36B	17	1	800	24.4	18.2	16.60	13.90
			2	1165	34.0	25.2		12.20
C*9C*C16	FC/MC/PC36C	21	1	915	25.0	19.4	16.80	14.10
			2	1185	34.2	25.4		12.50
C*9C*C20	FC/MC/PC36C	21	1	760	24.4	17.8	17.00	14.10
			2	1285	34.4	26.4		12.20

For Notes See Page 11.

COOLING CAPACITY - HC8B036F1 With Variable Speed Furnaces (Continued)

VARIABLE SPEED FURNACE MODEL	COIL MODEL ¹	W	COOLING					
			STAGE	RATED CFM	NET MBH		SEER	EER
					TOTAL	SENSIBLE		
1 PH 18 SEER AC WITH - VARIABLE SPEED²								
C*(8,L)C*A12	FC/MC/PC37A	14	1	655	24.0	17.0	16.70	13.90
			2	980	33.6	24.0		12.30
C*(8,L)C*B12	FC/MC/PC42B	17	1	760	24.8	18.3	17.20	14.40
			2	1175	34.6	26.0		12.60
C*(8,L)C*C16	FC/MC/PC42C	21	1	825	25.0	19.0	17.50	14.50
			2	1205	35.0	26.4		12.90
C*(8,L)C*C20	FC/MC/PC42C	21	1	735	24.6	18.0	17.40	14.40
			2	1170	35.0	26.0		13.00
C*9C*B12	FC/MC/PC42B	17	1	800	25.0	18.7	16.90	14.10
			2	1195	34.4	26.0		12.00
C*9C*C16	FC/MC/PC42C	21	1	780	24.8	18.5	17.20	14.30
			2	1205	34.8	26.0		12.70
C*9C*C20	FC/MC/PC42C	21	1	770	25.0	18.5	17.20	14.40
			2	1315	35.2	27.2		12.50
C*(8,L)C*B12	FC/MC/PC43B	17	1	745	24.6	18.1	17.00	14.20
			2	1210	34.6	26.2		12.20
C*(8,L)C*C16	FC/MC/PC43C	21	1	800	25.0	18.8	17.30	14.50
			2	1205	35.2	26.6		12.80
C*(8,L)C*C20	FC/MC/PC43C	21	1	745	24.8	18.1	17.30	14.50
			2	1190	35.2	26.6		12.90
C*9C*B12	FC/MC/PC43B	17	1	815	25.0	18.8	17.00	14.20
			2	1200	34.6	26.2		12.20
C*9C*C16	FC/MC/PC43C	21	1	815	25.2	18.9	17.10	14.30
			2	1240	35.0	26.8		12.40
C*9C*C20	FC/MC/PC43C	21	1	780	25.0	18.5	17.30	14.40
			2	1200	35.0	26.6		12.70
C*(8,L)C*C16	FC/MC/PC48C	21	1	810	24.4	18.7	17.30	14.30
			2	1210	34.8	26.6		12.90
C*(8,L)C*C20	FC/MC/PC48C	21	1	720	24.2	17.8	17.20	14.20
			2	1155	34.8	26.2		13.00
C*9C*C16	FC/MC/PC48C	21	1	780	24.4	18.7	17.30	14.30
			2	1195	34.8	26.6		12.70
C*9C*C20	FC/MC/PC48C	21	1	745	24.2	18.0	17.00	14.20
			2	1305	35.0	27.6		12.40
C*(8,L)C*C16	FC/PC60C	21	1	810	24.6	18.9	17.30	14.40
			2	1195	34.8	26.8		13.00
C*(8,L)C*C20	FC/PC60C	21	1	800	24.4	18.6	17.30	14.30
			2	1215	34.8	27.0		12.90
C*9C*C16	FC/PC60C	21	1	810	24.2	18.7	17.00	14.00
			2	1235	34.4	26.8		12.40
C*9C*C20	FC/PC60C	21	1	770	24.2	18.3	17.10	14.20
			2	1305	35.0	27.8		12.50
C*9C*D20	FC/MC/PC60D	24	1	830	24.4	19.0	17.10	14.20
			2	1225	34.8	27.0		12.80
C*9C*D20	FC/MC62D	24	1	835	25.6	19.5	17.50	14.70
			2	1235	35.8	27.4		13.00
C*(8,L)C*C16	HC42	21	1	800	25.2	18.8	17.30	14.50
			2	1205	35.0	26.6		12.80
C*(8,L)C*C20	HC42	21	1	745	24.8	18.1	17.30	14.50
			2	1190	35.0	26.6		12.90
C*9C*C16	HC42	21	1	815	25.2	18.9	17.10	14.30
			2	1240	34.8	26.4		12.40
C*9C*C20	HC42	21	1	780	25.0	18.5	17.20	14.40
			2	1200	35.0	26.6		12.70

For Notes See Page 11.

COOLING CAPACITY - HC8B036F1 With Variable Speed Furnaces (Continued)

VARIABLE SPEED FURNACE MODEL	COIL MODEL ¹	W	COOLING					
			STAGE	RATED CFM	NET MBH		SEER	EER
					TOTAL	SENSIBLE		
1 PH 18 SEER AC WITH - VARIABLE SPEED²								
C*(8,L)C*B12	HD48	17	1	750	24.6	18.1	16.80	14.30
			2	1210	34.6	26.2		12.40
C*(8,L)C*C16	HD48	21	1	810	24.8	18.7	17.30	14.40
			2	1210	34.8	26.4		12.80
C*(8,L)C*C20	HD48	21	1	720	24.4	17.8	17.20	14.40
			2	1155	34.4	25.8		12.80
C*9C*B12	HD48	17	1	710	24.4	17.6	16.80	14.10
			2	1150	34.0	25.4		12.10
C*9C*C16	HD48	21	1	780	24.6	18.3	17.10	14.20
			2	1195	34.8	26.4		12.60
C*9C*C20	HD48	21	1	745	24.6	18.1	16.90	14.30
			2	1330	35.8	27.6		12.70
C*(8,L)C*A12	UC36A	14	1	815	24.4	18.3	16.50	13.80
			2	1190	33.6	25.0		11.80
C*(8,L)C*B12	UC36B	17	1	745	24.2	17.7	16.70	14.00
			2	1220	34.0	25.4		12.10
C*(8,L)C*C16	UC36C	21	1	805	24.6	18.4	17.00	14.20
			2	1235	34.0	25.2		12.40
C*(8,L)C*C20	UC36C	21	1	800	24.6	18.3	17.00	14.30
			2	1240	34.0	25.2		12.50
C*9C*B12	UC36B	17	1	800	24.4	18.2	16.50	13.90
			2	1165	33.8	25.2		12.20
C*9C*C16	UC36C	21	1	915	25.0	19.3	16.80	14.00
			2	1185	34.0	25.4		12.40
C*9C*C20	UC36C	21	1	760	24.2	17.8	16.80	14.10
			2	1285	34.4	26.4		12.20
C*(8,L)C*B12	UC42B	17	1	760	24.4	17.9	17.00	14.10
			2	1175	34.2	25.4		12.40
C*(8,L)C*C16	UC42C	21	1	825	24.6	18.6	17.20	14.30
			2	1205	34.6	25.8		12.80
C*(8,L)C*C20	UC42C	21	1	735	24.2	17.6	17.10	14.20
			2	1170	34.4	25.6		12.90
C*9C*B12	UC42B	17	1	800	24.4	18.2	16.60	13.90
			2	1195	34.0	25.4		11.90
C*9C*C16	UC42C	21	1	780	24.4	18.1	17.00	14.10
			2	1205	34.2	25.4		12.50
C*9C*C20	UC42C	21	1	770	24.4	18.0	17.00	14.10
			2	1300	34.8	26.6		12.40
C*(8,L)C*C16	UC48C	21	1	810	25.2	19.2	17.60	14.60
			2	1210	35.0	26.8		12.80
C*(8,L)C*C20	UC48C	21	1	720	24.6	18.1	17.40	14.50
			2	1155	34.8	26.4		12.90
C*9C*C16	UC48C	21	1	780	25.0	18.8	17.40	14.40
			2	1195	34.8	26.8		12.70
C*9C*C20	UC48C	21	1	755	24.8	18.4	17.20	14.30
			2	1330	35.6	28.0		12.50
C*(8,L)C*C16	UC60C	21	1	810	25.2	18.8	17.40	14.60
			2	1195	35.0	26.4		13.00
C*(8,L)C*C20	UC60C	21	1	800	25.2	18.8	17.40	14.60
			2	1215	35.0	26.4		12.90
C*9C*C16	UC60C	21	1	810	25.2	18.8	17.40	14.60
			2	1235	34.8	26.2		12.50
C*9C*C20	UC60C	21	1	770	24.8	18.3	17.20	14.30
			2	1325	35.4	27.6		12.60

For Notes See Page 11.

COOLING CAPACITY - HC8B036F1 With Variable Speed Furnaces (Continued)

VARIABLE SPEED FURNACE MODEL	COIL MODEL ¹	W	COOLING					
			STAGE	RATED CFM	NET MBH		SEER	EER
					TOTAL	SENSIBLE		
1 PH 18 SEER AC WITH - VARIABLE SPEED²								
C*9C*D20	UC60D	24	1	830	25.2	18.8	17.40	14.60
			2	1225	35.0	26.4		12.80
G*9V*B12	FC/MC/PC35B	17	1	810	24.6	18.4	16.50	13.90
			2	1190	34.4	26.2		12.10
G*9V*C16	FC/MC/PC35C	21	1	790	24.6	18.3	17.00	14.10
			2	1215	34.6	26.2		12.40
G*9V*C20	FC/MC/PC35C	21	1	760	24.4	18.0	16.70	14.10
			2	1295	34.6	26.8		12.10
G*9V*A12	FC/MC/PC36A	14	1	780	24.2	17.9	16.30	13.70
			2	1200	33.8	25.0		11.80
G*9V*B12	FC/MC/PC36B	17	1	800	24.4	18.2	16.60	13.90
			2	1165	34.0	25.2		12.20
G*9V*C16	FC/MC/PC36C	21	1	915	25.0	19.4	16.80	14.10
			2	1185	34.2	25.4		12.50
G*9V*C20	FC/MC/PC36C	21	1	760	24.4	17.8	17.00	14.10
			2	1285	34.4	26.4		12.20
G*9V*A12	FC/MC/PC37A	14	1	800	25.0	18.6	16.50	13.90
			2	1100	34.2	25.0		12.00
G*9V*B12	FC/MC/PC42B	17	1	800	25.0	18.7	16.90	14.10
			2	1195	34.4	26.0		12.00
G*9V*C16	FC/MC/PC42C	21	1	780	24.8	18.5	17.20	14.30
			2	1205	34.8	26.0		12.70
G*9V*C20	FC/MC/PC42C	21	1	770	25.0	18.5	17.20	14.40
			2	1315	35.2	27.2		12.50
G*9V*B12	FC/MC/PC43B	17	1	815	25.0	18.8	17.00	14.20
			2	1200	34.6	26.2		12.20
G*9V*C16	FC/MC/PC43C	21	1	815	25.2	18.9	17.10	14.30
			2	1240	35.0	26.8		12.40
G*9V*C20	FC/MC/PC43C	21	1	780	25.0	18.5	17.30	14.40
			2	1200	35.0	26.6		12.70
G*9V*C16	FC/MC/PC48C	21	1	780	24.4	18.7	17.30	14.30
			2	1195	34.8	26.6		12.70
G*9V*C20	FC/MC/PC48C	21	1	745	24.2	18.0	17.00	14.20
			2	1305	35.0	27.6		12.40
G*9V*C16	FC/PC60C	21	1	810	24.2	18.7	17.00	14.00
			2	1235	34.4	26.8		12.40
G*9V*C20	FC/PC60C	21	1	770	24.2	18.3	17.10	14.20
			2	1305	35.0	27.8		12.50
G*9V*D20	FC/MC/PC60D	24	1	830	24.4	19.0	17.10	14.20
			2	1225	34.8	27.0		12.80
G*9V*D20	FC/MC62D	24	1	835	25.6	19.5	17.50	14.70
			2	1235	35.8	27.4		13.00
G*9V*C16	HC42	21	1	815	25.2	18.9	17.10	14.30
			2	1240	34.8	26.4		12.40
G*9V*C20	HC42	21	1	780	25.0	18.5	17.20	14.40
			2	1200	35.0	26.6		12.70
G*9V*B12	HD48	17	1	710	24.4	17.6	16.80	14.10
			2	1150	34.0	25.4		12.10
G*9V*C16	HD48	21	1	780	24.6	18.3	17.10	14.20
			2	1195	34.8	26.4		12.60
G*9V*C20	HD48	21	1	745	24.6	18.1	16.90	14.30
			2	1330	35.8	27.6		12.70
G*9V*A12	UC36A	14	1	780	24.2	17.9	16.30	13.70
			2	1200	33.6	25.0		11.80

For Notes See Page 11.

COOLING CAPACITY - HC8B036F1 With Variable Speed Furnaces (Continued)

VARIABLE SPEED FURNACE MODEL	COIL MODEL ¹	W	COOLING					
			STAGE	RATED CFM	NET MBH		SEER	EER
					TOTAL	SENSIBLE		
1 PH 18 SEER AC WITH - VARIABLE SPEED²								
G*9V*B12	UC36B	17	1	800	24.4	18.2	16.50	13.90
			2	1165	33.8	25.2		12.20
G*9V*C16	UC36C	21	1	915	25.0	19.3	16.80	14.00
			2	1185	34.0	25.4		12.40
G*9V*C20	UC36C	21	1	760	24.2	17.8	16.80	14.10
			2	1285	34.4	26.4		12.20
G*9V*B12	UC42B	17	1	800	24.4	18.2	16.60	13.90
			2	1195	34.0	25.4		11.90
G*9V*C16	UC42C	21	1	780	24.4	18.1	17.00	14.10
			2	1205	34.2	25.4		12.50
G*9V*C20	UC42C	21	1	770	24.4	18.0	17.00	14.10
			2	1300	34.8	26.6		12.40
G*9V*C16	UC48C	21	1	780	25.0	18.8	17.40	14.40
			2	1195	34.8	26.8		12.70
G*9V*C20	UC48C	21	1	755	24.8	18.4	17.20	14.30
			2	1330	35.6	28.0		12.50
G*9V*C16	UC60C	21	1	810	25.2	18.8	17.40	14.60
			2	1235	34.8	26.2		12.50
G*9V*C20	UC60C	21	1	770	24.8	18.3	17.20	14.30
			2	1325	35.4	27.6		12.60
G*9V*D20	UC60D	24	1	830	25.2	18.8	17.40	14.60
			2	1225	35.0	26.4		12.80

1. MC coils available with a factory installed horizontal drain pan. See price pages for specific model number.

2. Variable speed furnaces have B.O.D (Blower on Delay) standard.

COOLING CAPACITY - HC8B048F1 With Variable Speed Furnaces

VARIABLE SPEED FURNACE MODEL	COIL MODEL ¹	W	COOLING					
			STAGE	RATED CFM	NET MBH		SEER	EER
					TOTAL	SENSIBLE		
1 PH 18 SEER AC WITH - VARIABLE SPEED²								
(F,L)C8V*C16	FC/MC/PC48C	21	1	880	33.0	23.4	16.30	13.30
			2	1500	46.0	34.6		11.70
(F,L)C8V*C20	FC/MC/PC48C	21	1	1030	33.0	25.0	16.40	13.40
			2	1610	46.5	35.4		11.80
FC9(C,V)*C16	FC/MC/PC48C	21	1	1090	34.0	26.0	16.90	13.86
			2	1600	46.0	35.2		11.60
FC9(C,V)*C20	FC/MC/PC48C	21	1	1010	33.0	24.6	16.20	13.20
			2	1580	46.0	35.2		11.70
FC9(C,V)*D20	FC/MC/PC48D	24	1	985	33.2	24.4	16.30	13.35
			2	1560	46.0	35.2		11.85
(F,L)C8V*C16	FC/PC60C	21	1	880	32.2	23.6	16.30	13.30
			2	1500	46.0	35.0		11.80
(F,L)C8V*C20	FC/PC60C	21	1	1030	33.2	25.3	16.40	13.40
			2	1610	46.5	36.2		11.90
FC9(C,V)*C16	FC/PC60C	21	1	1090	33.6	26.0	16.80	13.75
			2	1600	46.5	35.8		11.70
FC9(C,V)*C20	FC/PC60C	21	1	1010	33.0	25.0	16.30	13.30
			2	1580	46.5	35.8		11.90
FC9(C,V)*D20	FC/MC/PC60D	24	1	985	33.0	24.5	16.30	13.30
			2	1560	46.5	35.8		12.00
(F,L)C8V*C20	FC/MC62D	21	1	1030	33.6	25.4	16.70	13.60
			2	1610	46.5	36.0		11.85
FC9(C,V)*C20	FC/MC62D	21	1	1010	33.2	25.2	16.40	13.35
			2	1580	46.0	36.0		11.80

For Notes See Page 13.

COOLING CAPACITY - HC8B048F1 With Variable Speed Furnaces (Continued)

VARIABLE SPEED FURNACE MODEL	COIL MODEL ¹	W	COOLING					
			STAGE	RATED CFM	NET MBH		SEER	EER
					TOTAL	SENSIBLE		
1 PH 18 SEER AC WITH - VARIABLE SPEED²								
FC9(C,V)*D20	FC/MC62D	24	1	985	33.0	24.8	16.40	13.35
			2	1560	47.0	35.8		12.06
C*(8,L)C*C16	FC/MC/PC48C	21	1	1035	33.6	25.0	16.60	13.60
			2	1615	46.5	35.6		11.80
C*(8,L)C*C20	FC/MC/PC48C	21	1	1080	33.6	25.6	16.30	13.50
			2	1640	46.5	35.6		11.80
C*9C*C16	FC/MC/PC48C	21	1	1050	33.4	25.2	16.40	13.40
			2	1590	46.0	35.2		11.70
C*9C*C20	FC/MC/PC48C	21	1	1055	33.6	25.2	16.50	13.50
			2	1655	46.0	35.2		11.70
C*9C*D20	FC/MC/PC48D	24	1	1060	33.6	25.2	16.40	13.40
			2	1645	46.5	35.6		11.70
C*(8,L)C*C16	FC/PC60C	21	1	1035	33.4	25.2	16.60	13.50
			2	1625	47.0	36.2		12.00
C*(8,L)C*C20	FC/PC60C	21	1	1015	33.2	25.0	16.80	13.70
			2	1605	47.0	36.2		12.30
C*9C*C16	FC/PC60C	21	1	1050	33.2	25.2	16.30	13.30
			2	1590	46.5	36.0		11.80
C*9C*C20	FC/PC60C	21	1	1055	33.4	25.4	16.40	13.40
			2	1655	46.5	36.0		11.80
C*9C*D20	FC/MC/PC60D	24	1	1070	33.4	25.6	16.40	13.40
			2	1615	46.5	35.8		11.80
C*9C*D20	FC/MC62D	24	1	1085	33.6	25.6	16.40	13.40
			2	1630	46.5	36.2		11.90
C*9C*D20	HC60	24	1	1070	33.2	25.4	16.40	13.30
			2	1615	46.5	35.8		11.90
C*(8,L)C*C16	HD48	21	1	1035	33.2	24.4	16.20	13.40
			2	1615	46.0	35.0		11.70
C*(8,L)C*C20	HD48	21	1	1080	32.4	24.6	16.20	13.00
			2	1640	46.0	35.0		11.70
C*9C*C16	HD48	21	1	1050	33.0	24.4	16.10	13.20
			2	1590	45.5	34.6		11.60
C*9C*C20	HD48	21	1	1055	33.2	24.6	16.20	13.40
			2	1655	45.5	34.6		11.60
C*9C*D20	HD48	24	1	1060	32.2	24.4	16.10	13.00
			2	1645	45.5	34.8		11.60
C*(8,L)C*C16	HD60	21	1	1035	33.4	24.8	16.60	13.60
			2	1625	46.0	36.0		11.80
C*(8,L)C*C20	HD60	21	1	1015	33.4	24.8	16.70	13.70
			2	1605	46.5	36.0		12.10
C*9C*C16	HD60	21	1	1050	33.6	25.0	16.30	13.40
			2	1590	46.0	35.8		11.70
C*9C*C20	HD60	21	1	1055	33.6	25.0	16.40	13.50
			2	1655	46.0	35.8		11.70
C*9C*D20	HD60	24	1	1070	33.6	25.2	16.40	13.40
			2	1615	46.0	35.8		11.80
C*(8,L)C*C16	UC48C	21	1	1035	33.0	25.0	16.40	13.40
			2	1615	46.5	35.6		11.80
C*(8,L)C*C20	UC48C	21	1	1080	33.6	25.6	16.30	13.50
			2	1640	46.5	35.6		11.80
C*9C*C16	UC48C	21	1	1050	33.6	25.2	16.30	13.40
			2	1590	46.5	35.4		11.70
C*9C*C20	UC48C	21	1	1055	33.2	25.2	16.40	13.30
			2	1655	46.5	35.4		11.70

For Notes See Page 13.

COOLING CAPACITY - HC8B048F1 With Variable Speed Furnaces (Continued)

VARIABLE SPEED FURNACE MODEL	COIL MODEL ¹	W	COOLING					
			STAGE	RATED CFM	NET MBH		SEER	EER
					TOTAL	SENSIBLE		
1 PH 18 SEER AC WITH - VARIABLE SPEED²								
C*9C*D20	UC48D	24	1	1060	33.0	25.2	16.30	13.30
			2	1645	46.5	35.4		11.70
C*(8,L)C*C16	UC60C	21	1	1035	33.2	24.6	16.40	13.50
			2	1625	46.0	35.2		11.90
C*(8,L)C*C20	UC60C	21	1	1015	33.2	24.4	16.60	13.60
			2	1605	46.5	35.4		12.10
C*9C*C16	UC60C	21	1	1050	33.0	24.6	16.10	13.20
			2	1590	46.0	35.2		11.70
C*9C*C20	UC60C	21	1	1055	33.2	24.8	16.20	13.30
			2	1655	46.0	35.2		11.70
C*9C*D20	UC60D	24	1	1070	33.2	24.8	16.30	13.30
			2	1615	46.0	35.2		11.80
G*9V*C16	FC/MC/PC48C	21	1	1050	33.4	25.2	16.40	13.40
			2	1590	46.0	35.2		11.70
G*9V*C20	FC/MC/PC48C	21	1	1055	33.6	25.2	16.50	13.50
			2	1655	46.0	35.2		11.70
G*9V*D20	FC/MC/PC48D	24	1	1060	33.6	25.2	16.40	13.40
			2	1645	46.5	35.6		11.70
G*9V*C16	FC/PC60C	21	1	1050	33.2	25.2	16.30	13.30
			2	1590	46.5	36.0		11.80
G*9V*C20	FC/PC60C	21	1	1055	33.4	25.4	16.40	13.40
			2	1655	46.5	36.0		11.80
G*9V*D20	FC/MC/PC60D	24	1	1070	33.4	25.6	16.40	13.40
			2	1615	46.5	35.8		11.80
G*9V*D20	FC/MC62D	24	1	1085	33.6	25.6	16.40	13.40
			2	1630	46.5	36.2		11.90
G*9V*D20	HC60	24	1	1070	33.2	25.4	16.40	13.30
			2	1615	46.5	35.8		11.90
G*9V*C16	HD48	21	1	1050	33.0	24.4	16.10	13.20
			2	1590	45.5	34.6		11.60
G*9V*C20	HD48	21	1	1055	33.2	24.6	16.20	13.40
			2	1655	45.5	34.6		11.60
G*9V*D20	HD48	24	1	1060	32.2	24.4	16.10	13.00
			2	1645	45.5	34.8		11.60
G*9V*C16	HD60	21	1	1050	33.6	25.0	16.30	13.40
			2	1590	46.0	35.8		11.70
G*9V*C20	HD60	21	1	1055	33.6	25.0	16.40	13.50
			2	1655	46.0	35.8		11.70
G*9V*D20	HD60	24	1	1070	33.6	25.2	16.40	13.40
			2	1615	46.0	35.8		11.80
G*9V*C16	UC48C	21	1	1050	33.6	25.2	16.30	13.40
			2	1590	46.5	35.4		11.70
G*9V*C20	UC48C	21	1	1055	33.2	25.2	16.40	13.30
			2	1655	46.5	35.4		11.70
G*9V*D20	UC48D	24	1	1060	33.0	25.2	16.30	13.30
			2	1645	46.5	35.4		11.70
G*9V*C16	UC60C	21	1	1050	33.0	24.6	16.10	13.20
			2	1590	46.0	35.2		11.70
G*9V*C20	UC60C	21	1	1055	33.2	24.8	16.20	13.30
			2	1655	46.0	35.2		11.70
G*9V*D20	UC60D	24	1	1070	33.2	24.8	16.30	13.30
			2	1615	46.0	35.2		11.80

1. MC coils available with a factory installed horizontal drain pan. See price pages for specific model number.

2. Variable speed furnaces have B.O.D (Blower on Delay) standard.

COOLING CAPACITY - HC8B060F1 With Variable Speed Furnaces

VARIABLE SPEED FURNACE MODEL	COIL MODEL ¹	W	COOLING					
			STAGE	RATED CFM	NET MBH		SEER	EER
					TOTAL	SENSIBLE		
1 PH 18 SEER AC WITH - VARIABLE SPEED²								
(F,L)C8V*C20	FC/PC60C	21	1	1120	40.0	28.6	15.00	12.35
			2	1730	56.0	41.0		11.25
FC9(C,V)*C20	FC/PC60C	21	1	1075	39.5	28.0	14.70	12.15
			2	1650	55.0	40.0		11.20
FC9(C,V)*D20	FC/MC/PC60D	24	1	1020	39.0	27.4	14.70	12.15
			2	1620	55.0	40.0		11.35
(F,L)C8V*C20	FC/MC62D	21	1	1120	40.0	29.0	15.00	12.40
			2	1730	56.0	41.5		11.25
FC9(C,V)*C20	FC/MC62D	21	1	1075	40.0	28.4	14.80	12.25
			2	1650	55.5	40.5		11.25
FC9(C,V)*D20	FC/MC62D	24	1	1020	39.5	27.6	14.80	12.20
			2	1620	55.5	40.0		11.40
C*(8,L)C*C20	FC/PC60C	21	1	1015	40.0	27.8	15.30	12.60
			2	1605	55.5	40.0		11.60
C*9C*C20	FC/PC60C	21	1	1055	40.0	28.2	15.20	12.50
			2	1655	55.0	40.0		11.30
C*(8,L)C*C20	FC/MC/PC60D	21	1	1015	40.0	27.8	15.30	12.50
			2	1605	55.5	40.0		11.60
C*9C*C20	FC/MC/PC60D	21	1	1055	40.0	27.8	15.30	12.50
			2	1655	55.0	40.0		11.30
C*9C*D20	FC/MC/PC60D	24	1	1070	40.5	28.4	15.20	12.50
			2	1615	55.0	40.0		11.40
C*(8,L)C*C20	FC/MC62D	21	1	1015	39.5	28.0	15.20	12.50
			2	1615	56.0	40.5		11.70
C*9C*C20	FC/MC62D	21	1	1040	39.5	28.0	15.20	12.50
			2	1655	55.5	40.5		11.40
C*9C*D20	FC/MC62D	24	1	1085	40.5	28.6	15.20	12.50
			2	1630	55.5	40.5		11.50
C*9C*D20	HC60	24	1	1070	40.0	28.2	15.20	12.40
			2	1615	55.5	40.0		11.40
C*(8,L)C*C20	HD60	21	1	1015	39.5	27.6	15.10	12.40
			2	1605	55.5	40.0		11.60
C*9C*C20	HD60	21	1	1055	39.0	27.8	15.10	12.20
			2	1655	55.0	40.0		11.20
C*9C*D20	HD60	24	1	1070	40.0	28.2	15.10	12.40
			2	1615	55.0	40.0		11.40
C*(8,L)C*C20	UC60C	21	1	1015	39.5	27.2	15.00	12.30
			2	1605	55.0	39.5		11.50
C*9C*C20	UC60C	21	1	1055	39.5	27.6	15.00	12.20
			2	1655	54.5	39.0		11.20
C*9C*D20	UC60D	24	1	1070	39.5	27.8	14.90	12.20
			2	1615	54.5	39.0		11.30
G*9V*C20	FC/PC60C	21	1	1055	40.0	28.2	15.20	12.50
			2	1655	55.0	40.0		11.30
G*9V*C20	FC/MC/PC60D	21	1	1055	40.0	27.8	15.30	12.50
			2	1655	55.0	40.0		11.30
G*9V*D20	FC/MC/PC60D	24	1	1070	40.5	28.4	15.20	12.50
			2	1615	55.0	40.0		11.40
G*9V*C20	FC/MC62D	21	1	1040	39.5	28.0	15.20	12.50
			2	1655	55.5	40.5		11.40

For Notes See Page 15.

COOLING CAPACITY - HC8B060F1 With Variable Speed Furnaces (Continued)

VARIABLE SPEED FURNACE MODEL	COIL MODEL ¹	W	COOLING					
			STAGE	RATED CFM	NET MBH		SEER	EER
					TOTAL	SENSIBLE		
1 PH 18 SEER AC WITH - VARIABLE SPEED²								
G*9V*D20	FC/MC62D	24	1	1085	40.5	28.6	15.20	12.50
			2	1630	55.5	40.5		11.50
G*9V*D20	HC60	24	1	1070	40.0	28.2	15.20	12.40
			2	1615	55.5	40.0		11.40
G*9V*C20	HD60	21	1	1055	39.0	27.8	15.10	12.20
			2	1655	55.0	40.0		11.20
G*9V*D20	HD60	24	1	1070	40.0	28.2	15.10	12.40
			2	1615	55.0	40.0		11.40
G*9V*C20	UC60C	21	1	1055	39.5	27.6	15.00	12.20
			2	1655	54.5	39.0		11.20
G*9V*D20	UC60D	24	1	1070	39.5	27.8	14.90	12.20
			2	1615	54.5	39.0		11.30

1. MC coils available with a factory installed horizontal drain pan. See price pages for specific model number.
2. Variable speed furnaces have B.O.D (Blower on Delay) standard.

HEATING CAPACITY - With Air Handler

UNIT MODEL	AIR HANDLER MODEL	COIL ¹ MODEL	W	HEATING					
				STAGE	RATED CFM	NET MBH		HSPF	COP @ 47°
						47° OD	17° OD		
18 SEER HP WITH MV - VARIABLE SPEED									
HC8B024F1	MV12B	FC/MC43B	17	1	645	19.3	—	—	4.00
				2	835	24.0	17.0	9.60	4.00
				2	645	24.0	15.2	9.30	3.40
	MV12D	FC/MC48D	24	1	645	19.3	—	—	4.00
				2	835	24.0	16.8	9.80	4.00
				2	645	24.0	15.0	9.50	3.40
	MV12D	FC/MC60D	24	1	645	19.3	—	—	4.00
				2	835	24.0	16.8	9.80	4.00
				2	645	24.0	15.0	9.50	3.40
HC8B036F1	MV16C	FC/MC43C	21	1	775	26.4	—	—	4.20
				2	1200	36.0	25.8	10.00	4.40
				2	775	36.0	24.0	9.70	3.40
	MV16C	FC/MC48C	21	1	775	26.4	—	—	4.20
				2	1200	36.0	25.8	10.00	4.40
				2	775	36.0	24.0	9.70	3.40
	MV12D	FC/MC48D	24	1	845	26.4	—	—	4.20
				2	1245	36.0	25.8	10.00	4.40
				2	845	36.0	24.0	9.70	3.40
	MV12D	FC/MC60D	24	1	845	26.4	—	—	4.20
				2	1245	36.0	25.8	10.00	4.40
				2	845	36.0	24.0	9.70	3.40
	MV12D	FC/MC62D	24	1	845	26.4	—	—	4.20
				2	1245	36.0	25.8	10.00	4.40
				2	845	36.0	24.0	9.70	3.40
HC8B048F1	MV16C	FC/MC48C	21	1	1000	35.6	—	—	3.60
				2	1600	48.0	32.6	9.30	3.80
				2	1000	38.0	25.4	9.00	3.00
	MV20D	FC/MC48D	24	1	1045	36.0	—	—	3.60
				2	1570	48.0	32.6	9.30	3.80
				2	1045	38.0	25.6	9.00	3.00
	MV20D	FC/MC60D	24	1	1045	36.0	—	—	3.80
				2	1570	48.0	32.4	9.80	4.00
				2	1045	38.5	25.8	9.50	3.20
MV20D	FC/MC62D	24	1	1045	35.8	—	—	3.80	
			2	1570	48.0	32.0	9.80	4.00	
			2	1045	38.0	25.0	9.50	3.20	
HC8B060F1	MV20D	FC/MC60D	24	1	1175	43.0	—	—	3.40
				2	1820	58.0	39.5	9.30	3.80
				2	1175	46.5	27.4	9.00	3.00
	MV20D	FC/MC62D	24	1	1175	43.0	—	—	3.40
				2	1820	58.0	39.0	9.30	3.80
				2	1175	46.0	27.0	9.00	3.00
18 SEER HP WITH AV/SV - VARIABLE SPEED									
HC8B024F1	AV36	-	21	1	600	19.2	—	—	3.80
				2	765	24.0	16.9	9.60	4.00
				2	600	24.0	15.1	9.30	3.20
HC8B036F1	AV36	-	21	1	830	26.5	—	—	4.20
				2	1270	36.0	26.6	9.60	4.20
				2	830	36.0	24.4	9.30	4.20
	AV/SV48	-	24	1	910	27.0	—	—	4.60
				2	1190	36.0	26.2	10.00	4.60
				2	910	36.0	24.4	9.70	3.60
HC8B048F1	AV/SV48	-	24	1	1135	36.2	—	—	4.00
				2	1610	48.0	32.4	9.80	4.00
				2	1135	38.5	25.6	9.50	3.40
	AV/SV60	-	24	1	1085	36.0	—	—	4.00
				2	1655	48.0	32.6	9.80	4.00
				2	1085	39.0	25.8	9.50	3.40
HC8B060F1	AV/SV60	-	24	1	1145	43.0	—	—	3.60
				2	1765	58.0	39.4	9.30	3.80
				2	1145	46.5	27.2	9.00	3.00

Rated in accordance with DOE test procedures (Federal Register 12-27-79 and 3-18-88) and ARI Standards 210.

Cooling MBH based on 80°F entering air temperature, 50% RH, and rated air flow.

EER (Energy Efficiency Ratio) is the total cooling output in BTU's at 95°F outdoor ambient divided by the total electric power in watt-hours at those conditions.

SEER (Seasonal Energy Efficiency Ratio) is the total cooling output in BTU's during a normal annual usage period for cooling divided by the total electric power input in watt-hours during the same period.

1. MC coils available with a factory installed horizontal drain pan. See price pages for specific model number.

** Refer to Quick Selection Chart for specific furnace match-up.

HEATING CAPACITY - HC8B024F1 With Variable Speed Furnaces

VARIABLE SPEED FURNACE MODEL	COIL MODEL ¹	W	ARI HEATING ²					
			STAGE	RATED CFM	NET MBH		HSPF	COP @ 47
					47 OD	17 OD		
18 SEER HP WITH VARIABLE SPEED FURNACES³								
FC9(C,V)*B12	FC/MC/PC43B	17	1	560	19.1	–	–	3.80
			2	820	24.2	17.1	9.60	3.90
			2	560	23.8	15.0	9.30	3.20
C*(8,L)C*A12	FC/MC/PC30A	14	1	590	18.9	–	–	3.76
			2	805	24.0	10.1	9.40	3.76
			2	590	23.6	9.4	9.20	3.17
C*(8,L)C*B12	FC/MC/PC30B	17	1	565	18.9	–	–	3.80
			2	815	23.8	10.1	9.60	3.80
			2	565	23.5	9.4	9.40	3.20
C*9C*B12	FC/MC/PC30B	17	1	565	18.9	–	–	3.76
			2	790	24.0	10.2	9.40	3.76
			2	565	23.6	9.4	9.30	3.18
C*(8,L)C*A12	FC/MC/PC32A	14	1	550	18.9	–	–	3.64
			2	775	24.0	9.9	9.30	3.70
			2	550	23.5	9.3	9.10	3.07
C*(8,L)C*B12	FC/MC/PC35B	17	1	515	18.4	–	–	3.60
			2	760	23.8	10.1	9.50	3.72
			2	515	23.3	9.3	9.30	2.99
C*9C*B12	FC/MC/PC35B	17	1	550	18.4	–	–	3.66
			2	815	24.0	9.9	9.30	3.78
			2	550	23.5	9.4	9.20	3.08
C*(8,L)C*A12	FC/MC/PC36A	14	1	595	18.5	–	–	3.82
			2	805	24.0	10.2	9.50	3.82
			2	595	23.7	9.4	9.30	3.24
C*(8,L)C*B12	FC/MC/PC36B	17	1	525	18.5	–	–	3.70
			2	765	23.8	9.8	9.60	3.80
			2	525	23.4	9.3	9.40	3.09
C*9C*B12	FC/MC/PC36B	17	1	590	18.5	–	–	3.82
			2	815	24.0	10.2	9.50	3.82
			2	590	23.7	9.4	9.30	3.24
C*(8,L)C*A12	FC/MC/PC37A	14	1	585	19.2	–	–	3.82
			2	805	24.2	10.2	9.30	3.84
			2	585	23.7	9.4	9.20	3.22
C*(8,L)C*B12	FC/MC/PC43B	17	1	515	18.8	–	–	3.68
			2	760	24.0	9.8	9.60	3.84
			2	515	23.4	9.3	9.40	3.07
C*9C*B12	FC/MC/PC43B	17	1	550	19.0	–	–	3.76
			2	800	24.0	10.1	9.50	3.86
			2	550	23.5	9.4	9.30	3.16
C*(8,L)C*A12	HC30	14	1	550	18.5	–	–	3.58
			2	775	23.8	9.8	9.20	3.64
			2	550	23.4	9.6	9.00	3.02
C*(8,L)C*A12	HD36	14	1	595	17.2	–	–	2.98
			2	805	23.2	9.7	9.10	3.10
			2	595	22.6	8.9	8.70	2.43
C*(8,L)C*B12	HD36	17	1	515	16.9	–	–	2.72
			2	760	23.0	10.7	9.10	3.02
			2	515	22.1	9.1	8.60	2.21
C*9C*B12	HD36	17	1	590	17.2	–	–	2.98
			2	815	23.2	9.7	9.10	3.12
			2	590	22.6	8.6	8.70	2.43

For Notes See Page 19.

HEATING CAPACITY - HC8B024F1 With Variable Speed Furnaces (Continued)

VARIABLE SPEED FURNACE MODEL	COIL MODEL ¹	W	ARI HEATING ²					
			STAGE	RATED CFM	NET MBH		HSPF	COP @ 47
					47 OD	17 OD		
18 SEER HP WITH VARIABLE SPEED FURNACES³								
C*(8,L)C*A12	UC30A	14	1	590	19.0	—	—	3.80
			2	805	24.0	9.9	9.40	3.80
			2	590	23.6	9.4	9.20	3.20
C*(8,L)C*B12	UC30B	17	1	565	18.9	—	—	3.82
			2	815	23.8	9.9	9.60	3.82
			2	565	23.6	9.4	9.50	3.23
C*9C*B12	UC30B	17	1	565	18.9	—	—	3.80
			2	790	24.0	9.9	9.40	3.80
			2	565	23.6	9.4	9.30	3.21
C*(8,L)C*A12	UC36A	14	1	595	19.0	—	—	3.80
			2	805	24.0	9.9	9.40	3.80
			2	595	23.6	9.4	9.30	3.21
C*(8,L)C*B12	UC36B	17	1	525	17.3	—	—	3.16
			2	765	23.8	10.0	9.60	3.70
			2	525	23.8	8.8	8.70	3.03
C*9C*B12	UC36B	17	1	590	19.0	—	—	3.80
			2	815	24.0	9.9	9.50	3.80
			2	590	23.6	9.4	9.30	3.21
G*9V*A12	FC/MC/PC30A	14	1	625	18.9	—	—	3.70
			2	800	24.0	9.9	9.20	3.70
			2	625	23.8	9.5	8.90	3.21
G*9V*B12	FC/MC/PC30B	17	1	565	18.9	—	—	3.76
			2	790	24.0	10.2	9.40	3.76
			2	565	23.6	9.4	9.30	3.18
G*9V*A12	FC/MC/PC32A	14	1	625	19.2	—	—	3.68
			2	800	24.2	10.0	9.00	3.68
			2	625	23.8	9.5	8.90	3.20
G*9V*B12	FC/MC/PC35B	17	1	550	18.4	—	—	3.66
			2	815	24.0	9.9	9.30	3.78
			2	550	23.5	9.4	9.20	3.08
G*9V*A12	FC/MC/PC36A	14	1	625	19.5	—	—	3.76
			2	800	24.0	9.9	9.20	3.76
			2	625	23.8	9.5	8.90	3.26
G*9V*B12	FC/MC/PC36B	17	1	590	18.5	—	—	3.82
			2	815	24.0	10.2	9.50	3.82
			2	590	23.7	9.4	9.30	3.24
G*9V*A12	FC/MC/PC37A	14	1	535	18.8	—	—	3.68
			2	800	24.2	10.2	9.20	3.82
			2	535	23.6	9.3	9.00	3.09
G*9V*B12	FC/MC/PC43B	17	1	550	19.0	—	—	3.76
			2	800	24.0	10.1	9.50	3.86
			2	550	23.5	9.4	9.30	3.16
G*9V*A12	HC30	14	1	625	18.6	—	—	3.64
			2	800	24.0	9.9	9.20	3.64
			2	625	23.7	9.5	8.90	3.14
G*9V*A12	HD36	14	1	625	17.4	—	—	3.02
			2	800	23.2	9.2	8.90	3.04
			2	625	22.8	8.7	8.40	2.47
G*9V*B12	HD36	17	1	590	17.2	—	—	2.98
			2	815	23.2	9.7	9.10	3.12
			2	590	22.6	8.6	8.70	2.43

For Notes See Page 19.

HEATING CAPACITY - HC8B024F1 With Variable Speed Furnaces (Continued)

VARIABLE SPEED FURNACE MODEL	COIL MODEL ¹	W	ARI HEATING ²					
			STAGE	RATED CFM	NET MBH		HSPF	COP @ 47
					47 OD	17 OD		
18 SEER HP WITH VARIABLE SPEED FURNACES³								
G*9V*A12	UC30A	14	1	625	19.3	—	—	3.74
			2	800	24.0	10.0	9.20	3.74
			2	625	23.8	9.5	8.90	3.24
G*9V*B12	UC30B	17	1	565	18.9	—	—	3.80
			2	790	24.0	9.9	9.40	3.80
			2	565	23.6	9.4	9.30	3.21
G*9V*A12	UC36A	14	1	625	17.2	—	—	3.22
			2	800	24.0	10.1	9.20	3.68
			2	625	24.2	9.3	9.10	3.18
G*9V*B12	UC36B	17	1	590	19.0	—	—	3.80
			2	815	24.0	9.9	9.50	3.80
			2	590	23.6	9.4	9.30	3.21

1. MC coils available with a factory installed horizontal drain pan. See price pages for specific model number.

2. Heating MBH based on ARI standards of 70° DB entering indoor air, 72% RH outdoor air with 25 feet of interconnecting piping and no supplemental electric heat operation.

3. Variable speed furnaces have B.O.D (Blower on Delay) standard.

CP equals MBH output divided by (total KW input x 3.412).

HSPF (Heating Seasonal Performance Factor) is the total heating output during a normal annual usage period for heating divided by the total electric power input during the same period.

— = Not Applicable.

HEATING CAPACITY - HC8B036F1 With Variable Speed Furnaces

VARIABLE SPEED FURNACE MODEL	COIL MODEL ¹	W	ARI HEATING ²					
			STAGE	RATED CFM	NET MBH		HSPF	COP @ 47
					47 OD	17 OD		
18 SEER HP WITH VARIABLE SPEED FURNACES³								
(F,L)C8V*B16	FC/MC/PC43B	17	1	750	26.4	—	—	4.00
			2	1200	36.0	26.6	9.35	4.20
			2	750	36.0	24.6	9.00	3.20
(F,L)C8V*C16	FC/MC/PC43C	21	1	640	26.0	—	—	3.80
			2	1200	36.0	26.4	9.35	4.20
			2	640	36.0	24.4	9.00	3.00
(F,L)C8V*C20	FC/MC/PC43C	21	1	780	26.4	—	—	4.00
			2	1200	36.0	26.4	9.55	4.20
			2	780	36.0	24.4	9.20	3.20
FC9(C,V)*B12	FC/MC/PC43B	17	1	770	26.4	—	—	4.00
			2	1185	36.0	26.8	9.55	4.20
			2	770	36.0	24.6	9.20	3.20
FC9(C,V)*C16	FC/MC/PC43C	21	1	770	26.4	—	—	4.00
			2	1175	36.0	26.4	9.55	4.20
			2	770	36.0	24.4	9.20	3.20
FC9(C,V)*C20	FC/MC/PC43C	21	1	790	26.6	—	—	4.00
			2	1195	36.0	26.6	9.55	4.20
			2	790	36.0	24.4	9.20	3.20
(F,L)C8V*C16	FC/MC/PC48C	21	1	640	26.0	—	—	3.80
			2	1200	36.0	26.4	9.55	4.20
			2	640	36.0	24.4	9.20	3.00
(F,L)C8V*C20	FC/MC/PC48C	21	1	780	26.4	—	—	4.00
			2	1200	36.0	26.4	9.55	4.20
			2	780	36.0	24.4	9.20	3.20
FC9(C,V)*C16	FC/MC/PC48C	21	1	770	26.4	—	—	4.00
			2	1175	36.0	26.4	9.55	4.20
			2	770	36.0	24.4	9.20	3.20
FC9(C,V)*C20	FC/MC/PC48C	21	1	790	26.4	—	—	4.00
			2	1195	36.0	26.4	9.55	4.20
			2	790	36.0	24.4	9.20	3.20

For Notes See Page 26.

HEATING CAPACITY - HC8B036F1 With Variable Speed Furnaces (Continued)

VARIABLE SPEED FURNACE MODEL	COIL MODEL ¹	W	ARI HEATING ²					
			STAGE	RATED CFM	NET MBH		HSPF	COP @ 47
					47 OD	17 OD		
18 SEER HP WITH VARIABLE SPEED FURNACES³								
FC9(C,V)*D20	FC/MC/PC48D	24	1	775	26.4	–	–	4.00
			2	1220	36.0	26.4	9.55	4.20
			2	775	36.0	24.4	9.20	3.20
(F,L)C8V*C16	FC/PC60C	21	1	640	26.2	–	–	4.00
			2	1200	36.0	26.2	10.00	4.40
			2	640	36.0	24.4	9.70	3.20
(F,L)C8V*C20	FC/PC60C	21	1	780	26.6	–	–	4.20
			2	1200	36.0	26.2	10.00	4.40
			2	780	36.0	24.4	9.70	3.40
FC9(C,V)*C16	FC/PC60C	21	1	770	26.6	–	–	4.40
			2	1175	36.0	26.2	10.00	4.40
			2	770	36.0	24.4	9.70	3.60
FC9(C,V)*C20	FC/PC60C	21	1	790	26.8	–	–	4.40
			2	1195	36.0	26.2	10.00	4.40
			2	790	36.0	24.4	9.70	3.60
FC9(C,V)*D20	FC/MC/PC60D	24	1	775	26.6	–	–	4.40
			2	1220	36.0	26.2	10.00	4.40
			2	775	36.0	24.6	9.70	3.40
(F,L)C8V*C20	FC/MC62D	24	1	780	26.4	–	–	4.00
			2	1200	36.0	26.2	9.55	4.20
			2	780	36.0	23.8	9.35	3.20
FC9(C,V)*C20	FC/MC62D	24	1	790	26.4	–	–	4.00
			2	1195	36.0	26.0	9.55	4.20
			2	790	36.0	24.0	9.35	3.40
FC9(C,V)*D20	FC/MC62D	24	1	775	26.4	–	–	4.00
			2	1220	36.0	26.0	10.00	4.40
			2	775	36.0	23.8	9.80	3.20
(F,L)C8V*C16	HC42	21	1	640	26.0	–	–	3.80
			2	1200	36.0	26.4	9.55	4.20
			2	640	36.0	24.4	9.35	3.00
(F,L)C8V*C20	HC42	21	1	780	26.4	–	–	4.00
			2	1200	36.0	26.4	9.55	4.00
			2	780	36.0	24.4	9.35	3.20
FC9(C,V)*C16	HC42	21	1	770	26.4	–	–	4.00
			2	1175	36.0	26.4	9.55	4.20
			2	770	36.0	24.4	9.35	3.20
FC9(C,V)*C20	HC42	21	1	790	26.4	–	–	4.00
			2	1195	36.0	26.6	9.55	4.20
			2	790	36.0	24.4	9.35	3.20
C*(8,L)C*B12	FC/MC/PC35B	17	1	745	26.2	–	–	3.78
			2	1220	36.2	27.0	9.30	3.96
			2	745	35.7	24.9	9.20	3.04
C*(8,L)C*C16	FC/MC/PC35C	21	1	815	26.2	–	–	3.90
			2	1235	35.8	26.8	9.60	4.06
			2	815	35.9	25.0	9.20	3.14
C*(8,L)C*C20	FC/MC/PC35C	21	1	945	26.8	–	–	4.04
			2	1170	35.6	26.6	9.70	4.04
			2	945	36.4	25.2	8.80	3.36
C*9C*B12	FC/MC/PC35B	17	1	810	26.4	–	–	3.86
			2	1190	36.2	27.0	9.40	4.00
			2	810	36.0	25.1	8.90	3.13
C*9C*C16	FC/MC/PC35C	21	1	790	26.2	–	–	3.90
			2	1215	36.0	26.8	9.50	4.06
			2	790	35.9	25.0	9.20	3.15

For Notes See Page 26.

HEATING CAPACITY - HC8B036F1 With Variable Speed Furnaces (Continued)

VARIABLE SPEED FURNACE MODEL	COIL MODEL ¹	W	ARI HEATING ²					
			STAGE	RATED CFM	NET MBH		HSPF	COP @ 47
					47 OD	17 OD		
18 SEER HP WITH VARIABLE SPEED FURNACES³								
C*9C*C20	FC/MC/PC35C	21	1	760	26.2	–	–	3.80
			2	1295	36.4	27.2	9.40	4.06
			2	760	35.8	24.9	9.20	3.06
C*(8,L)C*A12	FC/MC/PC36A	14	1	815	26.4	–	–	3.88
			2	1190	36.2	27.0	9.30	3.92
			2	815	36.1	25.1	9.00	3.14
C*(8,L)C*B12	FC/MC/PC36B	17	1	745	26.2	–	–	3.82
			2	1220	36.0	27.0	9.50	4.00
			2	745	36.1	25.1	8.30	3.04
C*(8,L)C*C16	FC/MC/PC36C	21	1	805	26.2	–	–	3.96
			2	1235	35.8	26.6	9.60	4.04
			2	805	35.9	24.9	9.40	3.18
C*(8,L)C*C20	FC/MC/PC36C	21	1	800	26.2	–	–	3.96
			2	1240	35.8	26.6	9.70	4.06
			2	800	35.9	24.9	9.50	3.19
C*9C*B12	FC/MC/PC36B	17	1	800	26.4	–	–	3.90
			2	1165	36.0	26.8	9.50	4.00
			2	800	36.0	25.0	9.10	3.16
C*9C*C16	FC/MC/PC36C	21	1	915	26.6	–	–	4.02
			2	1185	35.8	26.6	9.70	4.04
			2	915	36.4	25.1	9.00	3.28
C*9C*C20	FC/MC/PC36C	21	1	760	26.2	–	–	3.86
			2	1285	36.2	27.0	9.50	4.08
			2	760	36.1	25.1	8.30	3.07
C*(8,L)C*A12	FC/MC/PC37A	14	1	655	26.0	–	–	3.70
			2	980	35.6	26.4	9.60	3.90
			2	655	35.2	24.6	9.20	2.95
C*(8,L)C*B12	FC/MC/PC42B	17	1	760	26.4	–	–	3.98
			2	1175	36.0	26.8	9.60	4.10
			2	760	36.2	25.1	9.60	3.19
C*(8,L)C*C16	FC/MC/PC42C	21	1	825	26.6	–	–	4.10
			2	1205	35.8	26.6	9.90	4.20
			2	825	36.4	25.1	9.60	3.29
C*(8,L)C*C20	FC/MC/PC42C	21	1	735	26.4	–	–	4.02
			2	1170	35.6	26.4	9.90	4.20
			2	735	36.2	25.0	9.70	3.21
C*9C*B12	FC/MC/PC42B	17	1	800	26.6	–	–	4.02
			2	1195	36.2	27.2	9.30	4.02
			2	800	36.5	25.2	9.20	3.26
C*9C*C16	FC/MC/PC42C	21	1	780	26.4	–	–	3.98
			2	1205	35.8	26.6	9.70	4.12
			2	780	36.2	25.1	9.50	3.19
C*9C*C20	FC/MC/PC42C	21	1	770	26.6	–	–	4.00
			2	1315	36.2	27.0	9.60	4.18
			2	770	36.3	25.2	9.50	3.20
C*(8,L)C*B12	FC/MC/PC43B	17	1	745	26.2	–	–	3.88
			2	1210	36.4	27.0	9.40	4.08
			2	745	35.5	24.7	9.20	3.12
C*(8,L)C*C16	FC/MC/PC43C	21	1	800	26.4	–	–	4.00
			2	1205	36.0	26.6	9.70	4.20
			2	800	35.7	24.9	9.30	3.23
C*(8,L)C*C20	FC/MC/PC43C	21	1	745	26.2	–	–	3.92
			2	1190	36.0	26.4	9.80	4.24
			2	745	35.5	24.7	9.40	3.15

For Notes See Page 26.

HEATING CAPACITY - HC8B036F1 With Variable Speed Furnaces (Continued)

VARIABLE SPEED FURNACE MODEL	COIL MODEL ¹	W	ARI HEATING ²					
			STAGE	RATED CFM	NET MBH		HSPF	COP @ 47
					47 OD	17 OD		
18 SEER HP WITH VARIABLE SPEED FURNACES³								
C*9C*B12	FC/MC/PC43B	17	1	815	26.6	–	–	3.96
			2	1200	36.2	27.0	9.40	4.08
			2	815	35.8	25.1	9.00	3.23
C*9C*C16	FC/MC/PC43C	21	1	815	26.4	–	–	3.98
			2	1240	36.2	26.8	9.60	4.16
			2	815	35.8	25.0	9.00	3.23
C*9C*C20	FC/MC/PC43C	21	1	780	26.2	–	–	3.90
			2	1200	36.0	26.6	9.70	4.20
			2	780	35.5	24.7	9.20	3.13
C*(8,L)C*C16	FC/MC/PC48C	21	1	810	27.2	–	–	3.80
			2	1210	36.2	26.8	9.90	4.22
			2	810	35.6	25.4	9.30	3.28
C*(8,L)C*C20	FC/MC/PC48C	21	1	720	27.0	–	–	3.68
			2	1155	36.0	26.6	10.00	4.18
			2	720	35.3	25.3	9.40	3.13
C*9C*C16	FC/MC/PC48C	21	1	780	27.2	–	–	3.78
			2	1195	36.4	27.0	9.80	4.18
			2	780	35.6	25.4	9.20	3.28
C*9C*C20	FC/MC/PC48C	21	1	745	27.0	–	–	3.72
			2	1305	36.6	27.0	9.60	4.20
			2	745	35.1	25.0	9.10	3.17
C*(8,L)C*C16	FC/PC60C	21	1	810	27.0	–	–	3.84
			2	1195	36.2	26.8	10.00	4.24
			2	810	35.5	25.0	9.30	3.32
C*(8,L)C*C20	FC/PC60C	21	1	800	27.0	–	–	3.84
			2	1215	36.2	26.8	10.00	4.24
			2	800	35.6	24.9	9.40	3.29
C*9C*C16	FC/PC60C	21	1	810	27.2	–	–	3.80
			2	1235	36.4	27.0	9.70	4.18
			2	810	35.6	25.0	9.10	3.30
C*9C*C20	FC/PC60C	21	1	770	26.8	–	–	3.80
			2	1305	36.6	26.8	9.70	4.22
			2	770	35.4	24.9	9.20	3.25
C*9C*D20	FC/MC/PC60D	24	1	830	27.0	–	–	3.86
			2	1225	36.2	26.8	9.90	4.22
			2	830	35.7	25.2	9.20	3.32
C*9C*D20	FC/MC62D	24	1	835	26.4	–	–	4.12
			2	1235	36.2	26.0	9.80	4.32
			2	835	36.1	24.1	9.40	3.35
C*(8,L)C*C16	HC42	21	1	800	26.4	–	–	4.00
			2	1205	36.0	26.6	9.80	4.20
			2	800	35.7	24.9	9.30	3.23
C*(8,L)C*C20	HC42	21	1	745	26.2	–	–	3.92
			2	1190	35.8	26.4	9.80	4.22
			2	745	35.5	24.6	9.40	3.14
C*9C*C16	HC42	21	1	815	26.4	–	–	3.96
			2	1240	36.2	26.8	9.50	4.12
			2	815	35.8	25.0	9.00	3.21
C*9C*C20	HC42	21	1	780	26.4	–	–	4.00
			2	1200	36.0	26.6	9.70	4.20
			2	780	35.7	24.9	9.30	3.23
C*(8,L)C*B12	HD48	17	1	750	25.2	–	–	3.36
			2	1210	35.6	25.8	9.40	3.76
			2	750	34.7	23.6	8.90	2.67

For Notes See Page 26.

HEATING CAPACITY - HC8B036F1 With Variable Speed Furnaces (Continued)

VARIABLE SPEED FURNACE MODEL	COIL MODEL ¹	W	ARI HEATING ²					
			STAGE	RATED CFM	NET MBH		HSPF	COP @ 47
					47 OD	17 OD		
18 SEER HP WITH VARIABLE SPEED FURNACES³								
C*(8,L)C*C16	HD48	21	1	810	25.2	–	–	3.52
			2	1210	35.4	25.6	9.60	3.84
			2	810	34.9	23.7	9.10	2.79
C*(8,L)C*C20	HD48	21	1	720	25.0	–	–	3.32
			2	1155	35.2	25.4	9.70	3.78
			2	720	34.5	23.4	9.10	2.61
C*9C*B12	HD48	17	1	710	25.0	–	–	3.26
			2	1150	35.6	25.8	9.30	3.66
			2	710	34.5	23.5	8.90	2.58
C*9C*C16	HD48	21	1	780	25.2	–	–	3.52
			2	1195	35.4	25.6	9.50	3.80
			2	780	35.0	23.7	9.00	2.79
C*9C*C20	HD48	21	1	745	25.4	–	–	3.30
			2	1330	35.8	26.0	9.40	3.88
			2	745	35.3	23.7	9.20	2.61
C*(8,L)C*A12	UC36A	14	1	815	26.4	–	–	3.80
			2	1190	36.0	26.8	9.30	3.88
			2	815	36.4	25.0	9.10	3.11
C*(8,L)C*B12	UC36B	17	1	745	26.0	–	–	3.76
			2	1220	36.0	26.6	9.40	3.94
			2	745	36.1	24.9	8.40	3.05
C*(8,L)C*C16	UC36C	21	1	805	26.2	–	–	3.88
			2	1235	35.6	26.4	9.60	3.98
			2	805	36.2	24.9	9.50	3.15
C*(8,L)C*C20	UC36C	21	1	800	26.2	–	–	3.88
			2	1240	35.6	26.4	9.70	4.00
			2	800	36.2	24.9	9.50	3.15
C*9C*B12	UC36B	17	1	800	26.2	–	–	3.82
			2	1165	35.8	26.6	9.50	3.94
			2	800	36.3	25.0	9.20	3.13
C*9C*C16	UC36C	21	1	915	26.6	–	–	3.92
			2	1185	35.6	26.6	9.60	3.98
			2	915	36.5	25.1	9.10	3.23
C*9C*C20	UC36C	21	1	760	26.2	–	–	3.78
			2	1285	36.2	27.0	9.40	4.02
			2	760	36.1	25.0	8.30	3.07
C*(8,L)C*B12	UC42B	17	1	760	23.8	–	–	3.26
			2	1175	35.8	24.8	9.60	4.00
			2	760	36.1	23.3	9.50	3.06
C*(8,L)C*C16	UC42C	21	1	825	24.4	–	–	3.48
			2	1205	35.6	25.0	9.80	4.08
			2	825	36.3	22.9	9.50	3.18
C*(8,L)C*C20	UC42C	21	1	735	23.8	–	–	3.28
			2	1170	35.4	24.6	9.80	4.08
			2	735	36.0	23.2	9.70	3.08
C*9C*B12	UC42B	17	1	800	24.4	–	–	3.42
			2	1195	36.2	25.4	9.30	3.92
			2	800	36.4	23.1	9.20	3.15
C*9C*C16	UC42C	21	1	780	24.0	–	–	3.26
			2	1205	35.6	24.8	9.70	4.02
			2	780	36.1	23.3	9.40	3.06
C*9C*C20	UC42C	21	1	770	24.0	–	–	3.28
			2	1300	36.2	26.2	9.50	4.08
			2	770	36.1	23.4	9.50	3.09

For Notes See Page 26.

HEATING CAPACITY - HC8B036F1 With Variable Speed Furnaces (Continued)

VARIABLE SPEED FURNACE MODEL	COIL MODEL ¹	W	ARI HEATING ²					
			STAGE	RATED CFM	NET MBH		HSPF	COP @ 47
					47 OD	17 OD		
18 SEER HP WITH VARIABLE SPEED FURNACES³								
C*(8,L)C*C16	UC48C	21	1	810	26.8	–	–	4.24
			2	1210	36.2	26.4	9.90	4.38
			2	810	36.5	25.0	9.60	3.42
C*(8,L)C*C20	UC48C	21	1	720	26.6	–	–	4.10
			2	1155	36.0	26.4	10.00	4.36
			2	720	36.5	25.0	9.80	3.29
C*9C*C16	UC48C	21	1	780	26.8	–	–	4.22
			2	1195	36.2	26.6	9.80	4.34
			2	780	36.6	25.0	9.60	3.42
C*9C*C20	UC48C	21	1	755	27.0	–	–	4.12
			2	1330	36.6	26.8	9.60	4.34
			2	755	36.8	25.2	8.50	3.32
C*(8,L)C*C16	UC60C	21	1	810	26.4	–	–	4.16
			2	1195	36.0	26.0	10.00	4.36
			2	810	36.4	24.7	9.60	3.40
C*(8,L)C*C20	UC60C	21	1	800	26.4	–	–	4.16
			2	1215	36.0	26.0	9.90	4.36
			2	800	36.4	24.7	9.60	3.41
C*9C*C16	UC60C	21	1	810	26.6	–	–	4.12
			2	1235	36.4	26.4	9.70	4.26
			2	810	36.4	24.8	9.40	3.39
C*9C*C20	UC60C	21	1	770	26.4	–	–	4.08
			2	1325	36.6	26.4	9.70	4.34
			2	770	36.6	24.8	8.60	3.33
C*9C*D20	UC60D	24	1	830	26.6	–	–	4.14
			2	1225	36.2	26.2	9.80	4.32
			2	830	36.4	24.8	9.50	3.39
G*9V*B12	FC/MC/PC35B	17	1	810	26.4	–	–	3.86
			2	1190	36.2	27.0	9.40	4.00
			2	810	36.0	25.1	8.90	3.13
G*9V*C16	FC/MC/PC35C	21	1	790	26.2	–	–	3.90
			2	1215	36.0	26.8	9.50	4.06
			2	790	35.9	25.0	9.20	3.15
G*9V*C20	FC/MC/PC35C	21	1	760	26.2	–	–	3.80
			2	1295	36.4	27.2	9.40	4.06
			2	760	35.8	24.9	9.20	3.06
G*9V*A12	FC/MC/PC36A	14	1	780	26.4	–	–	3.82
			2	1200	36.2	27.2	9.30	3.92
			2	780	36.3	25.3	9.10	3.08
G*9V*B12	FC/MC/PC36B	17	1	800	26.4	–	–	3.90
			2	1165	36.0	26.8	9.50	4.00
			2	800	36.0	25.0	9.10	3.16
G*9V*C16	FC/MC/PC36C	21	1	915	26.6	–	–	4.02
			2	1185	35.8	26.6	9.70	4.04
			2	915	36.4	25.1	9.00	3.28
G*9V*C20	FC/MC/PC36C	21	1	760	26.2	–	–	3.86
			2	1285	36.2	27.0	9.50	4.08
			2	760	36.1	25.1	8.30	3.07
G*9V*B12	FC/MC/PC42B	17	1	800	26.6	–	–	4.02
			2	1195	36.2	27.2	9.30	4.02
			2	800	36.5	25.2	9.20	3.26
G*9V*C16	FC/MC/PC42C	21	1	780	26.4	–	–	3.98
			2	1205	35.8	26.6	9.70	4.12
			2	780	36.2	25.1	9.50	3.19

For Notes See Page 26.

HEATING CAPACITY - HC8B036F1 With Variable Speed Furnaces (Continued)

VARIABLE SPEED FURNACE MODEL	COIL MODEL ¹	W	ARI HEATING ²					
			STAGE	RATED CFM	NET MBH		HSPF	COP @ 47
					47 OD	17 OD		
18 SEER HP WITH VARIABLE SPEED FURNACES³								
G*9V*C20	FC/MC/PC42C	21	1	770	26.6	–	–	4.00
			2	1315	36.2	27.0	9.60	4.18
			2	770	36.3	25.2	9.50	3.20
G*9V*A12	FC/MC/PC37A	14	1	800	26.6	–	–	3.90
			2	1100	36.2	27.0	9.40	3.98
			2	800	36.2	25.1	8.80	3.18
G*9V*B12	FC/MC/PC43B	17	1	815	26.6	–	–	3.96
			2	1200	36.2	27.0	9.40	4.08
			2	815	35.8	25.1	9.00	3.23
G*9V*C16	FC/MC/PC43C	21	1	815	26.4	–	–	3.98
			2	1240	36.2	26.8	9.60	4.16
			2	815	35.8	25.0	9.00	3.23
G*9V*C20	FC/MC/PC43C	21	1	780	26.2	–	–	3.90
			2	1200	36.0	26.6	9.70	4.20
			2	780	35.5	24.7	9.20	3.13
G*9V*C16	FC/MC/PC48C	21	1	780	27.2	–	–	3.78
			2	1195	36.4	27.0	9.80	4.18
			2	780	35.6	25.4	9.20	3.28
G*9V*C20	FC/MC/PC48C	21	1	745	27.0	–	–	3.72
			2	1305	36.6	27.0	9.60	4.20
			2	745	35.1	25.0	9.10	3.17
G*9V*C16	FC/PC60C	21	1	810	27.2	–	–	3.80
			2	1235	36.4	27.0	9.70	4.18
			2	810	35.6	25.0	9.10	3.30
G*9V*C20	FC/PC60C	21	1	770	26.8	–	–	3.80
			2	1305	36.6	26.8	9.70	4.22
			2	770	35.4	24.9	9.20	3.25
G*9V*D20	FC/MC/PC60D	24	1	830	27.0	–	–	3.86
			2	1225	36.2	26.8	9.90	4.22
			2	830	35.7	25.2	9.20	3.32
G*9V*D20	FC/MC62D	24	1	835	26.4	–	–	4.12
			2	1235	36.2	26.0	9.80	4.32
			2	835	36.1	24.1	9.40	3.35
G*9V*C16	HC42	21	1	815	26.4	–	–	3.96
			2	1240	36.2	26.8	9.50	4.12
			2	815	35.8	25.0	9.00	3.21
G*9V*C20	HC42	21	1	780	26.4	–	–	4.00
			2	1200	36.0	26.6	9.70	4.20
			2	780	35.7	24.9	9.30	3.23
G*9V*B12	HD48	17	1	710	25.0	–	–	3.26
			2	1150	35.6	25.8	9.30	3.66
			2	710	34.5	23.5	8.90	2.58
G*9V*C16	HD48	21	1	780	25.2	–	–	3.52
			2	1195	35.4	25.6	9.50	3.80
			2	780	35.0	23.7	9.00	2.79
G*9V*C20	HD48	21	1	745	25.4	–	–	3.30
			2	1330	35.8	26.0	9.40	3.88
			2	745	35.3	23.7	9.20	2.61
G*9V*A12	UC36A	14	1	780	26.2	–	–	3.74
			2	1200	36.0	27.0	9.20	3.86
			2	780	36.3	25.0	9.00	3.07
G*9V*B12	UC36B	17	1	800	26.2	–	–	3.82
			2	1165	35.8	26.6	9.50	3.94
			2	800	36.3	25.0	9.20	3.13

For Notes See Page 26.

HEATING CAPACITY - HC8B036F1 With Variable Speed Furnaces (Continued)

VARIABLE SPEED FURNACE MODEL	COIL MODEL ¹	W	ARI HEATING ²					
			STAGE	RATED CFM	NET MBH		HSPF	COP @ 47
					47 OD	17 OD		
18 SEER HP WITH VARIABLE SPEED FURNACES³								
G*9V*C16	UC36C	21	1	915	26.6	—	—	3.92
			2	1185	35.6	26.6	9.60	3.98
			2	915	36.5	25.1	9.10	3.23
G*9V*C20	UC36C	21	1	760	26.2	—	—	3.78
			2	1285	36.2	27.0	9.40	4.02
			2	760	36.1	25.0	8.30	3.07
G*9V*B12	UC42B	17	1	800	24.4	—	—	3.42
			2	1195	36.2	25.4	9.30	3.92
			2	800	36.4	23.1	9.20	3.15
G*9V*C16	UC42C	21	1	780	24.0	—	—	3.26
			2	1205	35.6	24.8	9.70	4.02
			2	780	36.1	23.3	9.40	3.06
G*9V*C20	UC42C	21	1	770	24.0	—	—	3.28
			2	1300	36.2	26.2	9.50	4.08
			2	770	36.1	23.4	9.50	3.09
G*9V*C16	UC48C	21	1	780	26.8	—	—	4.22
			2	1195	36.2	26.6	9.80	4.34
			2	780	36.6	25.0	9.60	3.42
G*9V*C20	UC48C	21	1	755	27.0	—	—	4.12
			2	1330	36.6	26.8	9.60	4.34
			2	755	36.8	25.2	8.50	3.32
G*9V*C16	UC60C	21	1	810	26.6	—	—	4.12
			2	1235	36.4	26.4	9.70	4.26
			2	810	36.4	24.8	9.40	3.39
G*9V*C20	UC60C	21	1	770	26.4	—	—	4.08
			2	1325	36.6	26.4	9.70	4.34
			2	770	36.6	24.8	8.60	3.33
G*9V*D20	UC60D	24	1	830	26.6	—	—	4.14
			2	1225	36.2	26.2	9.80	4.32
			2	830	36.4	24.8	9.50	3.39

1. MC coils available with a factory installed horizontal drain pan. See price pages for specific model number.

2. Heating MBH based on ARI standards of 70° DB entering indoor air, 72% RH outdoor air with 25 feet of interconnecting piping and no supplemental electric heat operation.

3. Variable speed furnaces have B.O.D (Blower on Delay) standard.

CP equals MBH output divided by (total KW input x 3.412).

HSPF (Heating Seasonal Performance Factor) is the total heating output during a normal annual usage period for heating divided by the total electric power input during the same period.

— = Not Applicable.

HEATING CAPACITY - HC8B048F1 With Variable Speed Furnaces

VARIABLE SPEED FURNACE MODEL	COIL MODEL ¹	W	ARI HEATING ²					
			STAGE	RATED CFM	NET MBH		HSPF	COP @ 47
					47 OD	17 OD		
18 SEER HP WITH VARIABLE SPEED FURNACES³								
(F,L)C8V*C16	FC/MC/PC48C	21	1	880	35.5	—	—	3.40
			2	1500	48.0	33.0	9.30	3.80
			2	880	38.0	25.4	9.00	3.00
(F,L)C8V*C20	FC/MC/PC48C	21	1	1030	36.0	—	—	3.80
			2	1610	48.0	32.8	9.30	3.80
			2	1030	38.0	25.4	9.00	3.00
FC9(C,V)*C16	FC/MC/PC48C	21	1	1090	36.0	—	—	3.80
			2	1600	48.0	33.0	9.30	3.80
			2	1090	38.0	25.4	9.00	3.20
FC9(C,V)*C20	FC/MC/PC48C	21	1	1010	36.0	—	—	3.60
			2	1580	48.0	33.0	9.30	3.80
			2	1010	38.0	25.6	9.00	3.00
FC9(C,V)*D20	FC/MC/PC48D	24	1	985	36.0	—	—	3.60
			2	1560	48.0	32.8	9.30	3.80
			2	985	38.0	25.6	9.00	3.00
(F,L)C8V*C16	FC/PC60C	21	1	880	35.5	—	—	3.80
			2	1500	48.0	32.8	9.30	3.80
			2	880	38.5	25.6	9.00	3.00
(F,L)C8V*C20	FC/PC60C	21	1	1030	36.0	—	—	4.00
			2	1610	48.0	32.8	9.80	4.00
			2	1030	39.0	25.6	9.50	3.20
FC9(C,V)*C16	FC/PC60C	21	1	1090	37.0	—	—	3.80
			2	1600	48.0	33.0	9.80	4.00
			2	1090	40.0	26.2	9.50	3.20
FC9(C,V)*C20	FC/PC60C	21	1	1010	36.0	—	—	3.80
			2	1580	48.0	32.8	9.80	4.00
			2	1010	38.5	25.6	9.50	3.20
FC9(C,V)*D20	FC/MC/PC60D	24	1	985	36.0	—	—	3.80
			2	1560	48.0	32.6	9.80	4.00
			2	985	39.0	25.6	9.50	3.20
(F,L)C8V*C20	FC/MC62D	24	1	1030	36.0	—	—	3.80
			2	1610	48.0	32.8	9.80	4.00
			2	1030	38.5	25.2	9.50	3.20
FC9(C,V)*C20	FC/MC62D	24	1	1010	36.0	—	—	3.80
			2	1580	48.0	32.6	9.30	3.80
			2	1010	38.0	25.0	9.00	3.00
FC9(C,V)*D20	FC/MC62D	24	1	985	36.0	—	—	3.60
			2	1560	48.0	32.6	9.80	4.00
			2	985	38.0	25.0	9.50	3.20
C*(8,L)C*C16	FC/MC/PC48C	21	1	1035	35.4	—	—	3.62
			2	1615	48.5	32.6	9.50	3.80
			2	1035	37.6	31.8	9.20	3.03
C*(8,L)C*C20	FC/MC/PC48C	21	1	1080	35.4	—	—	3.60
			2	1640	48.5	32.6	9.50	3.80
			2	1080	37.7	31.8	9.10	3.03
C*9C*C16	FC/MC/PC48C	21	1	1050	37.0	—	—	3.66
			2	1590	48.5	37.2	9.40	3.76
			2	1050	38.3	37.9	9.30	3.04
C*9C*C20	FC/MC/PC48C	21	1	1055	37.0	—	—	3.68
			2	1655	48.5	37.2	9.40	3.76
			2	1055	38.2	37.9	9.30	3.05

For Notes See Page 30.

HEATING CAPACITY - HC8B048F1 With Variable Speed Furnaces (Continued)

VARIABLE SPEED FURNACE MODEL	COIL MODEL ¹	W	ARI HEATING ²					
			STAGE	RATED CFM	NET MBH		HSPF	COP @ 47
					47 OD	17 OD		
18 SEER HP WITH VARIABLE SPEED FURNACES³								
C*9C*D20	FC/MC/PC48D	24	1	1060	35.4	–	–	3.60
			2	1645	48.5	32.6	9.40	3.78
			2	1060	37.7	31.8	9.10	3.03
C*(8,L)C*C16	FC/PC60C	21	1	1035	35.4	–	–	3.66
			2	1625	48.5	32.6	9.50	3.82
			2	1035	37.5	31.8	9.20	3.12
C*(8,L)C*C20	FC/PC60C	21	1	1015	35.2	–	–	3.68
			2	1605	48.0	32.2	9.60	3.88
			2	1015	37.4	31.7	9.30	3.14
C*9C*C16	FC/PC60C	21	1	1050	35.4	–	–	3.62
			2	1590	48.5	32.6	9.40	3.80
			2	1050	37.5	31.9	9.00	3.11
C*9C*C20	FC/PC60C	21	1	1055	35.4	–	–	3.64
			2	1655	48.5	32.6	9.40	3.80
			2	1055	37.5	31.9	9.10	3.11
C*9C*D20	FC/MC/PC60D	24	1	1070	35.6	–	–	3.68
			2	1615	48.5	32.6	9.50	3.80
			2	1070	37.9	32.1	9.20	3.10
C*9C*D20	FC/MC62D	24	1	1085	35.4	–	–	3.72
			2	1630	48.5	32.4	9.50	3.86
			2	1085	37.8	31.8	9.10	3.15
C*9C*D20	HC60	24	1	1070	37.8	–	–	3.86
			2	1615	48.5	37.0	9.50	3.92
			2	1070	39.3	38.2	8.80	3.24
C*(8,L)C*C16	HD48	21	1	1035	36.2	–	–	3.26
			2	1615	48.0	36.2	9.30	3.52
			2	1035	38.0	36.6	8.20	2.67
C*(8,L)C*C20	HD48	21	1	1080	36.2	–	–	3.26
			2	1640	48.0	36.2	9.30	3.54
			2	1080	38.1	36.7	9.20	2.67
C*9C*C16	HD48	21	1	1050	36.2	–	–	3.28
			2	1590	48.0	36.2	9.30	3.50
			2	1050	38.1	36.7	8.20	2.68
C*9C*C20	HD48	21	1	1055	36.2	–	–	3.28
			2	1655	48.0	36.2	9.30	3.50
			2	1055	38.1	36.7	8.20	2.69
C*9C*D20	HD48	24	1	1060	36.2	–	–	3.26
			2	1645	48.0	36.2	9.30	3.52
			2	1060	38.1	36.7	8.20	2.67
C*(8,L)C*C16	HD60	21	1	1035	36.4	–	–	3.40
			2	1625	48.0	36.0	9.40	3.62
			2	1035	38.1	36.7	8.30	2.74
C*(8,L)C*C20	HD60	21	1	1015	36.4	–	–	3.42
			2	1605	47.5	35.8	9.50	3.66
			2	1015	38.1	36.6	8.30	2.75
C*9C*C16	HD60	21	1	1050	36.6	–	–	3.38
			2	1590	48.0	36.2	9.30	3.60
			2	1050	38.2	36.8	9.30	2.73
C*9C*C20	HD60	21	1	1055	36.4	–	–	3.38
			2	1655	48.0	36.2	9.30	3.60
			2	1055	38.2	36.8	8.20	2.73

For Notes See Page 30.

HEATING CAPACITY - HC8B048F1 With Variable Speed Furnaces (Continued)

VARIABLE SPEED FURNACE MODEL	COIL MODEL ¹	W	ARI HEATING ²					
			STAGE	RATED CFM	NET MBH		HSPF	COP @ 47
					47 OD	17 OD		
18 SEER HP WITH VARIABLE SPEED FURNACES³								
C*9C*D20	HD60	24	1	1070	36.6	–	–	3.38
			2	1615	48.0	36.2	9.40	3.60
			2	1070	38.2	36.8	9.30	2.73
C*(8,L)C*C16	UC48C	21	1	1035	37.8	–	–	3.80
			2	1615	48.5	37.0	9.50	3.88
			2	1035	39.1	38.3	8.70	3.17
C*(8,L)C*C20	UC48C	21	1	1080	37.8	–	–	3.80
			2	1640	48.5	37.0	9.50	3.88
			2	1080	39.2	38.4	8.70	3.16
C*9C*C16	UC48C	21	1	1050	37.8	–	–	3.80
			2	1590	48.5	37.0	9.50	3.86
			2	1050	39.2	38.4	8.60	3.16
C*9C*C20	UC48C	21	1	1055	37.8	–	–	3.80
			2	1655	48.5	37.0	9.50	3.86
			2	1055	39.1	38.3	8.70	3.17
C*9C*D20	UC48D	24	1	1060	37.8	–	–	3.80
			2	1645	48.5	37.0	9.50	3.86
			2	1060	39.2	38.4	8.60	3.17
C*(8,L)C*C16	UC60C	21	1	1035	37.4	–	–	3.78
			2	1625	48.5	36.6	9.60	3.90
			2	1035	39.0	37.9	8.70	3.16
C*(8,L)C*C20	UC60C	21	1	1015	37.4	–	–	3.80
			2	1605	48.5	36.4	9.70	3.94
			2	1015	39.0	37.9	8.70	3.18
C*9C*C16	UC60C	21	1	1050	37.4	–	–	3.74
			2	1590	48.5	36.8	9.50	3.86
			2	1050	39.1	38.1	8.60	3.15
C*9C*C20	UC60C	21	1	1055	37.4	–	–	3.76
			2	1655	48.5	36.8	9.50	3.86
			2	1055	39.1	38.0	8.60	3.15
C*9C*D20	UC60D	24	1	1070	37.4	–	–	3.76
			2	1615	48.5	36.6	9.50	3.88
			2	1070	39.1	38.0	8.70	3.15
G*9V*C16	FC/MC/PC48C	21	1	1050	37.0	–	–	3.66
			2	1590	48.5	37.2	9.40	3.76
			2	1050	38.3	37.9	9.30	3.04
G*9V*C20	FC/MC/PC48C	21	1	1055	37.0	–	–	3.68
			2	1655	48.5	37.2	9.40	3.76
			2	1055	38.2	37.9	9.30	3.05
G*9V*D20	FC/MC/PC48D	24	1	1060	35.4	–	–	3.60
			2	1645	48.5	32.6	9.40	3.78
			2	1060	37.7	31.8	9.10	3.03
G*9V*C16	FC/PC60C	21	1	1050	35.4	–	–	3.62
			2	1590	48.5	32.6	9.40	3.80
			2	1050	37.5	31.9	9.00	3.11
G*9V*C20	FC/PC60C	21	1	1055	35.4	–	–	3.64
			2	1655	48.5	32.6	9.40	3.80
			2	1055	37.5	31.9	9.10	3.11
G*9V*D20	FC/MC/PC60D	24	1	1070	35.6	–	–	3.68
			2	1615	48.5	32.6	9.50	3.80
			2	1070	37.9	32.1	9.20	3.10

For Notes See Page 30.

HEATING CAPACITY - HC8B048F1 With Variable Speed Furnaces (Continued)

VARIABLE SPEED FURNACE MODEL	COIL MODEL ¹	W	ARI HEATING ²					
			STAGE	RATED CFM	NET MBH		HSPF	COP @ 47
					47 OD	17 OD		
18 SEER HP WITH VARIABLE SPEED FURNACES³								
G*9V*D20	FC/MC62D	24	1	1085	35.4	—	—	3.72
			2	1630	48.5	32.4	9.50	3.86
			2	1085	37.8	31.8	9.10	3.15
G*9V*D20	HC60	24	1	1070	37.8	—	—	3.86
			2	1615	48.5	37.0	9.50	3.92
			2	1070	39.3	38.2	8.80	3.24
G*9V*C16	HD48	21	1	1050	36.2	—	—	3.28
			2	1590	48.0	36.2	9.30	3.50
			2	1050	38.1	36.7	8.20	2.68
G*9V*C20	HD48	21	1	1055	36.2	—	—	3.28
			2	1655	48.0	36.2	9.30	3.50
			2	1055	38.1	36.7	8.20	2.69
G*9V*D20	HD48	24	1	1060	36.2	—	—	3.26
			2	1645	48.0	36.2	9.30	3.52
			2	1060	38.1	36.7	8.20	2.67
G*9V*C16	HD60	21	1	1050	36.6	—	—	3.38
			2	1590	48.0	36.2	9.30	3.60
			2	1050	38.2	36.8	9.30	2.73
G*9V*C20	HD60	21	1	1055	36.4	—	—	3.38
			2	1655	48.0	36.2	9.30	3.60
			2	1055	38.2	36.8	8.20	2.73
G*9V*D20	HD60	24	1	1070	36.6	—	—	3.38
			2	1615	48.0	36.2	9.40	3.60
			2	1070	38.2	36.8	9.30	2.73
G*9V*C16	UC48C	21	1	1050	37.8	—	—	3.80
			2	1590	48.5	37.0	9.50	3.86
			2	1050	39.2	38.4	8.60	3.16
G*9V*C20	UC48C	21	1	1055	37.8	—	—	3.80
			2	1655	48.5	37.0	9.50	3.86
			2	1055	39.1	38.3	8.70	3.17
G*9V*D20	UC48D	24	1	1060	37.8	—	—	3.80
			2	1645	48.5	37.0	9.50	3.86
			2	1060	39.2	38.4	8.60	3.17
G*9V*C16	UC60C	21	1	1050	37.4	—	—	3.74
			2	1590	48.5	36.8	9.50	3.86
			2	1050	39.1	38.1	8.60	3.15
G*9V*C20	UC60C	21	1	1055	37.4	—	—	3.76
			2	1655	48.5	36.8	9.50	3.86
			2	1055	39.1	38.0	8.60	3.15
G*9V*D20	UC60D	24	1	1070	37.4	—	—	3.76
			2	1615	48.5	36.6	9.50	3.88
			2	1070	39.1	38.0	8.70	3.15

1. MC coils available with a factory installed horizontal drain pan. See price pages for specific model number.

2. Heating MBH based on ARI standards of 70° DB entering indoor air, 72% RH outdoor air with 25 feet of interconnecting piping and no supplemental electric heat operation.

3. Variable speed furnaces have B.O.D (Blower on Delay) standard.

CP equals MBH output divided by (total KW input x 3.412).

HSPF (Heating Seasonal Performance Factor) is the total heating output during a normal annual usage period for heating divided by the total electric power input during the same period.

— = Not Applicable.

HEATING CAPACITY - HC8B060F1 With Variable Speed Furnaces

VARIABLE SPEED FURNACE MODEL	COIL MODEL ¹	W	ARI HEATING ²					
			STAGE	RATED CFM	NET MBH		HSPF	COP @ 47
					47 OD	17 OD		
18 SEER HP WITH VARIABLE SPEED FURNACES³								
(F,L)C8V*C20	FC/PC60C	21	1	1120	43.0	—	—	3.40
			2	1730	58.0	39.5	9.30	3.80
			2	1120	46.5	27.2	9.00	3.00
FC9(C,V)*C20	FC/PC60C	21	1	1075	43.0	—	—	3.40
			2	1650	58.0	39.5	9.30	3.80
			2	1075	46.5	27.2	9.00	3.00
FC9(C,V)*D20	FC/MC/PC60D	24	1	1020	43.0	—	—	3.40
			2	1620	58.0	39.0	9.30	3.80
			2	1020	46.0	27.2	9.00	3.00
(F,L)C8V*C20	FC/MC62D	24	1	1120	43.0	—	—	3.40
			2	1730	58.0	39.5	9.30	3.60
			2	1120	46.0	27.0	9.00	3.00
FC9(C,V)*C20	FC/MC62D	24	1	1075	43.0	—	—	3.20
			2	1650	58.0	39.5	9.30	3.60
			2	1075	46.0	27.0	9.00	3.00
FC9(C,V)*D20	FC/MC62D	24	1	1020	43.0	—	—	3.20
			2	1620	58.0	39.0	9.30	3.80
			2	1020	46.5	27.2	9.00	3.00
C*(8,L)C*C20	FC/PC60C	21	1	1015	42.5	—	—	3.16
			2	1605	57.5	39.5	9.30	3.58
			2	1015	45.5	27.3	9.00	2.74
C*9C*C20	FC/PC60C	21	1	1055	42.5	—	—	3.14
			2	1655	58.0	39.5	9.10	3.52
			2	1055	45.6	27.4	8.80	2.73
C*(8,L)C*C20	FC/MC/PC60D	21	1	1015	42.5	—	—	3.16
			2	1605	57.5	39.5	9.30	3.58
			2	1015	45.5	27.3	9.00	2.74
C*9C*C20	FC/MC/PC60D	21	1	1055	43.0	—	—	3.14
			2	1655	58.0	39.5	9.10	3.52
			2	1055	45.6	27.4	8.80	2.73
C*9C*D20	FC/MC/PC60D	24	1	1070	43.0	—	—	3.20
			2	1615	58.0	39.5	9.20	3.54
			2	1070	45.8	27.3	8.80	2.80
C*(8,L)C*C20	FC/MC62D	21	1	1015	42.5	—	—	3.22
			2	1615	57.5	39.0	9.30	3.68
			2	1015	45.7	26.9	9.00	2.82
C*9C*C20	FC/MC62D	21	1	1040	43.0	—	—	3.20
			2	1655	58.0	39.5	9.10	3.60
			2	1040	45.7	26.9	8.90	2.81
C*9C*D20	FC/MC62D	24	1	1085	43.0	—	—	3.28
			2	1630	58.0	39.5	9.20	3.62
			2	1085	45.9	27.0	8.80	2.88
C*9C*D20	HC60	24	1	1070	43.5	—	—	3.36
			2	1615	58.0	39.5	9.20	3.68
			2	1070	46.4	27.5	9.00	2.95
C*(8,L)C*C20	HD60	21	1	1015	42.0	—	—	2.86
			2	1605	57.0	39.0	9.20	3.34
			2	1015	45.1	26.9	8.80	2.39
C*9C*C20	HD60	21	1	1055	42.0	—	—	2.90
			2	1655	57.5	39.0	9.10	3.32
			2	1055	45.0	26.9	8.60	2.47

For Notes See Page 32.

HEATING CAPACITY - HC8B060F1 With Variable Speed Furnaces (Continued)

VARIABLE SPEED FURNACE MODEL	COIL MODEL ¹	W	ARI HEATING ²					
			STAGE	RATED CFM	NET MBH		HSPF	COP @ 47
					47 OD	17 OD		
18 SEER HP WITH VARIABLE SPEED FURNACES³								
C*9C*D20	HD60	24	1	1070	42.0	—	—	2.92
			2	1615	57.5	39.0	9.10	3.30
			2	1070	45.4	27.0	8.70	2.47
C*(8,L)C*C20	UC60C	21	1	1015	43.0	—	—	3.26
			2	1605	57.5	39.0	9.30	3.66
			2	1015	46.1	27.3	9.10	2.84
C*9C*C20	UC60C	21	1	1055	43.0	—	—	3.24
			2	1655	58.0	39.5	9.20	3.60
			2	1055	46.2	27.4	9.00	2.83
C*9C*D20	UC60D	24	1	1070	43.0	—	—	3.28
			2	1615	58.0	39.5	9.20	3.62
			2	1070	46.4	27.4	9.00	2.89
G*9V*C20	FC/PC60C	21	1	1055	42.5	—	—	3.14
			2	1655	58.0	39.5	9.10	3.52
			2	1055	45.6	27.4	8.80	2.73
G*9V*C20	FC/MC/PC60D	21	1	1055	43.0	—	—	3.14
			2	1655	58.0	39.5	9.10	3.52
			2	1055	45.6	27.4	8.80	2.73
G*9V*D20	FC/MC/PC60D	24	1	1070	43.0	—	—	3.20
			2	1615	58.0	39.5	9.20	3.54
			2	1070	45.8	27.3	8.80	2.80
G*9V*C20	FC/MC62D	21	1	1040	43.0	—	—	3.20
			2	1655	58.0	39.5	9.10	3.60
			2	1040	45.7	26.9	8.90	2.81
G*9V*D20	FC/MC62D	24	1	1085	43.0	—	—	3.28
			2	1630	58.0	39.5	9.20	3.62
			2	1085	45.9	27.0	8.80	2.88
G*9V*D20	HC60	24	1	1070	43.5	—	—	3.36
			2	1615	58.0	39.5	9.20	3.68
			2	1070	46.4	27.5	9.00	2.95
G*9V*C20	HD60	21	1	1055	42.0	—	—	2.90
			2	1655	57.5	39.0	9.10	3.32
			2	1055	45.0	26.9	8.60	2.47
G*9V*D20	HD60	24	1	1070	42.0	—	—	2.92
			2	1615	57.5	39.0	9.10	3.30
			2	1070	45.4	27.0	8.70	2.47
G*9V*C20	UC60C	21	1	1055	43.0	—	—	3.24
			2	1655	58.0	39.5	9.20	3.60
			2	1055	46.2	27.4	9.00	2.83
G*9V*D20	UC60D	24	1	1070	43.0	—	—	3.28
			2	1615	58.0	39.5	9.20	3.62
			2	1070	46.4	27.4	9.00	2.89

1. MC coils available with a factory installed horizontal drain pan. See price pages for specific model number.

2. Heating MBH based on ARI standards of 70° DB entering indoor air, 72% RH outdoor air with 25 feet of interconnecting piping and no supplemental electric heat operation.

3. Variable speed furnaces have B.O.D (Blower on Delay) standard.

CP equals MBH output divided by (total KW input x 3.412).

HSPF (Heating Seasonal Performance Factor) is the total heating output during a normal annual usage period for heating divided by the total electric power input during the same period.

— = Not Applicable.

ACCESSORIES*

TXV Kits - 1TVM9 series thermal expansion valves precisely meter refrigerant for optimum performance.

Bonnet Sensor (2SB13700124) - The bonnet sensor is used to sense plenum temperature, and is optional with a gas or oil back-up heat source. Compatible only with 13 SEER and higher heat pumps.

Dehumidistat (2HU16700124) - Provides increased dehumidification when matched with variable speed furnace or air handler.

Heat Pump Risers - (526-35389-000, 526-35390-000, 526-35391-000) - 3", 6", or 12" risers mount easily in composite base pan recesses, ensuring the unit stays clear of snow and ice build-up in harsh winter weather.

Room Thermostats - A wide selection of matching thermostats is available to provide features required for any installation.

3H/2C, non-programmable digital thermostat.

3H/2C, auto/manual changeover, electronic programmable, 7-day, thermostat.

* For the most current accessory information, refer to the price book or consult factory.

SOUND POWER RATINGS*

UNIT MODEL	(dBA)	
	Cooling	Heating
024	71	72
036	72	73
048	72	73
060	73	74

* Rated in accordance with ARI 270-95 Standards.

COOLING PERFORMANCE DATA - LOW CFM 1-STAGE OPERATION																
OUTDOOR UNIT MODEL NO.		HC8B024F1														
INDOOR COIL MODEL NO.		FC/MC/PC48D + MV12D														
CONDENSER ENTERING AIR TEMPERATURE	ID CFM	600					650					700				
	ID DB (°F)	80	80	75	80	80	80	80	75	80	80	80	80	75	80	80
	ID WB (°F)	57	62	62	67	72	57	62	62	67	72	57	62	62	67	72
65	T.C.	19.7	20.0	19.9	22.0	23.6	19.7	20.0	19.9	22.0	23.6	19.7	20.0	19.9	22.0	23.6
	S.C.	19.7	19.2	15.7	15.8	13.0	19.7	19.2	15.7	15.8	13.0	19.7	19.2	15.7	15.8	13.0
	K.W.	0.8	0.8	0.8	0.8	0.8	0.8	0.8	0.8	0.8	0.8	0.8	0.8	0.8	0.8	0.8
75	T.C.	18.9	19.0	18.9	21.0	22.6	18.9	19.0	18.9	21.0	22.6	18.9	19.0	18.9	21.0	22.6
	S.C.	18.9	18.5	15.4	15.4	12.5	18.9	18.5	15.4	15.4	12.5	18.9	18.5	15.4	15.4	12.5
	K.W.	0.9	0.9	0.9	0.9	0.9	0.9	0.9	0.9	0.9	0.9	0.9	0.9	0.9	0.9	0.9
85	T.C.	18.1	18.0	18.0	20.0	21.7	18.1	18.0	18.0	20.0	21.7	18.1	18.0	18.0	20.0	21.7
	S.C.	18.1	17.7	15.0	15.0	12.1	18.1	17.7	15.0	15.0	12.1	18.1	17.7	15.0	15.0	12.1
	K.W.	1.0	1.0	1.1	1.1	1.1	1.0	1.0	1.1	1.1	1.1	1.0	1.0	1.1	1.1	1.1
95	T.C.	17.4	17.0	17.1	18.9	20.7	17.4	17.0	17.1	18.9	20.7	17.4	17.0	17.1	18.9	20.7
	S.C.	17.4	17.0	14.6	14.6	11.7	17.4	17.0	14.6	14.6	11.7	17.4	17.0	14.6	14.6	11.7
	K.W.	1.2	1.2	1.2	1.2	1.2	1.2	1.2	1.2	1.2	1.2	1.2	1.2	1.2	1.2	1.2
105	T.C.	16.2	15.9	15.6	17.4	19.1	16.2	15.9	15.6	17.4	19.1	16.2	15.9	15.6	17.4	19.1
	S.C.	16.2	15.9	13.9	14.0	11.1	16.2	15.9	13.9	14.0	11.1	16.2	15.9	13.9	14.0	11.1
	K.W.	1.4	1.4	1.4	1.4	1.4	1.4	1.4	1.4	1.4	1.4	1.4	1.4	1.4	1.4	1.4
115	T.C.	15.0	14.9	14.1	15.9	17.6	15.0	14.9	14.1	15.9	17.6	15.0	14.9	14.1	15.9	17.6
	S.C.	15.0	14.9	13.3	13.5	10.5	15.0	14.9	13.3	13.5	10.5	15.0	14.9	13.3	13.5	10.5
	K.W.	1.6	1.6	1.5	1.6	1.6	1.6	1.6	1.5	1.6	1.6	1.6	1.6	1.5	1.6	1.6
125	T.C.	13.8	13.8	12.7	14.3	16.0	13.8	13.8	12.7	14.3	16.0	13.8	13.8	12.7	14.3	16.0
	S.C.	13.8	13.8	12.7	13.0	10.0	13.8	13.8	12.7	13.0	10.0	13.8	13.8	12.7	13.0	10.0
	K.W.	1.7	1.7	1.7	1.7	1.7	1.7	1.7	1.7	1.7	1.7	1.7	1.7	1.7	1.7	1.7

NOTE: ALL CAPACITIES ARE NET (KBTUH) WITH INDOOR FAN HEAT ALREADY DEDUCTED AT 1250 BTUH/1000 CFM.

Multipliers for determining the performance with other indoor sections.

NOTE: For dry bulb temperatures different than those listed (between 73-87 F), sensible capacity increases by 1060 BTUH per 1000 CFM per degree above the listed temperature and decreases by 1060 BTUH per 1000 CFM per degree below the listed temperature.

NOTE: KW RATING IS FOR OUTDOOR AND INDOOR UNITS.

LOW CFM

Air Handler	Coil	T.C.	S.C.	KW
AV36	-	0.98	0.96	0.98
MV12B	FC/MC43B	0.98	0.96	0.97
MV12D	FC/MC60D	1.00	1.00	1.00

Variable Speed Furnace	Coil	T.C.	S.C.	KW
FC9(C,V)*B12	FC/MC/PC43B	0.97	0.92	0.97
C*(8,L)C*A12	FC/MC/PC30A	0.97	0.93	1.01
C*(8,L)C*B12	FC/MC/PC30B	0.96	0.91	0.99
C*9C*B12	FC/MC/PC30B	0.96	0.91	1.00
C*(8,L)C*A12	FC/MC/PC32A	0.94	0.89	1.01
C*(8,L)C*B12	FC/MC/PC35B	0.94	0.86	0.99
C*9C*B12	FC/MC/PC35B	0.94	0.89	1.00
C*(8,L)C*A12	FC/MC/PC36A	0.96	0.93	1.00
C*(8,L)C*B12	FC/MC/PC36B	0.95	0.88	0.99
C*9C*B12	FC/MC/PC36B	0.96	0.93	1.00
C*(8,L)C*A12	FC/MC/PC37A	0.97	0.93	1.01
C*(8,L)C*B12	FC/MC/PC43B	0.95	0.87	0.99
C*9C*B12	FC/MC/PC43B	0.96	0.90	1.00
C*(8,L)C*A12	HC30	0.95	0.89	1.01
C*(8,L)C*A12	HD36	0.95	0.89	1.00
C*(8,L)C*B12	HD36	0.92	0.83	0.99

Variable Speed Furnace	Coil	T.C.	S.C.	KW
C*9C*B12	HD36	0.95	0.89	1.00
C*(8,L)C*A12	UC30A	0.97	0.93	1.01
C*(8,L)C*B12	UC30B	0.97	0.92	0.99
C*9C*B12	UC30B	0.96	0.92	1.00
C*(8,L)C*A12	UC36A	0.96	0.92	1.00
C*(8,L)C*B12	UC36B	0.94	0.87	0.99
C*9C*B12	UC36B	0.96	0.92	1.00
G*9V*A12	FC/MC/PC30A	0.96	0.95	1.03
G*9V*B12	FC/MC/PC30B	0.96	0.91	1.00
G*9V*A12	FC/MC/PC32A	0.97	0.95	1.03
G*9V*B12	FC/MC/PC35B	0.94	0.89	1.00
G*9V*A12	FC/MC/PC36A	0.97	0.95	1.03
G*9V*B12	FC/MC/PC36B	0.96	0.93	1.00
G*9V*A12	FC/MC/PC37A	0.95	0.88	1.02
G*9V*B12	FC/MC/PC43B	0.96	0.90	1.00
G*9V*A12	HC30	0.97	0.94	1.03
G*9V*A12	HD36	0.95	0.90	1.03
G*9V*B12	HD36	0.95	0.89	1.00
G*9V*A12	UC30A	0.97	0.95	1.03
G*9V*B12	UC30B	0.96	0.92	1.00
G*9V*A12	UC36A	0.96	0.94	1.03
G*9V*B12	UC36B	0.96	0.92	1.00

COOLING PERFORMANCE DATA - HIGH CFM 2-STAGE OPERATION																
OUTDOOR UNIT MODEL NO.		HC8B024F1														
INDOOR COIL MODEL NO.		FC/MC/PC48D + MV12D														
CONDENSER ENTERING AIR TEMPERATURE	ID CFM	740					840					940				
	ID DB (°F)	80	80	75	80	80	80	80	75	80	80	80	80	75	80	80
	ID WB (°F)	57	62	62	67	72	57	62	62	67	72	57	62	62	67	72
65	T.C.	24.9	26.6	26.4	28.8	30.9	25.8	27.2	26.9	29.3	31.6	26.7	27.8	27.4	29.8	32.2
	S.C.	24.9	23.2	19.7	19.3	16.3	25.8	24.9	20.8	20.5	16.8	26.7	26.6	21.8	21.6	17.4
	K.W.	1.2	1.2	1.2	1.2	1.2	1.2	1.2	1.2	1.2	1.2	1.2	1.2	1.2	1.2	1.2
75	T.C.	24.0	25.3	25.2	27.5	29.6	24.9	25.8	25.7	28.0	30.2	25.8	26.4	26.2	28.5	30.9
	S.C.	24.0	22.6	19.1	18.8	15.7	24.9	24.1	20.2	20.0	16.2	25.8	25.6	21.3	21.1	16.8
	K.W.	1.4	1.4	1.4	1.4	1.4	1.4	1.4	1.4	1.4	1.4	1.4	1.4	1.4	1.4	1.4
85	T.C.	23.1	24.0	24.0	26.2	28.3	24.0	24.5	24.4	26.7	28.9	24.9	25.0	24.9	27.2	29.5
	S.C.	23.1	22.0	18.5	18.4	15.0	24.0	23.3	19.6	19.5	15.6	24.9	24.6	20.7	20.6	16.2
	K.W.	1.5	1.5	1.5	1.5	1.6	1.5	1.5	1.5	1.5	1.6	1.5	1.5	1.5	1.6	1.6
95	T.C.	22.1	22.7	22.8	24.9	26.9	23.1	23.1	23.2	25.4	27.6	24.0	23.6	23.7	25.9	28.2
	S.C.	22.1	21.4	18.0	17.9	14.4	23.1	22.5	19.1	19.0	15.0	24.0	23.6	20.2	20.0	15.6
	K.W.	1.7	1.7	1.7	1.7	1.7	1.7	1.7	1.7	1.7	1.7	1.7	1.7	1.7	1.7	1.7
105	T.C.	20.9	21.2	21.1	23.3	25.3	21.8	21.8	21.5	23.7	25.8	22.6	22.4	21.9	24.1	26.3
	S.C.	20.9	20.4	17.2	17.2	13.7	21.8	21.4	18.3	18.3	14.3	22.6	22.4	19.5	19.4	14.9
	K.W.	1.9	1.9	1.9	1.9	1.9	1.9	1.9	1.9	1.9	2.0	1.9	1.9	1.9	1.9	2.0
115	T.C.	19.7	19.8	19.5	21.8	23.6	20.5	20.5	19.9	22.1	24.0	21.3	21.2	20.3	22.4	24.5
	S.C.	19.7	19.4	16.5	16.6	13.0	20.5	20.3	17.6	17.6	13.6	21.3	21.2	18.8	18.7	14.2
	K.W.	2.1	2.1	2.1	2.1	2.2	2.1	2.1	2.1	2.1	2.2	2.1	2.1	2.1	2.1	2.2
125	T.C.	18.5	18.4	17.9	20.2	22.0	19.3	19.2	18.3	20.4	22.3	20.0	20.0	18.6	20.7	22.6
	S.C.	18.5	18.4	15.8	15.9	12.2	19.3	19.2	16.9	17.0	12.9	20.0	20.0	18.1	18.1	13.5
	K.W.	2.3	2.3	2.3	2.4	2.4	2.3	2.3	2.3	2.4	2.4	2.4	2.4	2.3	2.4	2.4

NOTE: ALL CAPACITIES ARE NET (KBTUH) WITH INDOOR FAN HEAT ALREADY DEDUCTED AT 1250 BTUH/1000 CFM.

Multipliers for determining the performance with other indoor sections.

NOTE: For dry bulb temperatures different than those listed (between 73-87 F), sensible capacity increases by 1060 BTUH per 1000 CFM per degree above the listed temperature and decreases by 1060 BTUH per 1000 CFM per degree below the listed temperature.

NOTE: KW RATING IS FOR OUTDOOR AND INDOOR UNITS.

HIGH CFM

Air Handler	Coil	T.C.	S.C.	KW
AV36	-	0.98	0.95	0.98
MV12B	FC/MC43B	0.98	0.96	0.97
MV12D	FC/MC60D	1.00	1.00	1.00

Variable Speed Furnace	Coil	T.C.	S.C.	KW
FC9(C,V)*B12	FC/MC/PC43B	0.98	0.97	0.95
C*(8,L)C*A12	FC/MC/PC30A	0.96	0.94	1.02
C*(8,L)C*B12	FC/MC/PC30B	0.96	0.94	1.00
C*9C*B12	FC/MC/PC30B	0.96	0.94	1.02
C*(8,L)C*A12	FC/MC/PC32A	0.96	0.93	1.03
C*(8,L)C*B12	FC/MC/PC35B	0.96	0.92	1.01
C*9C*B12	FC/MC/PC35B	0.97	0.95	1.03
C*(8,L)C*A12	FC/MC/PC36A	0.97	0.95	1.02
C*(8,L)C*B12	FC/MC/PC36B	0.96	0.92	1.00
C*9C*B12	FC/MC/PC36B	0.98	0.95	1.01
C*(8,L)C*A12	FC/MC/PC37A	0.98	0.96	1.03
C*(8,L)C*B12	FC/MC/PC43B	0.97	0.94	1.01
C*9C*B12	FC/MC/PC43B	0.98	0.96	1.02
C*(8,L)C*A12	HC30	0.95	0.92	1.02
C*(8,L)C*A12	HD36	0.96	0.91	1.01
C*(8,L)C*B12	HD36	0.94	0.88	1.00

Variable Speed Furnace	Coil	T.C.	S.C.	KW
C*9C*B12	HD36	0.96	0.91	1.01
C*(8,L)C*A12	UC30A	0.97	0.95	1.02
C*(8,L)C*B12	UC30B	0.97	0.95	1.00
C*9C*B12	UC30B	0.97	0.95	1.02
C*(8,L)C*A12	UC36A	0.97	0.95	1.02
C*(8,L)C*B12	UC36B	0.96	0.92	1.00
C*9C*B12	UC36B	0.97	0.95	1.01
G*9V*A12	FC/MC/PC30A	0.96	0.93	1.03
G*9V*B12	FC/MC/PC30B	0.96	0.94	1.02
G*9V*A12	FC/MC/PC32A	0.97	0.94	1.05
G*9V*B12	FC/MC/PC35B	0.97	0.95	1.03
G*9V*A12	FC/MC/PC36A	0.97	0.94	1.03
G*9V*B12	FC/MC/PC36B	0.98	0.95	1.01
G*9V*A12	FC/MC/PC37A	0.97	0.95	1.04
G*9V*B12	FC/MC/PC43B	0.98	0.96	1.02
G*9V*A12	HC30	0.96	0.93	1.03
G*9V*A12	HD36	0.95	0.90	1.03
G*9V*B12	HD36	0.96	0.91	1.01
G*9V*A12	UC30A	0.97	0.94	1.03
G*9V*B12	UC30B	0.97	0.95	1.02
G*9V*A12	UC36A	0.96	0.93	1.03
G*9V*B12	UC36B	0.97	0.95	1.01

COOLING PERFORMANCE DATA - LOW CFM 1-STAGE OPERATION																
OUTDOOR UNIT MODEL NO.		HC8B036F1														
INDOOR COIL MODEL NO.		FC/MC62D + MV12D														
CONDENSER ENTERING AIR TEMPERATURE	ID CFM	796					846					896				
	ID DB (°F)	80	80	75	80	80	80	80	75	80	80	80	80	75	80	80
	ID WB (°F)	57	62	62	67	72	57	62	62	67	72	57	62	62	67	72
65	T.C.	26.3	27.5	27.3	30.5	33.5	26.9	28.0	27.7	30.9	34.1	27.4	28.4	28.1	31.3	34.7
	S.C.	26.3	23.9	20.3	20.4	16.7	26.9	25.0	20.9	21.0	17.1	27.4	26.1	21.6	21.6	17.5
	K.W.	1.0	1.0	1.0	1.0	1.1	1.0	1.0	1.0	1.0	1.1	1.0	1.0	1.0	1.0	1.1
75	T.C.	25.2	26.0	25.9	28.9	32.0	25.7	26.4	26.3	29.3	32.5	26.3	26.7	26.6	29.7	33.0
	S.C.	25.2	23.6	19.8	19.8	16.1	25.7	24.4	20.4	20.5	16.5	26.3	25.2	21.0	21.1	16.9
	K.W.	1.2	1.2	1.2	1.2	1.2	1.2	1.2	1.2	1.2	1.2	1.2	1.2	1.2	1.2	1.2
85	T.C.	24.1	24.5	24.5	27.4	30.5	24.6	24.8	24.8	27.8	30.8	25.2	25.0	25.1	28.1	31.2
	S.C.	24.1	23.2	19.3	19.3	15.5	24.6	23.8	19.9	19.9	15.9	25.2	24.3	20.5	20.5	16.3
	K.W.	1.4	1.4	1.4	1.4	1.4	1.4	1.4	1.4	1.4	1.4	1.4	1.4	1.4	1.4	1.4
95	T.C.	23.0	22.9	23.0	25.9	28.9	23.5	23.1	23.3	26.2	29.2	24.0	23.4	23.6	26.5	29.5
	S.C.	23.0	22.9	18.7	18.8	15.0	23.5	23.1	19.3	19.4	15.3	24.0	23.4	19.9	20.0	15.6
	K.W.	1.6	1.6	1.6	1.6	1.6	1.6	1.6	1.6	1.6	1.6	1.6	1.6	1.6	1.6	1.6
105	T.C.	21.4	21.3	20.8	23.6	26.6	21.8	21.6	21.1	23.8	26.8	22.3	21.9	21.3	24.1	27.0
	S.C.	21.4	21.3	17.9	18.0	14.2	21.8	21.6	18.4	18.6	14.5	22.3	21.9	18.9	19.2	14.9
	K.W.	1.8	1.8	1.8	1.8	1.9	1.8	1.8	1.8	1.8	1.9	1.8	1.8	1.8	1.8	1.9
115	T.C.	19.8	19.7	18.7	21.3	24.3	20.2	20.1	18.9	21.5	24.5	20.6	20.4	19.1	21.8	24.7
	S.C.	19.8	19.7	17.1	17.3	13.4	20.2	20.1	17.5	17.9	13.8	20.6	20.4	17.9	18.5	14.1
	K.W.	2.1	2.1	2.1	2.1	2.1	2.1	2.1	2.1	2.1	2.1	2.1	2.1	2.1	2.1	2.1
125	T.C.	18.2	18.2	16.5	19.1	22.0	18.6	18.6	16.7	19.2	22.1	19.0	19.0	16.9	19.4	22.3
	S.C.	18.2	18.2	16.4	16.5	12.6	18.6	18.6	16.6	17.1	13.0	19.0	19.0	16.9	17.7	13.4
	K.W.	2.3	2.3	2.3	2.3	2.3	2.3	2.3	2.3	2.3	2.3	2.3	2.3	2.3	2.3	2.3

NOTE: ALL CAPACITIES ARE NET (KBTUH) WITH INDOOR FAN HEAT ALREADY DEDUCTED AT 1250 BTUH/1000 CFM.

Multipliers for determining the performance with other indoor sections.

NOTE: For dry bulb temperatures different than those listed (between 73-87 F), sensible capacity increases by 1060 BTUH per 1000 CFM per degree above the listed temperature and decreases by 1060 BTUH per 1000 CFM per degree below the listed temperature.

NOTE: KW RATING IS FOR OUTDOOR AND INDOOR UNITS.

LOW CFM

Air Handler	Coil	T.C.	S.C.	KW
AV36	-	0.98	0.97	0.97
AV/SV48	-	1.01	1.04	0.98
MV16C	FC/MC43C	0.97	0.93	0.95
MV16C	FC/MC48C	0.98	0.95	0.96
MV12D	FC/MC48D	0.97	0.91	0.96
MV12D	FC/MC60D	0.97	0.93	0.97

Variable Speed Furnace	Coil	T.C.	S.C.	KW
(F,L)C8V*B16	FC/MC/PC43B	0.96	0.92	0.95
(F,L)C8V*C16	FC/MC/PC43C	0.93	0.84	0.94
(F,L)C8V*C20	FC/MC/PC43C	0.96	0.93	0.94
FC9(C,V)*B12	FC/MC/PC43B	0.96	0.93	0.94
FC9(C,V)*C16	FC/MC/PC43C	0.97	0.93	0.97
FC9(C,V)*C20	FC/MC/PC43C	0.97	0.94	0.95
(F,L)C8V*C16	FC/MC/PC48C	0.94	0.86	0.95
(F,L)C8V*C20	FC/MC/PC48C	0.97	0.94	0.95
FC9(C,V)*C16	FC/MC/PC48C	0.98	0.94	0.97
FC9(C,V)*C20	FC/MC/PC48C	0.98	0.95	0.95
FC9(C,V)*D20	FC/MC/PC48D	0.98	0.95	0.96
(F,L)C8V*C16	FC/PC60C	0.95	0.87	0.96
(F,L)C8V*C20	FC/PC60C	0.98	0.96	0.96
FC9(C,V)*C16	FC/PC60C	0.98	0.95	0.97
FC9(C,V)*C20	FC/PC60C	0.98	0.96	0.96
FC9(C,V)*D20	FC/MC/PC60D	0.97	0.95	0.96
(F,L)C8V*C20	FC/MC62D	0.97	0.94	0.96
FC9(C,V)*C20	FC/MC62D	0.98	0.95	0.96
FC9(C,V)*D20	FC/MC62D	0.98	0.95	0.96
(F,L)C8V*C16	HC42	0.93	0.85	0.94

Continued on Page 37.

Variable Speed Furnace	Coil	T.C.	S.C.	KW
(F,L)C8V*C20	HC42	0.96	0.93	0.95
FC9(C,V)*C16	HC42	0.97	0.93	0.97
FC9(C,V)*C20	HC42	0.98	0.94	0.95
C*(8,L)C*B12	FC/MC/PC35B	0.95	0.90	1.02
C*(8,L)C*C16	FC/MC/PC35C	0.97	0.94	1.02
C*(8,L)C*C20	FC/MC/PC35C	0.99	1.05	1.06
C*9C*B12	FC/MC/PC35B	0.96	0.94	1.04
C*9C*C16	FC/MC/PC35C	0.96	0.93	1.02
C*9C*C20	FC/MC/PC35C	0.95	0.91	1.02
C*(8,L)C*A12	FC/MC/PC36A	0.96	0.93	1.04
C*(8,L)C*B12	FC/MC/PC36B	0.94	0.90	1.01
C*(8,L)C*C16	FC/MC/PC36C	0.96	0.93	1.01
C*(8,L)C*C20	FC/MC/PC36C	0.96	0.93	1.01
C*9C*B12	FC/MC/PC36B	0.95	0.92	1.03
C*9C*C16	FC/MC/PC36C	0.98	0.98	1.04
C*9C*C20	FC/MC/PC36C	0.95	0.91	1.01
C*(8,L)C*A12	FC/MC/PC37A	0.94	0.86	1.01
C*(8,L)C*B12	FC/MC/PC42B	0.97	0.93	1.01
C*(8,L)C*C16	FC/MC/PC42C	0.98	0.97	1.01
C*(8,L)C*C20	FC/MC/PC42C	0.96	0.91	1.00
C*9C*B12	FC/MC/PC42B	0.98	0.95	1.04
C*9C*C16	FC/MC/PC42C	0.97	0.94	1.02
C*9C*C20	FC/MC/PC42C	0.97	0.94	1.02
C*(8,L)C*B12	FC/MC/PC43B	0.96	0.92	1.02
C*(8,L)C*C16	FC/MC/PC43C	0.98	0.95	1.02
C*(8,L)C*C20	FC/MC/PC43C	0.97	0.92	1.01
C*9C*B12	FC/MC/PC43B	0.98	0.96	1.04
C*9C*C16	FC/MC/PC43C	0.98	0.96	1.03
C*9C*C20	FC/MC/PC43C	0.97	0.94	1.02
C*(8,L)C*C16	FC/MC/PC48C	0.96	0.95	1.00
C*(8,L)C*C20	FC/MC/PC48C	0.94	0.90	0.99
C*9C*C16	FC/MC/PC48C	0.96	0.95	1.01
C*9C*C20	FC/MC/PC48C	0.95	0.91	1.01
C*(8,L)C*C16	FC/PC60C	0.96	0.96	1.00
C*(8,L)C*C20	FC/PC60C	0.95	0.95	1.00
C*9C*C16	FC/PC60C	0.95	0.95	1.02
C*9C*C20	FC/PC60C	0.95	0.93	1.01
C*9C*D20	FC/MC/PC60D	0.95	0.96	1.01
C*9C*D20	FC/MC62D	1.00	0.99	1.02
C*(8,L)C*C16	HC42	0.98	0.95	1.02
C*(8,L)C*C20	HC42	0.97	0.92	1.01
C*9C*C16	HC42	0.98	0.96	1.03
C*9C*C20	HC42	0.98	0.94	1.02
C*(8,L)C*B12	HD48	0.96	0.92	1.01
C*(8,L)C*C16	HD48	0.97	0.95	1.01
C*(8,L)C*C20	HD48	0.96	0.90	1.00
C*9C*B12	HD48	0.95	0.89	1.02
C*9C*C16	HD48	0.96	0.93	1.01
C*9C*C20	HD48	0.96	0.92	1.01
C*(8,L)C*A12	UC36A	0.96	0.93	1.04
C*(8,L)C*B12	UC36B	0.94	0.90	1.01
C*(8,L)C*C16	UC36C	0.96	0.93	1.01
C*(8,L)C*C20	UC36C	0.96	0.93	1.01
C*9C*B12	UC36B	0.95	0.92	1.03

Variable Speed Furnace	Coil	T.C.	S.C.	KW
C*9C*C16	UC36C	0.97	0.98	1.04
C*9C*C20	UC36C	0.95	0.91	1.01
C*(8,L)C*B12	UC42B	0.95	0.91	1.01
C*(8,L)C*C16	UC42C	0.96	0.95	1.01
C*(8,L)C*C20	UC42C	0.94	0.89	1.00
C*9C*B12	UC42B	0.95	0.92	1.03
C*9C*C16	UC42C	0.95	0.92	1.01
C*9C*C20	UC42C	0.95	0.91	1.01
C*(8,L)C*C16	UC48C	0.98	0.97	1.01
C*(8,L)C*C20	UC48C	0.96	0.92	1.00
C*9C*C16	UC48C	0.98	0.95	1.02
C*9C*C20	UC48C	0.97	0.93	1.02
C*(8,L)C*C16	UC60C	0.98	0.95	1.01
C*(8,L)C*C20	UC60C	0.98	0.95	1.01
C*9C*C16	UC60C	0.98	0.95	1.03
C*9C*C20	UC60C	0.97	0.93	1.02
C*9C*D20	UC60D	0.98	0.95	1.02
G*9V*B12	FC/MC/PC35B	0.96	0.94	1.04
G*9V*C16	FC/MC/PC35C	0.96	0.93	1.02
G*9V*C20	FC/MC/PC35C	0.95	0.91	1.02
G*9V*B12	FC/MC/PC36B	0.95	0.92	1.03
G*9V*A12	FC/MC/PC36A	0.95	0.91	1.04
G*9V*C16	FC/MC/PC36C	0.98	0.98	1.04
G*9V*C20	FC/MC/PC36C	0.95	0.91	1.01
G*9V*B12	FC/MC/PC42B	0.98	0.95	1.04
G*9V*C16	FC/MC/PC42C	0.97	0.94	1.02
G*9V*C20	FC/MC/PC42C	0.97	0.94	1.02
G*9V*A12	FC/MC/PC37A	0.97	0.94	1.05
G*9V*B12	FC/MC/PC43B	0.98	0.96	1.04
G*9V*C16	FC/MC/PC43C	0.98	0.96	1.03
G*9V*C20	FC/MC/PC43C	0.97	0.94	1.02
G*9V*C16	FC/MC/PC48C	0.96	0.95	1.01
G*9V*C20	FC/MC/PC48C	0.95	0.91	1.01
G*9V*C16	FC/PC60C	0.95	0.95	1.02
G*9V*C20	FC/PC60C	0.95	0.93	1.01
G*9V*D20	FC/MC/PC60D	0.95	0.96	1.01
G*9V*D20	FC/MC62D	1.00	0.99	1.02
G*9V*C16	HC42	0.98	0.96	1.03
G*9V*C20	HC42	0.98	0.94	1.02
G*9V*B12	HD48	0.95	0.89	1.02
G*9V*C16	HD48	0.96	0.93	1.01
G*9V*C20	HD48	0.96	0.92	1.01
G*9V*A12	UC36A	0.95	0.91	1.04
G*9V*B12	UC36B	0.95	0.92	1.03
G*9V*C16	UC36C	0.97	0.98	1.04
G*9V*C20	UC36C	0.95	0.91	1.01
G*9V*B12	UC42B	0.95	0.92	1.03
G*9V*C16	UC42C	0.95	0.92	1.01
G*9V*C20	UC42C	0.95	0.91	1.01
G*9V*C16	UC48C	0.98	0.95	1.02
G*9V*C20	UC48C	0.97	0.93	1.02
G*9V*C16	UC60C	0.98	0.95	1.03
G*9V*C20	UC60C	0.97	0.93	1.02
G*9V*D20	UC60D	0.98	0.95	1.02

COOLING PERFORMANCE DATA - HIGH CFM 2-STAGE OPERATION																
OUTDOOR UNIT MODEL NO.		HC8B036F1														
INDOOR COIL MODEL NO.		FC/MC62D + MV12D														
CONDENSER ENTERING AIR TEMPERATURE	ID CFM	1148					1248					1348				
	ID DB (°F)	80	80	75	80	80	80	80	75	80	80	80	80	75	80	80
	ID WB (°F)	57	62	62	67	72	57	62	62	67	72	57	62	62	67	72
65	T.C.	38.4	39.7	40.2	43.7	47.8	39.4	40.6	40.8	44.4	48.5	40.5	41.5	41.3	45.2	49.1
	S.C.	38.4	35.1	30.0	29.8	24.1	39.4	37.0	31.1	30.9	24.9	40.5	38.8	32.2	32.0	25.7
	K.W.	1.7	1.7	1.7	1.8	1.8	1.7	1.7	1.7	1.8	1.8	1.7	1.8	1.8	1.8	1.8
75	T.C.	37.0	38.0	38.2	41.8	45.7	38.0	38.7	38.8	42.4	46.3	39.0	39.4	39.3	43.0	46.9
	S.C.	37.0	34.5	29.3	29.1	23.4	38.0	36.1	30.4	30.2	24.1	39.0	37.7	31.5	31.3	24.8
	K.W.	2.0	2.0	2.0	2.0	2.0	2.0	2.0	2.0	2.0	2.0	2.0	2.0	2.0	2.0	2.1
85	T.C.	35.6	36.2	36.3	39.9	43.6	36.5	36.8	36.8	40.4	44.1	37.4	37.4	37.3	40.9	44.6
	S.C.	35.6	33.9	28.6	28.4	22.6	36.5	35.2	29.7	29.4	23.3	37.4	36.5	30.8	30.5	24.0
	K.W.	2.2	2.2	2.2	2.2	2.3	2.2	2.2	2.2	2.2	2.3	2.2	2.2	2.2	2.3	2.3
95	T.C.	34.2	34.5	34.3	37.9	41.5	35.0	34.9	34.8	38.3	41.9	35.8	35.3	35.3	38.7	42.4
	S.C.	34.2	33.3	27.8	27.7	21.9	35.0	34.3	28.9	28.7	22.5	35.8	35.3	30.0	29.7	23.2
	K.W.	2.4	2.4	2.4	2.5	2.5	2.4	2.4	2.4	2.5	2.5	2.5	2.4	2.4	2.5	2.5
105	T.C.	32.2	32.4	31.9	35.3	38.7	33.0	32.9	32.3	35.7	39.1	33.8	33.5	32.7	36.0	39.5
	S.C.	32.2	31.6	26.9	26.7	20.9	33.0	32.5	28.0	27.8	21.5	33.8	33.5	29.1	28.8	22.2
	K.W.	2.7	2.7	2.7	2.8	2.8	2.8	2.8	2.7	2.8	2.8	2.8	2.8	2.8	2.8	2.8
115	T.C.	30.3	30.4	29.6	32.7	36.0	31.1	31.0	29.9	33.1	36.4	31.9	31.6	30.3	33.4	36.7
	S.C.	30.3	30.0	26.0	25.8	19.9	31.1	30.8	27.1	26.9	20.6	31.9	31.6	28.2	28.0	21.2
	K.W.	3.0	3.0	3.0	3.1	3.1	3.1	3.1	3.0	3.1	3.1	3.1	3.1	3.0	3.1	3.1
125	T.C.	28.4	28.4	27.2	30.1	33.3	29.2	29.1	27.5	30.5	33.6	29.9	29.8	27.8	30.8	33.9
	S.C.	28.4	28.4	25.0	24.9	19.0	29.2	29.1	26.2	26.0	19.6	29.9	29.8	27.3	27.1	20.3
	K.W.	3.3	3.3	3.3	3.4	3.4	3.4	3.4	3.3	3.4	3.4	3.4	3.4	3.3	3.4	3.4

NOTE: ALL CAPACITIES ARE NET (KBTUH) WITH INDOOR FAN HEAT ALREADY DEDUCTED AT 1250 BTUH/1000 CFM.

Multipliers for determining the performance with other indoor sections.

NOTE: For dry bulb temperatures different than those listed (between 73-87 F), sensible capacity increases by 1060 BTUH per 1000 CFM per degree above the listed temperature and decreases by 1060 BTUH per 1000 CFM per degree below the listed temperature.

NOTE: KW RATING IS FOR OUTDOOR AND INDOOR UNITS.

HIGH CFM

Air Handler	Coil	T.C.	S.C.	KW
AV36	-	0.98	0.97	0.97
AV/SV48	-	1.01	1.04	0.98
MV16C	FC/MC43C	0.97	0.93	0.95
MV16C	FC/MC48C	0.98	0.95	0.96
MV12D	FC/MC48D	0.97	0.91	0.96
MV12D	FC/MC60D	0.97	0.93	0.97

Variable Speed Furnace	Coil	T.C.	S.C.	KW
(F,L)C8V*B16	FC/MC/PC43B	0.98	0.95	1.00
(F,L)C8V*C16	FC/MC/PC43C	0.98	0.96	1.01
(F,L)C8V*C20	FC/MC/PC43C	0.98	0.95	1.01
FC9(C,V)*B12	FC/MC/PC43B	0.97	0.94	0.97
FC9(C,V)*C16	FC/MC/PC43C	0.97	0.95	1.00
FC9(C,V)*C20	FC/MC/PC43C	0.98	0.95	1.00
(F,L)C8V*C16	FC/MC/PC48C	0.99	0.96	1.02
(F,L)C8V*C20	FC/MC/PC48C	0.98	0.96	1.02
FC9(C,V)*C16	FC/MC/PC48C	0.98	0.96	1.01
FC9(C,V)*C20	FC/MC/PC48C	0.98	0.96	1.12
FC9(C,V)*D20	FC/MC/PC48D	0.99	0.97	1.01
(F,L)C8V*C16	FC/PC60C	0.98	0.97	1.01
(F,L)C8V*C20	FC/PC60C	0.98	0.97	1.01
FC9(C,V)*C16	FC/PC60C	0.97	0.96	1.00
FC9(C,V)*C20	FC/PC60C	0.97	0.96	0.99
FC9(C,V)*D20	FC/MC/PC60D	0.98	0.97	1.00
(F,L)C8V*C20	FC/MC62D	0.99	0.98	1.03
FC9(C,V)*C20	FC/MC62D	0.99	0.98	1.01
FC9(C,V)*D20	FC/MC62D	1.00	0.98	1.02
(F,L)C8V*C16	HC42	0.98	0.95	1.01
(F,L)C8V*C20	HC42	0.97	0.94	1.01
FC9(C,V)*C16	HC42	0.98	0.95	1.00

Continued on Page 39.

Variable Speed Furnace	Coil	T.C.	S.C.	KW
FC9(C,V)*C20	HC42	0.98	0.95	1.00
C*(8,L)C*B12	FC/MC/PC35B	0.95	0.93	1.06
C*(8,L)C*C16	FC/MC/PC35C	0.96	0.95	1.03
C*(8,L)C*C20	FC/MC/PC35C	0.96	0.93	1.01
C*9C*B12	FC/MC/PC35B	0.96	0.94	1.06
C*9C*C16	FC/MC/PC35C	0.96	0.94	1.03
C*9C*C20	FC/MC/PC35C	0.96	0.97	1.06
C*(8,L)C*A12	FC/MC/PC36A	0.94	0.90	1.06
C*(8,L)C*B12	FC/MC/PC36B	0.95	0.92	1.04
C*(8,L)C*C16	FC/MC/PC36C	0.95	0.91	1.02
C*(8,L)C*C20	FC/MC/PC36C	0.95	0.91	1.01
C*9C*B12	FC/MC/PC36B	0.94	0.90	1.04
C*9C*C16	FC/MC/PC36C	0.95	0.91	1.02
C*9C*C20	FC/MC/PC36C	0.96	0.95	1.05
C*(8,L)C*A12	FC/MC/PC37A	0.94	0.86	1.02
C*(8,L)C*B12	FC/MC/PC42B	0.96	0.93	1.02
C*(8,L)C*C16	FC/MC/PC42C	0.97	0.95	1.00
C*(8,L)C*C20	FC/MC/PC42C	0.97	0.94	1.00
C*9C*B12	FC/MC/PC42B	0.96	0.93	1.06
C*9C*C16	FC/MC/PC42C	0.96	0.93	1.02
C*9C*C20	FC/MC/PC42C	0.98	0.98	1.04
C*(8,L)C*B12	FC/MC/PC43B	0.96	0.95	1.06
C*(8,L)C*C16	FC/MC/PC43C	0.98	0.96	1.02
C*(8,L)C*C20	FC/MC/PC43C	0.98	0.96	1.01
C*9C*B12	FC/MC/PC43B	0.96	0.94	1.06
C*9C*C16	FC/MC/PC43C	0.97	0.96	1.05
C*9C*C20	FC/MC/PC43C	0.97	0.95	1.02
C*(8,L)C*C16	FC/MC/PC48C	0.97	0.96	1.00
C*(8,L)C*C20	FC/MC/PC48C	0.97	0.94	0.99
C*9C*C16	FC/MC/PC48C	0.96	0.95	1.02
C*9C*C20	FC/MC/PC48C	0.97	0.99	1.05
C*(8,L)C*C16	FC/PC60C	0.97	0.96	1.00
C*(8,L)C*C20	FC/PC60C	0.97	0.97	1.00
C*9C*C16	FC/PC60C	0.96	0.97	1.03
C*9C*C20	FC/PC60C	0.97	1.00	1.04
C*9C*D20	FC/MC/PC60D	0.96	0.97	1.01
C*9C*D20	FC/MC62D	0.99	0.99	1.02
C*(8,L)C*C16	HC42	0.97	0.96	1.02
C*(8,L)C*C20	HC42	0.97	0.95	1.01
C*9C*C16	HC42	0.97	0.95	1.04
C*9C*C20	HC42	0.97	0.96	1.02
C*(8,L)C*B12	HD48	0.96	0.94	1.04
C*(8,L)C*C16	HD48	0.97	0.95	1.01
C*(8,L)C*C20	HD48	0.96	0.93	1.00
C*9C*B12	HD48	0.94	0.91	1.04
C*9C*C16	HD48	0.96	0.95	1.02
C*9C*C20	HD48	1.00	0.99	1.05
C*(8,L)C*A12	UC36A	0.94	0.90	1.06
C*(8,L)C*B12	UC36B	0.94	0.91	1.04
C*(8,L)C*C16	UC36C	0.95	0.91	1.02
C*(8,L)C*C20	UC36C	0.95	0.91	1.01
C*9C*B12	UC36B	0.94	0.90	1.04
C*9C*C16	UC36C	0.95	0.91	1.02

Variable Speed Furnace	Coil	T.C.	S.C.	KW
C*9C*C20	UC36C	0.96	0.95	1.05
C*(8,L)C*B12	UC42B	0.95	0.91	1.02
C*(8,L)C*C16	UC42C	0.96	0.93	1.00
C*(8,L)C*C20	UC42C	0.96	0.92	0.99
C*9C*B12	UC42B	0.95	0.92	1.06
C*9C*C16	UC42C	0.95	0.91	1.02
C*9C*C20	UC42C	0.96	0.96	1.04
C*(8,L)C*C16	UC48C	0.97	0.97	1.01
C*(8,L)C*C20	UC48C	0.97	0.95	1.00
C*9C*C16	UC48C	0.97	0.96	1.02
C*9C*C20	UC48C	0.99	1.01	1.06
C*(8,L)C*C16	UC60C	0.97	0.95	1.00
C*(8,L)C*C20	UC60C	0.97	0.95	1.01
C*9C*C16	UC60C	0.97	0.94	1.04
C*9C*C20	UC60C	0.98	0.99	1.05
C*9C*D20	UC60D	0.97	0.95	1.02
G*9V*B12	FC/MC/PC35B	0.96	0.94	1.06
G*9V*C16	FC/MC/PC35C	0.96	0.94	1.03
G*9V*C20	FC/MC/PC35C	0.96	0.97	1.06
G*9V*B12	FC/MC/PC36B	0.94	0.90	1.04
G*9V*A12	FC/MC/PC36A	0.94	0.90	1.07
G*9V*C16	FC/MC/PC36C	0.95	0.91	1.02
G*9V*C20	FC/MC/PC36C	0.96	0.95	1.05
G*9V*B12	FC/MC/PC42B	0.96	0.93	1.06
G*9V*C16	FC/MC/PC42C	0.96	0.93	1.02
G*9V*C20	FC/MC/PC42C	0.98	0.98	1.04
G*9V*A12	FC/MC/PC37A	0.95	0.90	1.05
G*9V*B12	FC/MC/PC43B	0.96	0.94	1.06
G*9V*C16	FC/MC/PC43C	0.97	0.96	1.05
G*9V*C20	FC/MC/PC43C	0.97	0.95	1.02
G*9V*C16	FC/MC/PC48C	0.96	0.95	1.02
G*9V*C20	FC/MC/PC48C	0.97	0.99	1.05
G*9V*C16	FC/PC60C	0.96	0.97	1.03
G*9V*C20	FC/PC60C	0.97	1.00	1.04
G*9V*D20	FC/MC/PC60D	0.96	0.97	1.01
G*9V*D20	FC/MC62D	0.99	0.99	1.02
G*9V*C16	HC42	0.97	0.95	1.04
G*9V*C20	HC42	0.97	0.96	1.02
G*9V*B12	HD48	0.94	0.91	1.04
G*9V*C16	HD48	0.96	0.95	1.02
G*9V*C20	HD48	1.00	0.99	1.05
G*9V*A12	UC36A	0.94	0.90	1.06
G*9V*B12	UC36B	0.94	0.90	1.04
G*9V*C16	UC36C	0.95	0.91	1.02
G*9V*C20	UC36C	0.96	0.95	1.05
G*9V*B12	UC42B	0.95	0.92	1.06
G*9V*C16	UC42C	0.95	0.91	1.02
G*9V*C20	UC42C	0.96	0.96	1.04
G*9V*C16	UC48C	0.97	0.96	1.02
G*9V*C20	UC48C	0.99	1.01	1.06
G*9V*C16	UC60C	0.97	0.94	1.04
G*9V*C20	UC60C	0.98	0.99	1.05
G*9V*D20	UC60D	0.97	0.95	1.02

COOLING PERFORMANCE DATA - LOW CFM 1-STAGE OPERATION																
OUTDOOR UNIT MODEL NO.		HC8B048F1														
INDOOR COIL MODEL NO.		FC/MC62D + MV20D														
CONDENSER ENTERING AIR TEMPERATURE	ID CFM	1000					1050					1100				
	ID DB (°F)	80	80	75	80	80	80	80	75	80	80	80	80	75	80	80
	ID WB (°F)	57	62	62	67	72	57	62	62	67	72	57	62	62	67	72
65	T.C.	33.8	35.9	35.8	39.4	43.5	34.4	36.3	36.2	39.9	43.9	35.0	36.8	36.6	40.4	44.4
	S.C.	33.8	31.5	26.6	26.7	22.2	34.4	32.4	27.2	27.4	22.5	35.0	33.3	27.8	28.0	22.8
	K.W.	1.5	1.5	1.5	1.5	1.5	1.5	1.5	1.5	1.5	1.5	1.5	1.5	1.5	1.5	1.5
75	T.C.	32.6	34.2	34.1	37.7	41.5	33.2	34.6	34.5	38.1	42.0	33.7	35.0	34.8	38.5	42.4
	S.C.	32.6	30.8	25.9	26.0	21.3	33.2	31.7	26.5	26.6	21.6	33.7	32.6	27.1	27.3	21.9
	K.W.	1.8	1.8	1.8	1.8	1.8	1.8	1.8	1.8	1.8	1.8	1.8	1.8	1.8	1.8	1.8
85	T.C.	31.4	32.5	32.5	36.0	39.6	31.9	32.9	32.8	36.3	40.0	32.5	33.2	33.1	36.7	40.4
	S.C.	31.4	30.1	25.2	25.3	20.4	31.9	31.0	25.8	25.9	20.7	32.5	31.9	26.4	26.5	21.1
	K.W.	2.1	2.1	2.1	2.0	2.0	2.1	2.1	2.1	2.0	2.0	2.1	2.1	2.1	2.0	2.0
95	T.C.	30.2	30.8	30.8	34.2	37.6	30.7	31.1	31.1	34.6	38.0	31.2	31.5	31.4	34.9	38.4
	S.C.	30.2	29.5	24.5	24.5	19.4	30.7	30.3	25.1	25.1	19.8	31.2	31.2	25.7	25.7	20.2
	K.W.	2.3	2.3	2.3	2.3	2.3	2.3	2.3	2.3	2.3	2.3	2.3	2.3	2.3	2.3	2.3
105	T.C.	28.3	28.7	28.2	31.6	34.9	28.7	29.0	28.4	31.8	35.2	29.2	29.4	28.7	32.1	35.5
	S.C.	28.3	27.8	23.3	23.5	18.4	28.7	28.5	24.0	24.1	18.7	29.2	29.2	24.6	24.7	19.1
	K.W.	2.7	2.7	2.7	2.7	2.7	2.7	2.7	2.7	2.7	2.7	2.7	2.7	2.7	2.7	2.7
115	T.C.	26.4	26.7	25.6	29.0	32.2	26.9	27.0	25.9	29.2	32.4	27.3	27.4	26.1	29.4	32.7
	S.C.	26.4	26.2	22.3	22.4	17.3	26.9	26.7	22.9	23.1	17.7	27.3	27.3	23.5	23.7	18.0
	K.W.	3.1	3.1	3.1	3.0	3.0	3.0	3.0	3.1	3.0	3.0	3.0	3.0	3.1	3.0	3.0
125	T.C.	24.6	24.6	23.0	26.5	29.5	25.0	25.0	23.3	26.6	29.7	25.3	25.3	23.5	26.7	29.8
	S.C.	24.6	24.6	21.2	21.4	16.2	25.0	25.0	21.8	22.0	16.6	25.3	25.3	22.4	22.6	17.0
	K.W.	3.4	3.4	3.4	3.4	3.4	3.4	3.4	3.4	3.4	3.4	3.4	3.4	3.4	3.4	3.4

NOTE: ALL CAPACITIES ARE NET (KBTUH) WITH INDOOR FAN HEAT ALREADY DEDUCTED AT 1250 BTUH/1000 CFM.

Multipliers for determining the performance with other indoor sections.

NOTE: For dry bulb temperatures different than those listed (between 73-87 F), sensible capacity increases by 1060 BTUH per 1000 CFM per degree above the listed temperature and decreases by 1060 BTUH per 1000 CFM per degree below the listed temperature.

NOTE: KW RATING IS FOR OUTDOOR AND INDOOR UNITS.

Continued on Page 41.

LOW CFM

Air Handler	Coil	T.C.	S.C.	KW
AV/SV48	-	1.01	1.02	0.99
AV/SV60	-	0.99	1.01	0.97
MV16C	FC/MC48C	1.01	1.02	0.99
MV20D	FC/MC48D	0.99	0.97	0.96
MV20D	FC/MC60D	0.98	0.97	0.95

Variable Speed Furnace	Coil	T.C.	S.C.	KW
(F,L)C8V*C16	FC/MC/PC48C	0.98	0.91	0.96
(F,L)C8V*C20	FC/MC/PC48C	0.98	0.97	0.96
FC9(C,V)*C16	FC/MC/PC48C	1.01	1.01	1.00
FC9(C,V)*C20	FC/MC/PC48C	0.98	0.95	0.95
FC9(C,V)*D20	FC/MC/PC48D	0.98	0.95	0.96
(F,L)C8V*C16	FC/PC60C	0.95	0.91	0.96
(F,L)C8V*C20	FC/PC60C	0.98	0.98	0.96
FC9(C,V)*C16	FC/PC60C	0.99	1.01	0.99
FC9(C,V)*C20	FC/PC60C	0.98	0.97	0.96
FC9(C,V)*D20	FC/MC/PC60D	0.98	0.95	0.96
(F,L)C8V*C20	FC/MC62D	0.99	0.98	0.98
FC9(C,V)*C20	FC/MC62D	0.98	0.98	0.96
FC9(C,V)*D20	FC/MC62D	0.98	0.96	0.96
C*(8,L)C*C16	FC/MC/PC48C	0.99	0.97	1.02
C*(8,L)C*C20	FC/MC/PC48C	1.00	0.99	1.03
C*9C*C16	FC/MC/PC48C	0.99	0.97	1.03
C*9C*C20	FC/MC/PC48C	0.99	0.98	1.02
C*9C*D20	FC/MC/PC48D	0.99	0.98	1.03
C*(8,L)C*C16	FC/PC60C	0.99	0.98	1.01
C*(8,L)C*C20	FC/PC60C	0.98	0.97	1.00
C*9C*C16	FC/PC60C	0.98	0.98	1.03
C*9C*C20	FC/PC60C	0.99	0.98	1.02
C*9C*D20	FC/MC/PC60D	0.99	0.99	1.03
C*9C*D20	FC/MC62D	0.99	0.99	1.03
C*9C*D20	HC60	0.98	0.99	1.03
C*(8,L)C*C16	HD48	0.98	0.95	1.02
C*(8,L)C*C20	HD48	0.96	0.95	1.03
C*9C*C16	HD48	0.98	0.95	1.03

Variable Speed Furnace	Coil	T.C.	S.C.	KW
C*9C*C20	HD48	0.98	0.95	1.02
C*9C*D20	HD48	0.95	0.94	1.03
C*(8,L)C*C16	HD60	0.99	0.96	1.01
C*(8,L)C*C20	HD60	0.99	0.96	1.00
C*9C*C16	HD60	0.99	0.97	1.03
C*9C*C20	HD60	0.99	0.97	1.02
C*9C*D20	HD60	0.99	0.98	1.03
C*(8,L)C*C16	UC48C	0.98	0.97	1.02
C*(8,L)C*C20	UC48C	1.00	0.99	1.03
C*9C*C16	UC48C	0.99	0.98	1.03
C*9C*C20	UC48C	0.98	0.98	1.02
C*9C*D20	UC48D	0.98	0.98	1.03
C*(8,L)C*C16	UC60C	0.98	0.95	1.01
C*(8,L)C*C20	UC60C	0.98	0.95	1.00
C*9C*C16	UC60C	0.98	0.95	1.03
C*9C*C20	UC60C	0.98	0.96	1.02
C*9C*D20	UC60D	0.98	0.96	1.03
G*9V*C16	FC/MC/PC48C	0.99	0.97	1.03
G*9V*C20	FC/MC/PC48C	0.99	0.98	1.02
G*9V*D20	FC/MC/PC48D	0.99	0.98	1.03
G*9V*C16	FC/PC60C	0.98	0.98	1.03
G*9V*C20	FC/PC60C	0.99	0.98	1.02
G*9V*D20	FC/MC/PC60D	0.99	0.99	1.03
G*9V*D20	FC/MC62D	0.99	0.99	1.03
G*9V*D20	HC60	0.98	0.99	1.03
G*9V*C16	HD48	0.98	0.95	1.03
G*9V*C20	HD48	0.98	0.95	1.02
G*9V*D20	HD48	0.95	0.94	1.03
G*9V*C16	HD60	0.99	0.97	1.03
G*9V*C20	HD60	0.99	0.97	1.02
G*9V*D20	HD60	0.99	0.98	1.03
G*9V*C16	UC48C	0.99	0.98	1.03
G*9V*C20	UC48C	0.98	0.98	1.02
G*9V*D20	UC48D	0.98	0.98	1.03
G*9V*C16	UC60C	0.98	0.95	1.03
G*9V*C20	UC60C	0.98	0.96	1.02
G*9V*D20	UC60D	0.98	0.96	1.03

COOLING PERFORMANCE DATA - HIGH CFM 2-STAGE OPERATION																
OUTDOOR UNIT MODEL NO.		HC8B048F1														
INDOOR COIL MODEL NO.		FC/MC62D + MV20D														
CONDENSER ENTERING AIR TEMPERATURE	ID CFM	1470					1570					1670				
	ID DB (°F)	80	80	75	80	80	80	80	75	80	80	80	80	75	80	80
	ID WB (°F)	57	62	62	67	72	57	62	62	67	72	57	62	62	67	72
65	T.C.	47.6	49.8	49.6	54.3	58.9	48.5	50.1	50.2	54.9	59.2	49.5	50.5	50.8	55.5	59.5
	S.C.	47.6	44.6	37.5	37.5	30.0	48.5	46.3	38.7	38.5	30.5	49.5	48.0	39.8	39.6	31.0
	K.W.	2.3	2.3	2.3	2.4	2.5	2.3	2.3	2.3	2.4	2.5	2.3	2.4	2.4	2.4	2.5
75	T.C.	45.9	47.5	47.5	51.8	56.3	46.8	47.9	48.0	52.4	56.7	47.7	48.2	48.5	52.9	57.0
	S.C.	45.9	43.6	36.5	36.4	28.9	46.8	45.1	37.6	37.5	29.5	47.7	46.6	38.7	38.5	30.0
	K.W.	2.7	2.7	2.7	2.7	2.8	2.7	2.7	2.7	2.7	2.8	2.7	2.7	2.7	2.7	2.8
85	T.C.	44.3	45.3	45.4	49.4	53.8	45.1	45.7	45.7	49.8	54.2	46.0	46.0	46.1	50.3	54.6
	S.C.	44.3	42.7	35.5	35.4	27.9	45.1	43.9	36.6	36.4	28.5	46.0	45.2	37.7	37.4	29.0
	K.W.	3.0	3.0	3.0	3.1	3.1	3.0	3.0	3.0	3.1	3.1	3.0	3.0	3.0	3.1	3.1
95	T.C.	42.6	43.0	43.3	47.0	51.2	43.4	43.4	43.5	47.3	51.7	44.2	43.8	43.7	47.7	52.2
	S.C.	42.6	41.7	34.5	34.3	26.8	43.4	42.8	35.6	35.3	27.4	44.2	43.8	36.6	36.3	28.0
	K.W.	3.3	3.3	3.3	3.4	3.5	3.3	3.3	3.3	3.4	3.5	3.3	3.3	3.3	3.4	3.5
105	T.C.	40.1	40.4	40.0	43.6	47.5	40.8	40.8	40.2	43.9	47.9	41.5	41.2	40.5	44.2	48.3
	S.C.	40.1	39.6	33.1	32.9	25.3	40.8	40.4	34.1	33.9	25.9	41.5	41.2	35.2	34.9	26.5
	K.W.	3.8	3.8	3.7	3.8	3.9	3.8	3.8	3.8	3.8	3.9	3.8	3.8	3.8	3.8	3.9
115	T.C.	37.7	37.9	36.8	40.4	44.0	38.3	38.3	37.1	40.6	44.3	38.9	38.8	37.3	40.9	44.6
	S.C.	37.7	37.5	31.6	31.4	23.8	38.3	38.1	32.7	32.5	24.4	38.9	38.8	33.8	33.6	25.1
	K.W.	4.2	4.2	4.1	4.2	4.3	4.2	4.2	4.2	4.2	4.3	4.2	4.2	4.2	4.2	4.3
125	T.C.	35.3	35.3	33.7	37.1	40.4	35.8	35.8	33.9	37.3	40.6	36.3	36.3	34.2	37.5	40.8
	S.C.	35.3	35.3	30.2	30.0	22.3	35.8	35.8	31.3	31.1	22.9	36.3	36.3	32.5	32.2	23.6
	K.W.	4.6	4.6	4.6	4.6	4.7	4.6	4.6	4.6	4.6	4.7	4.6	4.6	4.6	4.6	4.7

NOTE: ALL CAPACITIES ARE NET (KBTUH) WITH INDOOR FAN HEAT ALREADY DEDUCTED AT 1250 BTUH/1000 CFM.

Multipliers for determining the performance with other indoor sections.

NOTE: For dry bulb temperatures different than those listed (between 73-87 F), sensible capacity increases by 1060 BTUH per 1000 CFM per degree above the listed temperature and decreases by 1060 BTUH per 1000 CFM per degree below the listed temperature.

NOTE: KW RATING IS FOR OUTDOOR AND INDOOR UNITS.

Continued on Page 43.

HIGH CFM

Air Handler	Coil	T.C.	S.C.	KW
AV/SV48	–	1.00	1.00	0.98
AV/SV60	–	1.01	1.01	0.98
MV16C	FC/MC48C	1.00	1.00	0.98
MV20D	FC/MC48D	0.99	0.97	0.96
MV20D	FC/MC60D	1.00	1.00	0.98

Variable Speed Furnace	Coil	T.C.	S.C.	KW
(F,L)C8V*C16	FC/MC/PC48C	0.98	0.91	0.96
(F,L)C8V*C20	FC/MC/PC48C	0.98	0.97	0.96
FC9(C,V)*C16	FC/MC/PC48C	1.01	1.01	1.00
FC9(C,V)*C20	FC/MC/PC48C	0.98	0.95	0.95
FC9(C,V)*D20	FC/MC/PC48D	0.98	0.95	0.96
(F,L)C8V*C16	FC/PC60C	0.95	0.91	0.96
(F,L)C8V*C20	FC/PC60C	0.98	0.98	0.96
FC9(C,V)*C16	FC/PC60C	0.99	1.01	0.99
FC9(C,V)*C20	FC/PC60C	0.98	0.97	0.96
FC9(C,V)*D20	FC/MC/PC60D	0.98	0.95	0.96
(F,L)C8V*C20	FC/MC62D	0.99	0.98	0.98
FC9(C,V)*C20	FC/MC62D	0.98	0.98	0.96
FC9(C,V)*D20	FC/MC62D	0.98	0.96	0.96
C*(8,L)C*C16	FC/MC/PC48C	0.99	0.97	1.05
C*(8,L)C*C20	FC/MC/PC48C	0.99	0.97	1.05
C*9C*C16	FC/MC/PC48C	0.98	0.96	1.05
C*9C*C20	FC/MC/PC48C	0.98	0.96	1.05
C*9C*D20	FC/MC/PC48D	0.99	0.97	1.05
C*(8,L)C*C16	FC/PC60C	1.00	0.99	1.04
C*(8,L)C*C20	FC/PC60C	1.00	0.99	1.02
C*9C*C16	FC/PC60C	0.99	0.98	1.05
C*9C*C20	FC/PC60C	0.99	0.98	1.05
C*9C*D20	FC/MC/PC60D	0.98	0.98	1.04
C*9C*D20	FC/MC62D	0.99	0.99	1.05
C*9C*D20	HC60	0.99	0.98	1.05
C*(8,L)C*C16	HD48	0.97	0.95	1.05
C*(8,L)C*C20	HD48	0.97	0.95	1.05
C*9C*C16	HD48	0.97	0.94	1.05

Variable Speed Furnace	Coil	T.C.	S.C.	KW
C*9C*C20	HD48	0.97	0.94	1.05
C*9C*D20	HD48	0.97	0.95	1.05
C*(8,L)C*C16	HD60	0.98	0.98	1.04
C*(8,L)C*C20	HD60	0.99	0.99	1.02
C*9C*C16	HD60	0.98	0.98	1.05
C*9C*C20	HD60	0.98	0.98	1.05
C*9C*D20	HD60	0.98	0.98	1.05
C*(8,L)C*C16	UC48C	0.99	0.97	1.05
C*(8,L)C*C20	UC48C	0.99	0.97	1.05
C*9C*C16	UC48C	0.99	0.97	1.05
C*9C*C20	UC48C	0.99	0.97	1.05
C*9C*D20	UC48D	0.99	0.97	1.05
C*(8,L)C*C16	UC60C	0.98	0.96	1.04
C*(8,L)C*C20	UC60C	0.99	0.97	1.02
C*9C*C16	UC60C	0.98	0.96	1.05
C*9C*C20	UC60C	0.98	0.96	1.05
C*9C*D20	UC60D	0.98	0.96	1.04
G*9V*C16	FC/MC/PC48C	0.98	0.96	1.05
G*9V*C20	FC/MC/PC48C	0.98	0.96	1.05
G*9V*D20	FC/MC/PC48D	0.99	0.97	1.05
G*9V*C16	FC/PC60C	0.99	0.98	1.05
G*9V*C20	FC/PC60C	0.99	0.98	1.05
G*9V*D20	FC/MC/PC60D	0.98	0.98	1.04
G*9V*D20	FC/MC62D	0.99	0.99	1.05
G*9V*D20	HC60	0.99	0.98	1.05
G*9V*C16	HD48	0.97	0.94	1.05
G*9V*C20	HD48	0.97	0.94	1.05
G*9V*D20	HD48	0.97	0.95	1.05
G*9V*C16	HD60	0.98	0.98	1.05
G*9V*C20	HD60	0.98	0.98	1.05
G*9V*D20	HD60	0.98	0.98	1.05
G*9V*C16	UC48C	0.99	0.97	1.05
G*9V*C20	UC48C	0.99	0.97	1.05
G*9V*D20	UC48D	0.99	0.97	1.05
G*9V*C16	UC60C	0.98	0.96	1.05
G*9V*C20	UC60C	0.98	0.96	1.05
G*9V*D20	UC60D	0.98	0.96	1.04

COOLING PERFORMANCE DATA - LOW CFM 1-STAGE OPERATION																
OUTDOOR UNIT MODEL NO.		HC8B060F1														
INDOOR COIL MODEL NO.		FC/MC62D + MV20D														
CONDENSER ENTERING AIR TEMPERATURE	ID CFM	1125					1175					1225				
	ID DB (°F)	80	80	75	80	80	80	80	75	80	80	80	80	75	80	80
	ID WB (°F)	57	62	62	67	72	57	62	62	67	72	57	62	62	67	72
65	T.C.	40.8	44.0	43.6	48.6	53.8	41.5	44.4	44.1	49.2	54.3	42.3	44.8	44.7	49.8	54.9
	S.C.	40.8	37.2	31.3	31.5	25.9	41.5	38.0	32.0	32.1	26.3	42.3	38.9	32.6	32.7	26.8
	K.W.	2.0	2.0	2.0	2.0	2.0	2.0	2.0	2.0	2.0	2.0	2.0	2.0	2.0	2.0	2.0
75	T.C.	39.3	42.0	41.7	46.5	51.4	40.0	42.4	42.2	47.0	51.9	40.8	42.8	42.7	47.5	52.5
	S.C.	39.3	36.4	30.5	30.6	24.9	40.0	37.3	31.2	31.2	25.3	40.8	38.2	31.8	31.8	25.7
	K.W.	2.3	2.3	2.3	2.3	2.3	2.3	2.3	2.3	2.3	2.3	2.3	2.3	2.3	2.3	2.3
85	T.C.	37.9	39.9	39.7	44.3	49.1	38.5	40.4	40.2	44.8	49.6	39.2	40.8	40.8	45.3	50.0
	S.C.	37.9	35.6	29.7	29.8	23.8	38.5	36.6	30.4	30.4	24.3	39.2	37.5	31.1	31.0	24.7
	K.W.	2.7	2.7	2.7	2.7	2.7	2.7	2.7	2.7	2.7	2.7	2.7	2.7	2.7	2.7	2.7
95	T.C.	36.4	37.9	37.8	42.2	46.7	37.0	38.4	38.3	42.6	47.2	37.6	38.9	38.8	43.0	47.6
	S.C.	36.4	34.9	28.9	28.9	22.8	37.0	35.8	29.6	29.5	23.2	37.6	36.8	30.4	30.2	23.7
	K.W.	3.1	3.0	3.1	3.0	3.0	3.1	3.0	3.0	3.0	3.0	3.1	3.0	3.0	3.0	3.0
105	T.C.	34.4	35.1	35.0	39.0	43.7	34.9	35.7	35.4	39.5	44.1	35.4	36.3	35.9	39.9	44.5
	S.C.	34.4	33.1	27.8	27.7	21.6	34.9	34.0	28.5	28.3	22.1	35.4	34.9	29.2	29.0	22.5
	K.W.	3.5	3.5	3.5	3.5	3.5	3.5	3.5	3.5	3.5	3.5	3.5	3.5	3.5	3.5	3.5
115	T.C.	32.4	32.3	32.3	36.0	40.7	32.8	33.1	32.7	36.4	41.1	33.3	33.8	33.0	36.8	41.4
	S.C.	32.4	31.3	26.7	26.5	20.5	32.8	32.2	27.4	27.2	20.9	33.3	33.1	28.0	27.8	21.3
	K.W.	4.0	4.0	4.0	4.0	4.0	4.0	4.0	4.0	4.0	4.0	4.0	4.0	4.0	4.0	4.0
125	T.C.	30.4	29.6	29.6	33.0	37.7	30.7	30.4	29.9	33.4	38.0	31.1	31.3	30.2	33.8	38.4
	S.C.	30.4	29.6	25.5	25.4	19.4	30.7	30.4	26.2	26.0	19.8	31.1	31.3	26.9	26.7	20.2
	K.W.	4.5	4.5	4.5	4.4	4.4	4.5	4.5	4.5	4.4	4.4	4.5	4.5	4.5	4.4	4.4

NOTE: ALL CAPACITIES ARE NET (KBTUH) WITH INDOOR FAN HEAT ALREADY DEDUCTED AT 1250 BTUH/1000 CFM.

Multipliers for determining the performance with other indoor sections.

NOTE: For dry bulb temperatures different than those listed (between 73-87 F), sensible capacity increases by 1060 BTUH per 1000 CFM per degree above the listed temperature and decreases by 1060 BTUH per 1000 CFM per degree below the listed temperature.

NOTE: KW RATING IS FOR OUTDOOR AND INDOOR UNITS.

LOW CFM

Air Handler	Coil	T.C.	S.C.	KW
AV/SV60	-	0.99	0.97	0.98
MV20D	FC/MC60D	0.96	0.87	1.09

Variable Speed Furnace	Coil	T.C.	S.C.	KW
(F,L)C8V*C20	FC/PC60C	0.98	0.96	0.96
FC9(C,V)*C20	FC/PC60C	0.96	0.94	0.95
FC9(C,V)*D20	FC/MC/PC60D	0.95	0.92	0.95
(F,L)C8V*C20	FC/MC62D	0.98	0.97	0.97
FC9(C,V)*C20	FC/MC62D	0.98	0.95	0.96
FC9(C,V)*D20	FC/MC62D	0.96	0.93	0.95
C*(8,L)*C20	FC/PC60C	0.98	0.93	1.00
C*9C*C20	FC/PC60C	0.98	0.95	1.01
C*(8,L)*C20	FC/MC/PC60D	0.97	0.93	1.00
C*9C*C20	FC/MC/PC60D	0.97	0.93	1.01
C*9C*D20	FC/MC/PC60D	0.99	0.95	1.01
C*(8,L)*C20	FC/MC62D	0.97	0.94	1.00
C*9C*C20	FC/MC62D	0.97	0.94	1.01

Variable Speed Furnace	Coil	T.C.	S.C.	KW
C*9C*D20	FC/MC62D	0.98	0.96	1.01
C*9C*D20	HC60	0.98	0.95	1.01
C*(8,L)*C20	HD60	0.96	0.92	0.99
C*9C*C20	HD60	0.96	0.93	1.00
C*9C*D20	HD60	0.97	0.94	1.01
C*(8,L)*C20	UC60C	0.96	0.91	1.00
C*9C*C20	UC60C	0.96	0.93	1.01
C*9C*D20	UC60D	0.96	0.93	1.02
G*9V*C20	FC/PC60C	0.98	0.95	1.01
G*9V*C20	FC/MC/PC60D	0.97	0.93	1.01
G*9V*D20	FC/MC/PC60D	0.99	0.95	1.01
G*9V*C20	FC/MC62D	0.97	0.94	1.01
G*9V*D20	FC/MC62D	0.98	0.96	1.01
G*9V*D20	HC60	0.98	0.95	1.01
G*9V*C20	HD60	0.96	0.93	1.00
G*9V*D20	HD60	0.97	0.94	1.01
G*9V*C20	UC60C	0.96	0.93	1.01
G*9V*D20	UC60D	0.96	0.93	1.02

COOLING PERFORMANCE DATA - HIGH CFM 2-STAGE OPERATION																
OUTDOOR UNIT MODEL NO.		HC8B060F1														
INDOOR COIL MODEL NO.		FC/MC62D + MV20D														
CONDENSER ENTERING AIR TEMPERATURE	ID CFM	1718					1818					1918				
	ID DB (°F)	80	80	75	80	80	80	80	75	80	80	80	80	75	80	80
	ID WB (°F)	57	62	62	67	72	57	62	62	67	72	57	62	62	67	72
65	T.C.	57.5	60.6	60.7	65.4	73.0	58.5	61.3	61.4	66.1	73.4	59.5	62.0	62.0	66.8	73.8
	S.C.	57.5	53.3	45.1	44.5	37.1	58.5	54.8	46.3	45.7	37.5	59.5	56.4	47.5	46.9	38.0
	K.W.	2.8	2.9	2.9	3.0	3.1	2.8	2.9	2.9	3.0	3.1	2.9	2.9	2.9	3.0	3.1
75	T.C.	55.5	57.9	58.0	62.8	69.7	56.5	58.6	58.6	63.5	70.1	57.4	59.2	59.2	64.1	70.5
	S.C.	55.5	52.1	43.9	43.4	35.5	56.5	53.6	45.0	44.5	36.0	57.4	55.2	46.2	45.7	36.6
	K.W.	3.3	3.4	3.4	3.5	3.6	3.3	3.4	3.4	3.5	3.6	3.4	3.4	3.4	3.5	3.6
85	T.C.	53.5	55.2	55.3	60.3	66.4	54.4	55.8	55.9	60.8	66.8	55.3	56.4	56.5	61.4	67.2
	S.C.	53.5	50.8	42.6	42.3	33.9	54.4	52.4	43.7	43.3	34.5	55.3	53.9	44.9	44.4	35.1
	K.W.	3.8	3.8	3.8	4.0	4.1	3.8	3.8	3.9	4.0	4.1	3.8	3.9	3.9	4.0	4.1
95	T.C.	51.5	52.6	52.6	57.7	63.1	52.4	53.1	53.2	58.2	63.5	53.3	53.6	53.7	58.7	63.9
	S.C.	51.5	49.6	41.4	41.1	32.4	52.4	51.2	42.5	42.2	33.0	53.3	52.7	43.6	43.2	33.6
	K.W.	4.3	4.3	4.3	4.4	4.6	4.3	4.3	4.3	4.5	4.6	4.3	4.3	4.3	4.5	4.6
105	T.C.	48.8	49.1	49.2	54.0	59.4	49.6	49.9	49.7	54.4	59.8	50.4	50.7	50.1	54.7	60.2
	S.C.	48.8	47.2	39.8	39.5	30.8	49.6	48.6	40.9	40.5	31.5	50.4	50.1	42.0	41.6	32.1
	K.W.	4.9	4.9	4.9	5.0	5.1	4.9	4.9	4.9	5.0	5.1	4.9	4.9	4.9	5.0	5.1
115	T.C.	46.3	45.8	45.9	50.4	55.8	47.0	46.8	46.3	50.6	56.2	47.7	47.8	46.7	50.9	56.5
	S.C.	46.3	44.9	38.2	37.9	29.4	47.0	46.2	39.3	38.9	30.0	47.7	47.5	40.4	40.0	30.6
	K.W.	5.4	5.4	5.4	5.5	5.6	5.5	5.5	5.5	5.5	5.6	5.5	5.5	5.5	5.5	5.6
125	T.C.	43.7	42.5	42.6	46.8	52.2	44.3	43.7	42.9	46.9	52.5	44.9	44.9	43.2	47.1	52.9
	S.C.	43.7	42.5	36.7	36.3	27.9	44.3	43.7	37.8	37.3	28.5	44.9	44.9	38.8	38.4	29.1
	K.W.	6.0	6.0	6.0	6.1	6.1	6.0	6.0	6.0	6.1	6.1	6.1	6.1	6.0	6.1	6.2

NOTE: ALL CAPACITIES ARE NET (KBTUH) WITH INDOOR FAN HEAT ALREADY DEDUCTED AT 1250 BTUH/1000 CFM.

Multipliers for determining the performance with other indoor sections.

NOTE: For dry bulb temperatures different than those listed (between 73-87 F), sensible capacity increases by 1060 BTUH per 1000 CFM per degree above the listed temperature and decreases by 1060 BTUH per 1000 CFM per degree below the listed temperature.

NOTE: KW RATING IS FOR OUTDOOR AND INDOOR UNITS.

HIGH CFM

Air Handler	Coil	T.C.	S.C.	KW
AV/SV60C	-	0.99	0.97	0.97
MV20DC	FC/MC60D	1.00	0.60	1.18

Variable Speed Furnace	Coil	T.C.	S.C.	KW
(F,L)C8V*C20	FC/PC60C	0.98	0.96	0.96
FC9(C,V)*C20	FC/PC60C	0.96	0.94	0.95
FC9(C,V)*D20	FC/MC/PC60D	0.95	0.92	0.95
(F,L)C8V*C20	FC/MC62D	0.98	0.97	0.97
FC9(C,V)*C20	FC/MC62D	0.98	0.95	0.96
FC9(C,V)*D20	FC/MC62D	0.96	0.93	0.95
C*(8,L)C*C20	FC/PC60C	0.97	0.93	0.99
C*9C*C20	FC/PC60C	0.97	0.93	1.01
C*(8,L)C*C20	FC/MC/PC60D	0.97	0.93	0.99
C*9C*C20	FC/MC/PC60D	0.96	0.93	1.01
C*9C*D20	FC/MC/PC60D	0.97	0.93	1.01
C*(8,L)C*C20	FC/MC62D	0.98	0.95	0.99
C*9C*C20	FC/MC62D	0.98	0.94	1.02

Variable Speed Furnace	Coil	T.C.	S.C.	KW
C*9C*D20	FC/MC62D	0.98	0.94	1.01
C*9C*D20	HC60	0.97	0.93	1.01
C*(8,L)C*C20	HD60	0.97	0.93	0.99
C*9C*C20	HD60	0.96	0.94	1.01
C*9C*D20	HD60	0.97	0.93	1.00
C*(8,L)C*C20	UC60C	0.96	0.91	0.99
C*9C*C20	UC60C	0.95	0.91	1.01
C*9C*D20	UC60D	0.96	0.91	1.00
G*9V*C20	FC/PC60C	0.97	0.93	1.01
G*9V*C20	FC/MC/PC60D	0.96	0.93	1.01
G*9V*D20	FC/MC/PC60D	0.97	0.93	1.01
G*9V*C20	FC/MC62D	0.98	0.94	1.02
G*9V*D20	FC/MC62D	0.98	0.94	1.01
G*9V*D20	HC60	0.97	0.93	1.01
G*9V*C20	HD60	0.96	0.94	1.01
G*9V*D20	HD60	0.97	0.93	1.00
G*9V*C20	UC60C	0.95	0.91	1.01
G*9V*D20	UC60D	0.96	0.91	1.00

HEATING PERFORMANCE DATA - LOW CFM 1-STAGE OPERATION										
OUTDOOR UNIT MODEL NO.		HC8B024F1								
INDOOR COIL MODEL NO.		FC/MC/PC48D + MV12D								
AIR TEMP. ENTERING OUTDOOR UNIT	AIR TEMP. ENTERING INDOOR COIL	ID CFM								
		600			650			700		
		MBTUH	KW	C.O.P.	MBTUH	KW	C.O.P.	MBTUH	KW	C.O.P.
60	60	24.2	1.4	5.2	24.4	1.3	5.4	24.5	1.3	5.6
	70	23.9	1.5	4.6	24.0	1.5	4.7	24.1	1.4	4.9
	80	23.5	1.7	4.1	23.5	1.6	4.2	23.6	1.6	4.3
47	60	19.8	1.3	4.5	19.8	1.2	4.6	19.8	1.2	4.8
	70	19.3	1.4	4.0	19.3	1.4	4.1	19.4	1.4	4.2
	80	18.8	1.6	3.6	18.9	1.5	3.6	19.0	1.5	3.7
40	60	17.1	1.2	4.1	17.1	1.2	4.2	17.1	1.2	4.3
	70	16.9	1.4	3.7	16.9	1.3	3.7	17.0	1.3	3.8
	80	16.7	1.5	3.3	16.7	1.5	3.3	16.8	1.4	3.4
30	60	13.9	1.2	3.5	14.0	1.1	3.6	14.1	1.1	3.7
	70	14.0	1.3	3.1	14.0	1.3	3.2	14.0	1.3	3.3
	80	14.0	1.4	2.8	13.9	1.4	2.9	13.9	1.4	2.9
17	60	10.5	1.1	2.8	10.9	1.1	2.9	11.4	1.1	3.0
	70	10.4	1.2	2.5	10.6	1.2	2.5	10.8	1.2	2.6
	80	10.3	1.4	2.2	10.3	1.3	2.2	10.3	1.3	2.3
10	60	9.0	1.1	2.3	9.0	1.1	2.4	9.0	1.1	2.4
	70	8.5	1.2	2.1	8.5	1.2	2.1	8.6	1.2	2.2
	80	8.0	1.2	1.9	8.1	1.2	1.9	8.2	1.2	2.0

NOTE: ALL CAPACITIES INCLUDE INDOOR FAN HEAT AT 1250 BTUH/1000 CFM.

Multipliers for determining the performance with other indoor section.

NOTE: KW RATING IS FOR OUTDOOR AND INDOOR UNITS.

LOW CFM

Air Handler	Coil	MBH	KW	COP
AV36	-	1.00	1.00	1.00
MV12B	FC/MC43B	1.00	1.00	1.00
MV12D	FC/MC60D	1.00	1.00	1.00

Variable Speed Furnace	Coil	MBH	KW	COP
FC9(C,V)*B12	FC/MC/PC43B	0.98	0.98	1.02
C*(8,L)C*A12	FC/MC/PC30A	1.00	0.94	0.99
C*(8,L)C*B12	FC/MC/PC30B	0.99	0.95	0.98
C*9C*B12	FC/MC/PC30B	1.00	0.94	0.99
C*(8,L)C*A12	FC/MC/PC32A	1.00	0.93	1.00
C*(8,L)C*B12	FC/MC/PC35B	0.99	0.93	0.99
C*9C*B12	FC/MC/PC35B	1.00	0.94	0.99
C*(8,L)C*A12	FC/MC/PC36A	1.00	0.95	0.98
C*(8,L)C*B12	FC/MC/PC36B	0.99	0.95	0.98
C*9C*B12	FC/MC/PC36B	1.00	0.96	0.98
C*(8,L)C*A12	FC/MC/PC37A	1.01	0.96	0.97
C*(8,L)C*B12	FC/MC/PC43B	1.00	0.96	0.97
C*9C*B12	FC/MC/PC43B	1.00	0.97	0.97
C*(8,L)C*A12	HC30	0.99	0.91	1.01
C*(8,L)C*A12	HD36	0.97	0.78	1.16
C*(8,L)C*B12	HD36	0.96	0.75	1.19

Variable Speed Furnace	Coil	MBH	KW	COP
C*9C*B12	HD36	0.97	0.78	1.16
C*(8,L)C*A12	UC30A	1.00	0.95	0.98
C*(8,L)C*B12	UC30B	1.00	0.96	0.97
C*9C*B12	UC30B	1.00	0.95	0.98
C*(8,L)C*A12	UC36A	1.00	0.95	0.98
C*(8,L)C*B12	UC36B	0.99	0.93	1.00
C*9C*B12	UC36B	1.00	0.95	0.98
G*9V*A12	FC/MC/PC30A	1.00	0.93	1.01
G*9V*B12	FC/MC/PC30B	1.00	0.94	0.99
G*9V*A12	FC/MC/PC32A	1.00	0.92	1.02
G*9V*B12	FC/MC/PC35B	1.00	0.94	0.99
G*9V*A12	FC/MC/PC36A	1.00	0.94	0.99
G*9V*B12	FC/MC/PC36B	1.00	0.96	0.98
G*9V*A12	FC/MC/PC37A	1.01	0.95	0.98
G*9V*B12	FC/MC/PC43B	1.00	0.97	0.97
G*9V*A12	HC30	1.00	0.91	1.02
G*9V*A12	HD36	0.97	0.76	1.19
G*9V*B12	HD36	0.97	0.78	1.16
G*9V*A12	UC30A	1.00	0.94	1.00
G*9V*B12	UC30B	1.00	0.95	0.98
G*9V*A12	UC36A	1.00	0.92	1.01
G*9V*B12	UC36B	1.00	0.95	0.98

HEATING PERFORMANCE DATA - HIGH CFM 2-STAGE OPERATION										
OUTDOOR UNIT MODEL NO.		HC8B024F1								
INDOOR COIL MODEL NO.		FC/MC/PC48D + MV12D								
AIR TEMP. ENTERING OUTDOOR UNIT	AIR TEMP. ENTERING INDOOR COIL	ID CFM								
		750			850			950		
		MBTUH	KW	C.O.P.	MBTUH	KW	C.O.P.	MBTUH	KW	C.O.P.
60	60	31.6	1.7	5.4	32.0	1.7	5.6	32.4	1.6	5.9
	70	30.9	1.9	4.8	31.4	1.8	5.0	31.9	1.8	5.3
	80	30.2	2.0	4.4	30.7	2.0	4.6	31.3	1.9	4.8
47	60	26.8	1.6	4.8	27.0	1.6	5.0	27.2	1.5	5.2
	70	26.4	1.8	4.3	26.6	1.7	4.5	26.8	1.7	4.7
	80	25.9	1.9	3.9	26.1	1.9	4.1	26.3	1.8	4.2
40	60	24.4	1.6	4.5	24.5	1.5	4.7	24.6	1.5	4.9
	70	23.9	1.7	4.1	24.1	1.7	4.2	24.3	1.6	4.4
	80	23.5	1.9	3.7	23.7	1.8	3.8	23.9	1.8	3.9
30	60	20.7	1.5	4.1	20.9	1.5	4.2	21.0	1.4	4.3
	70	20.5	1.6	3.7	20.7	1.6	3.8	20.8	1.6	3.9
	80	20.4	1.8	3.3	20.5	1.7	3.4	20.6	1.7	3.5
17	60	16.6	1.4	3.5	16.7	1.4	3.6	16.8	1.3	3.7
	70	16.6	1.5	3.2	16.6	1.5	3.3	16.7	1.5	3.3
	80	16.5	1.7	2.9	16.6	1.6	3.0	16.6	1.6	3.0
10	60	14.8	1.3	3.2	14.8	1.3	3.3	14.8	1.3	3.4
	70	14.7	1.5	2.9	14.7	1.5	3.0	14.8	1.4	3.0
	80	14.6	1.6	2.7	14.7	1.6	2.7	14.8	1.6	2.8

NOTE: ALL CAPACITIES INCLUDE INDOOR FAN HEAT AT 1250 BTUH/1000 CFM.

Multipliers for determining the performance with other indoor section.

NOTE: KW RATING IS FOR OUTDOOR AND INDOOR UNITS.

HIGH CFM

Air Handler	Coil	MBH	KW	COP
AV36	-	1.00	0.99	1.01
MV12B	FC/MC43B	1.00	1.00	1.00
MV12D	FC/MC60D	1.00	1.00	1.00

Variable Speed Furnace	Coil	MBH	KW	COP
FC9(C,V)*B12	FC/MC/PC43B	1.00	0.98	1.02
C*(8,L)C*A12	FC/MC/PC30A	1.00	0.94	0.99
C*(8,L)C*B12	FC/MC/PC30B	0.99	0.95	0.98
C*9C*B12	FC/MC/PC30B	1.00	0.94	0.99
C*(8,L)C*A12	FC/MC/PC32A	1.00	0.93	1.00
C*(8,L)C*B12	FC/MC/PC35B	0.99	0.93	0.99
C*9C*B12	FC/MC/PC35B	1.00	0.94	0.99
C*(8,L)C*A12	FC/MC/PC36A	1.00	0.95	0.98
C*(8,L)C*B12	FC/MC/PC36B	0.99	0.95	0.98
C*9C*B12	FC/MC/PC36B	1.00	0.96	0.98
C*(8,L)C*A12	FC/MC/PC37A	1.01	0.96	0.97
C*(8,L)C*B12	FC/MC/PC43B	1.00	0.96	0.97
C*9C*B12	FC/MC/PC43B	1.00	0.97	0.97
C*(8,L)C*A12	HC30	0.99	0.91	1.01
C*(8,L)C*A12	HD36	0.97	0.78	1.16
C*(8,L)C*B12	HD36	0.96	0.75	1.19

Variable Speed Furnace	Coil	MBH	KW	COP
C*9C*B12	HD36	0.97	0.78	1.16
C*(8,L)C*A12	UC30A	1.00	0.95	0.98
C*(8,L)C*B12	UC30B	1.00	0.96	0.97
C*9C*B12	UC30B	1.00	0.95	0.98
C*(8,L)C*A12	UC36A	1.00	0.95	0.98
C*(8,L)C*B12	UC36B	0.99	0.93	1.00
C*9C*B12	UC36B	1.00	0.95	0.98
G*9V*A12	FC/MC/PC30A	1.00	0.93	1.01
G*9V*B12	FC/MC/PC30B	1.00	0.94	0.99
G*9V*A12	FC/MC/PC32A	1.00	0.92	1.02
G*9V*B12	FC/MC/PC35B	1.00	0.94	0.99
G*9V*A12	FC/MC/PC36A	1.00	0.94	0.99
G*9V*B12	FC/MC/PC36B	1.00	0.96	0.98
G*9V*A12	FC/MC/PC37A	1.01	0.95	0.98
G*9V*B12	FC/MC/PC43B	1.00	0.97	0.97
G*9V*A12	HC30	1.00	0.91	1.02
G*9V*A12	HD36	0.97	0.76	1.19
G*9V*B12	HD36	0.97	0.78	1.16
G*9V*A12	UC30A	1.00	0.94	1.00
G*9V*B12	UC30B	1.00	0.95	0.98
G*9V*A12	UC36A	1.00	0.92	1.01
G*9V*B12	UC36B	1.00	0.95	0.98

HEATING PERFORMANCE DATA - LOW CFM 1-STAGE OPERATION										
OUTDOOR UNIT MODEL NO.		HC8B036F1								
INDOOR COIL MODEL NO.		FC/MC62D + MV12D								
AIR TEMP. ENTERING OUTDOOR UNIT	AIR TEMP. ENTERING INDOOR COIL	ID CFM								
		759			809			859		
		MBTUH	KW	C.O.P.	MBTUH	KW	C.O.P.	MBTUH	KW	C.O.P.
60	60	31.2	1.8	4.9	31.5	1.8	5.1	31.8	1.8	5.3
	70	30.7	2.1	4.2	30.9	2.1	4.4	31.2	2.0	4.5
	80	30.2	2.4	3.7	30.4	2.3	3.8	30.5	2.3	3.9
47	60	23.5	1.7	4.1	23.6	1.6	4.2	23.7	1.6	4.4
	70	23.1	1.9	3.5	23.1	1.9	3.6	23.2	1.8	3.7
	80	22.7	2.2	3.1	22.7	2.1	3.2	22.7	2.0	3.2
40	60	19.4	1.6	3.6	19.5	1.5	3.7	19.6	1.5	3.8
	70	19.2	1.8	3.1	19.3	1.8	3.2	19.4	1.7	3.3
	80	19.0	2.0	2.7	19.1	2.0	2.8	19.1	2.0	2.9
30	60	14.0	1.5	2.8	14.0	1.4	2.9	14.1	1.4	2.9
	70	14.0	1.7	2.4	14.0	1.6	2.5	14.1	1.6	2.6
	80	13.9	1.9	2.2	14.0	1.8	2.2	14.0	1.8	2.3
17	60	7.6	1.3	1.7	7.6	1.3	1.7	7.7	1.3	1.8
	70	7.8	1.5	1.5	8.0	1.5	1.6	8.2	1.5	1.6
	80	8.1	1.7	1.4	8.4	1.7	1.4	8.7	1.7	1.5
10	60	5.3	1.3	1.2	6.0	1.3	1.4	6.7	1.3	1.5
	70	6.5	1.5	1.2	7.0	1.5	1.4	7.5	1.5	1.5
	80	7.6	1.7	1.3	8.0	1.7	1.4	8.3	1.7	1.5

NOTE: ALL CAPACITIES INCLUDE INDOOR FAN HEAT AT 1250 BTUH/1000 CFM.

Multipliers for determining the performance with other indoor sections.

NOTE: KW RATING IS FOR OUTDOOR AND INDOOR UNITS.

LOW CFM

Air Handler	Coil	MBH	KW	COP
AV36	-	1.00	0.98	1.02
AV/SV48	-	1.00	0.97	1.03
MV16C	FC/MC43C	1.00	0.97	1.03
MV16C	FC/MC48C	1.00	0.97	1.03
MV12D	FC/MC48D	1.00	1.00	1.00
MV12D	FC/MC60D	1.00	1.00	1.00

Variable Speed Furnace	Coil	MBH	KW	COP
(F,L)C8V*B16	FC/MC/PC43B	1.00	0.97	1.03
(F,L)C8V*C16	FC/MC/PC43C	0.96	0.96	1.04
(F,L)C8V*C20	FC/MC/PC43C	1.00	0.97	1.03
FC9(C,V)*B12	FC/MC/PC43B	1.00	0.97	1.03
FC9(C,V)*C16	FC/MC/PC43C	1.00	0.97	1.03
FC9(C,V)*C20	FC/MC/PC43C	1.00	0.97	1.03
(F,L)C8V*C16	FC/MC/PC48C	0.96	0.97	1.03
(F,L)C8V*C20	FC/MC/PC48C	1.00	0.98	1.02
FC9(C,V)*C16	FC/MC/PC48C	1.00	0.98	1.02
FC9(C,V)*C20	FC/MC/PC48C	1.00	0.97	1.03
FC9(C,V)*D20	FC/MC/PC48D	1.00	0.97	1.03
(F,L)C8V*C16	FC/PC60C	0.96	0.97	1.03
(F,L)C8V*C20	FC/PC60C	1.00	0.98	1.02
FC9(C,V)*C16	FC/PC60C	1.00	0.98	1.02
FC9(C,V)*C20	FC/PC60C	1.00	0.97	1.03
FC9(C,V)*D20	FC/MC/PC60D	1.00	0.97	1.03
(F,L)C8V*C20	FC/MC62D	1.00	0.98	1.02
FC9(C,V)*C20	FC/MC62D	1.00	0.97	1.03
FC9(C,V)*D20	FC/MC62D	1.00	0.97	1.03
(F,L)C8V*C16	HC42	0.96	0.97	1.03
(F,L)C8V*C20	HC42	1.00	0.98	1.02
FC9(C,V)*C16	HC42	1.00	0.98	1.02
FC9(C,V)*C20	HC42	1.00	0.97	1.03
C*(8,L)C*B12	FC/MC/PC35B	0.99	0.90	1.10
C*(8,L)C*C16	FC/MC/PC35C	1.00	0.93	1.07

Continued on Page 49.

Variable Speed Furnace	Coil	MBH	KW	COP
C*(8,L)C*C20	FC/MC/PC35C	1.02	0.97	1.05
C*9C*B12	FC/MC/PC35B	1.00	0.92	1.09
C*9C*C16	FC/MC/PC35C	1.00	0.93	1.07
C*9C*C20	FC/MC/PC35C	0.99	0.91	1.09
C*(8,L)C*A12	FC/MC/PC36A	1.00	0.92	1.08
C*(8,L)C*B12	FC/MC/PC36B	0.99	0.91	1.09
C*(8,L)C*C16	FC/MC/PC36C	0.99	0.94	1.06
C*(8,L)C*C20	FC/MC/PC36C	0.99	0.94	1.05
C*9C*B12	FC/MC/PC36B	1.00	0.93	1.08
C*9C*C16	FC/MC/PC36C	1.01	0.96	1.05
C*9C*C20	FC/MC/PC36C	0.99	0.92	1.08
C*(8,L)C*A12	FC/MC/PC37A	0.98	0.88	1.11
C*(8,L)C*B12	FC/MC/PC42B	1.00	0.95	1.05
C*(8,L)C*C16	FC/MC/PC42C	1.01	0.97	1.03
C*(8,L)C*C20	FC/MC/PC42C	1.00	0.96	1.04
C*9C*B12	FC/MC/PC42B	1.01	0.96	1.05
C*9C*C16	FC/MC/PC42C	1.00	0.95	1.06
C*9C*C20	FC/MC/PC42C	1.01	0.95	1.06
C*(8,L)C*B12	FC/MC/PC43B	0.99	0.92	1.07
C*(8,L)C*C16	FC/MC/PC43C	1.00	0.95	1.05
C*(8,L)C*C20	FC/MC/PC43C	0.99	0.94	1.06
C*9C*B12	FC/MC/PC43B	1.00	0.94	1.06
C*9C*C16	FC/MC/PC43C	1.00	0.95	1.06
C*9C*C20	FC/MC/PC43C	0.99	0.93	1.07
C*(8,L)C*C16	FC/MC/PC48C	1.03	0.90	1.14
C*(8,L)C*C20	FC/MC/PC48C	1.02	0.88	1.17
C*9C*C16	FC/MC/PC48C	1.03	0.90	1.15
C*9C*C20	FC/MC/PC48C	1.03	0.88	1.16
C*(8,L)C*C16	FC/PC60C	1.02	0.91	1.12
C*(8,L)C*C20	FC/PC60C	1.02	0.92	1.12
C*9C*C16	FC/PC60C	1.03	0.91	1.13
C*9C*C20	FC/PC60C	1.01	0.91	1.12
C*9C*D20	FC/MC/PC60D	1.02	0.92	1.12
C*9C*D20	FC/MC62D	1.00	0.98	1.02
C*(8,L)C*C16	HC42	1.00	0.95	1.05
C*(8,L)C*C20	HC42	0.99	0.93	1.06
C*9C*C16	HC42	1.00	0.94	1.06
C*9C*C20	HC42	1.00	0.95	1.05
C*(8,L)C*B12	HD48	0.95	0.80	1.19
C*(8,L)C*C16	HD48	0.95	0.84	1.14
C*(8,L)C*C20	HD48	0.95	0.79	1.20
C*9C*B12	HD48	0.95	0.78	1.22
C*9C*C16	HD48	0.96	0.84	1.14
C*9C*C20	HD48	0.96	0.79	1.22
C*(8,L)C*A12	UC36A	1.00	0.91	1.10
C*(8,L)C*B12	UC36B	0.99	0.90	1.10
C*(8,L)C*C16	UC36C	0.99	0.92	1.08
C*(8,L)C*C20	UC36C	0.99	0.92	1.07
C*9C*B12	UC36B	0.99	0.91	1.09
C*9C*C16	UC36C	1.00	0.94	1.07
C*9C*C20	UC36C	0.99	0.90	1.10
C*(8,L)C*B12	UC42B	0.90	0.78	1.17

Variable Speed Furnace	Coil	MBH	KW	COP
C*(8,L)C*C16	UC42C	0.92	0.83	1.11
C*(8,L)C*C20	UC42C	0.90	0.78	1.16
C*9C*B12	UC42B	0.93	0.82	1.14
C*9C*C16	UC42C	0.91	0.77	1.17
C*9C*C20	UC42C	0.91	0.78	1.16
C*(8,L)C*C16	UC48C	1.02	1.01	1.01
C*(8,L)C*C20	UC48C	1.01	0.98	1.03
C*9C*C16	UC48C	1.02	1.01	1.01
C*9C*C20	UC48C	1.03	0.98	1.04
C*(8,L)C*C16	UC60C	1.00	0.99	1.01
C*(8,L)C*C20	UC60C	1.00	0.99	1.01
C*9C*C16	UC60C	1.01	0.98	1.03
C*9C*C20	UC60C	1.00	0.97	1.03
C*9C*D20	UC60D	1.00	0.98	1.02
G*9V*B12	FC/MC/PC35B	1.00	0.92	1.09
G*9V*C16	FC/MC/PC35C	1.00	0.93	1.07
G*9V*C20	FC/MC/PC35C	0.99	0.91	1.09
G*9V*A12	FC/MC/PC36A	1.00	0.91	1.10
G*9V*B12	FC/MC/PC36B	1.00	0.93	1.08
G*9V*C16	FC/MC/PC36C	1.01	0.96	1.05
G*9V*C20	FC/MC/PC36C	0.99	0.92	1.08
G*9V*B12	FC/MC/PC42B	1.01	0.96	1.05
G*9V*C16	FC/MC/PC42C	1.00	0.95	1.06
G*9V*C20	FC/MC/PC42C	1.01	0.95	1.06
G*9V*A12	FC/MC/PC37A	1.01	0.93	1.09
G*9V*B12	FC/MC/PC43B	1.00	0.94	1.06
G*9V*C16	FC/MC/PC43C	1.00	0.95	1.06
G*9V*C20	FC/MC/PC43C	0.99	0.93	1.07
G*9V*C16	FC/MC/PC48C	1.03	0.90	1.15
G*9V*C20	FC/MC/PC48C	1.03	0.88	1.16
G*9V*C16	FC/PC60C	1.03	0.91	1.13
G*9V*C20	FC/PC60C	1.01	0.91	1.12
G*9V*D20	FC/MC/PC60D	1.02	0.92	1.12
G*9V*D20	FC/MC62D	1.00	0.98	1.02
G*9V*C16	HC42	1.00	0.94	1.06
G*9V*C20	HC42	1.00	0.95	1.05
G*9V*B12	HD48	0.95	0.78	1.22
G*9V*C16	HD48	0.96	0.84	1.14
G*9V*C20	HD48	0.96	0.79	1.22
G*9V*A12	UC36A	1.00	0.89	1.12
G*9V*B12	UC36B	0.99	0.91	1.09
G*9V*C16	UC36C	1.00	0.94	1.07
G*9V*C20	UC36C	0.99	0.90	1.10
G*9V*B12	UC42B	0.93	0.82	1.14
G*9V*C16	UC42C	0.91	0.77	1.17
G*9V*C20	UC42C	0.91	0.78	1.16
G*9V*C16	UC48C	1.02	1.01	1.01
G*9V*C20	UC48C	1.03	0.98	1.04
G*9V*C16	UC60C	1.01	0.98	1.03
G*9V*C20	UC60C	1.00	0.97	1.03
G*9V*D20	UC60D	1.00	0.98	1.02

HEATING PERFORMANCE DATA - HIGH CFM 2-STAGE OPERATION										
OUTDOOR UNIT MODEL NO.		HC8B036F1								
INDOOR COIL MODEL NO.		FC/MC62D + MV12D								
AIR TEMP. ENTERING OUTDOOR UNIT	AIR TEMP. ENTERING INDOOR COIL	ID CFM								
		1088			1188			1288		
		MBTUH	KW	C.O.P.	MBTUH	KW	C.O.P.	MBTUH	KW	C.O.P.
60	60	48.8	2.5	5.7	49.1	2.5	5.9	49.5	2.4	6.1
	70	47.7	2.8	5.0	48.0	2.7	5.1	48.3	2.6	5.3
	80	46.5	3.1	4.4	46.8	3.0	4.6	47.1	2.9	4.7
47	60	39.9	2.4	4.9	40.0	2.3	5.1	40.1	2.2	5.3
	70	39.3	2.6	4.3	39.4	2.6	4.5	39.5	2.5	4.6
	80	38.6	2.9	3.9	38.7	2.8	4.0	38.9	2.8	4.1
40	60	35.6	2.3	4.6	35.8	2.2	4.7	35.9	2.2	4.9
	70	35.0	2.5	4.0	35.1	2.5	4.1	35.3	2.4	4.3
	80	34.3	2.8	3.6	34.5	2.7	3.7	34.7	2.7	3.8
30	60	29.7	2.2	4.0	29.9	2.1	4.1	30.0	2.1	4.3
	70	29.2	2.4	3.5	29.4	2.4	3.6	29.6	2.3	3.7
	80	28.7	2.7	3.2	28.9	2.6	3.2	29.1	2.6	3.3
17	60	22.6	2.0	3.3	22.8	2.0	3.4	22.9	1.9	3.5
	70	22.4	2.2	2.9	22.5	2.2	3.0	22.7	2.2	3.1
	80	22.2	2.5	2.6	22.3	2.4	2.7	22.4	2.4	2.7
10	60	19.3	1.9	3.0	19.4	1.9	3.0	19.5	1.9	3.1
	70	19.3	2.1	2.6	19.3	2.1	2.7	19.3	2.1	2.7
	80	19.2	2.4	2.4	19.2	2.3	2.4	19.2	2.3	2.4

NOTE: ALL CAPACITIES INCLUDE INDOOR FAN HEAT AT 1250 BTUH/1000 CFM.

Multipliers for determining the performance with other indoor sections.

NOTE: KW RATING IS FOR OUTDOOR AND INDOOR UNITS.

HIGH CFM

Air Handler	Coil	MBH	KW	COP
AV36	-	1.00	0.98	1.02
AV/SV48	-	1.00	1.00	1.00
MV16C	FC/MC43C	1.00	1.00	1.00
MV16C	FC/MC48C	1.00	1.00	1.00
MV12D	FC/MC48D	1.00	1.00	1.00
MV12D	FC/MC60D	1.00	1.00	1.00

Variable Speed Furnace	Coil	MBH	KW	COP
(F,L)C8V*B16	FC/MC/PC43B	1.00	0.97	1.03
(F,L)C8V*C16	FC/MC/PC43C	1.00	0.98	1.02
(F,L)C8V*C20	FC/MC/PC43C	1.00	0.98	1.02
FC9(C,V)*B12	FC/MC/PC43B	1.00	0.96	1.04
FC9(C,V)*C16	FC/MC/PC43C	1.00	0.97	1.03
FC9(C,V)*C20	FC/MC/PC43C	1.00	0.97	1.03
(F,L)C8V*C16	FC/MC/PC48C	1.00	1.00	1.00
(F,L)C8V*C20	FC/MC/PC48C	1.00	1.00	1.00
FC9(C,V)*C16	FC/MC/PC48C	1.00	0.98	1.02
FC9(C,V)*C20	FC/MC/PC48C	1.00	0.98	1.02
FC9(C,V)*D20	FC/MC/PC48D	1.00	0.98	1.02
(F,L)C8V*C16	FC/PC60C	1.00	1.00	1.00
(F,L)C8V*C20	FC/PC60C	1.00	1.00	1.00
FC9(C,V)*C16	FC/PC60C	1.00	0.98	1.02
FC9(C,V)*C20	FC/PC60C	1.00	0.98	1.02
FC9(C,V)*D20	FC/MC/PC60D	1.00	0.98	1.02
(F,L)C8V*C20	FC/MC62D	1.00	1.00	1.00
FC9(C,V)*C20	FC/MC62D	1.00	0.98	1.02
FC9(C,V)*D20	FC/MC62D	1.00	0.98	1.02
(F,L)C8V*C16	HC42	1.00	0.98	1.02
(F,L)C8V*C20	HC42	1.00	1.00	1.00
FC9(C,V)*C16	HC42	1.00	0.97	1.03
FC9(C,V)*C20	HC42	1.00	0.97	1.03
C*(8,L)C*B12	FC/MC/PC35B	1.01	0.90	1.04
C*(8,L)C*C16	FC/MC/PC35C	1.00	0.92	1.00

Continued on Page 51.

Variable Speed Furnace	Coil	MBH	KW	COP
C*(8,L)C*C20	FC/MC/PC35C	0.99	0.92	1.00
C*9C*B12	FC/MC/PC35B	1.00	0.91	1.03
C*9C*C16	FC/MC/PC35C	1.00	0.92	1.01
C*9C*C20	FC/MC/PC35C	1.01	0.92	1.01
C*(8,L)C*A12	FC/MC/PC36A	1.00	0.89	1.04
C*(8,L)C*B12	FC/MC/PC36B	1.00	0.91	1.02
C*(8,L)C*C16	FC/MC/PC36C	0.99	0.92	1.00
C*(8,L)C*C20	FC/MC/PC36C	0.99	0.92	1.00
C*9C*B12	FC/MC/PC36B	1.00	0.91	1.02
C*9C*C16	FC/MC/PC36C	0.99	0.92	1.00
C*9C*C20	FC/MC/PC36C	1.01	0.93	1.00
C*(8,L)C*A12	FC/MC/PC37A	0.99	0.89	1.03
C*(8,L)C*B12	FC/MC/PC42B	1.00	0.93	0.99
C*(8,L)C*C16	FC/MC/PC42C	0.99	0.95	0.96
C*(8,L)C*C20	FC/MC/PC42C	0.99	0.95	0.96
C*9C*B12	FC/MC/PC42B	1.01	0.91	1.02
C*9C*C16	FC/MC/PC42C	1.00	0.94	0.98
C*9C*C20	FC/MC/PC42C	1.01	0.95	0.98
C*(8,L)C*B12	FC/MC/PC43B	1.01	0.93	1.01
C*(8,L)C*C16	FC/MC/PC43C	1.00	0.95	0.97
C*(8,L)C*C20	FC/MC/PC43C	1.00	0.96	0.96
C*9C*B12	FC/MC/PC43B	1.01	0.93	1.01
C*9C*C16	FC/MC/PC43C	1.01	0.94	0.99
C*9C*C20	FC/MC/PC43C	1.00	0.95	0.97
C*(8,L)C*C16	FC/MC/PC48C	1.01	0.96	0.97
C*(8,L)C*C20	FC/MC/PC48C	1.00	0.95	0.97
C*9C*C16	FC/MC/PC48C	1.01	0.95	0.99
C*9C*C20	FC/MC/PC48C	1.02	0.95	0.99
C*(8,L)C*C16	FC/PC60C	1.00	0.96	0.96
C*(8,L)C*C20	FC/PC60C	1.00	0.97	0.96
C*9C*C16	FC/PC60C	1.01	0.95	0.99
C*9C*C20	FC/PC60C	1.02	0.96	0.98
C*9C*D20	FC/MC/PC60D	1.01	0.96	0.97
C*9C*D20	FC/MC62D	1.00	0.98	0.95
C*(8,L)C*C16	HC42	1.00	0.96	0.97
C*(8,L)C*C20	HC42	1.00	0.96	0.96
C*9C*C16	HC42	1.01	0.94	0.99
C*9C*C20	HC42	1.00	0.95	0.97
C*(8,L)C*B12	HD48	0.99	0.85	1.07
C*(8,L)C*C16	HD48	0.98	0.87	1.04
C*(8,L)C*C20	HD48	0.98	0.86	1.05
C*9C*B12	HD48	0.99	0.83	1.10
C*9C*C16	HD48	0.99	0.86	1.06
C*9C*C20	HD48	1.00	0.88	1.05
C*(8,L)C*A12	UC36A	1.00	0.88	1.05
C*(8,L)C*B12	UC36B	1.00	0.90	1.03
C*(8,L)C*C16	UC36C	0.99	0.91	1.01
C*(8,L)C*C20	UC36C	0.99	0.91	1.01
C*9C*B12	UC36B	1.00	0.90	1.03
C*9C*C16	UC36C	0.99	0.91	1.01
C*9C*C20	UC36C	1.00	0.91	1.02
C*(8,L)C*B12	UC42B	0.99	0.91	1.01

Variable Speed Furnace	Coil	MBH	KW	COP
C*(8,L)C*C16	UC42C	0.99	0.93	0.99
C*(8,L)C*C20	UC42C	0.99	0.93	0.99
C*9C*B12	UC42B	1.00	0.89	1.04
C*9C*C16	UC42C	0.99	0.91	1.01
C*9C*C20	UC42C	1.00	0.93	1.00
C*(8,L)C*C16	UC48C	1.00	1.00	0.93
C*(8,L)C*C20	UC48C	1.00	0.99	0.93
C*9C*C16	UC48C	1.01	0.99	0.95
C*9C*C20	UC48C	1.02	0.99	0.96
C*(8,L)C*C16	UC60C	1.00	0.99	0.93
C*(8,L)C*C20	UC60C	1.00	0.99	0.94
C*9C*C16	UC60C	1.01	0.97	0.97
C*9C*C20	UC60C	1.02	0.99	0.95
C*9C*D20	UC60D	1.00	0.98	0.95
G*9V*B12	FC/MC/PC35B	1.00	0.91	1.03
G*9V*C16	FC/MC/PC35C	1.00	0.92	1.01
G*9V*C20	FC/MC/PC35C	1.01	0.92	1.01
G*9V*A12	FC/MC/PC36A	1.01	0.89	1.05
G*9V*B12	FC/MC/PC36B	1.00	0.91	1.02
G*9V*C16	FC/MC/PC36C	0.99	0.92	1.00
G*9V*C20	FC/MC/PC36C	1.01	0.93	1.00
G*9V*B12	FC/MC/PC42B	1.01	0.91	1.02
G*9V*C16	FC/MC/PC42C	1.00	0.94	0.98
G*9V*C20	FC/MC/PC42C	1.01	0.95	0.98
G*9V*A12	FC/MC/PC37A	1.00	0.90	1.03
G*9V*B12	FC/MC/PC43B	1.01	0.93	1.01
G*9V*C16	FC/MC/PC43C	1.01	0.94	0.99
G*9V*C20	FC/MC/PC43C	1.00	0.95	0.97
G*9V*C16	FC/MC/PC48C	1.01	0.95	0.99
G*9V*C20	FC/MC/PC48C	1.02	0.95	0.99
G*9V*C16	FC/PC60C	1.01	0.95	0.99
G*9V*C20	FC/PC60C	1.02	0.96	0.98
G*9V*D20	FC/MC/PC60D	1.01	0.96	0.97
G*9V*D20	FC/MC62D	1.00	0.98	0.95
G*9V*C16	HC42	1.01	0.94	0.99
G*9V*C20	HC42	1.00	0.95	0.97
G*9V*B12	HD48	0.99	0.83	1.10
G*9V*C16	HD48	0.99	0.86	1.06
G*9V*C20	HD48	1.00	0.88	1.05
G*9V*A12	UC36A	1.00	0.88	1.06
G*9V*B12	UC36B	1.00	0.90	1.03
G*9V*C16	UC36C	0.99	0.91	1.01
G*9V*C20	UC36C	1.00	0.91	1.02
G*9V*B12	UC42B	1.00	0.89	1.04
G*9V*C16	UC42C	0.99	0.91	1.01
G*9V*C20	UC42C	1.00	0.93	1.00
G*9V*C16	UC48C	1.01	0.99	0.95
G*9V*C20	UC48C	1.02	0.99	0.96
G*9V*C16	UC60C	1.01	0.97	0.97
G*9V*C20	UC60C	1.02	0.99	0.95
G*9V*D20	UC60D	1.00	0.98	0.95

HEATING PERFORMANCE DATA - LOW CFM 1-STAGE OPERATION										
OUTDOOR UNIT MODEL NO.		HC8B048F1								
INDOOR COIL MODEL NO.		FC/MC62D + MV20D								
AIR TEMP. ENTERING OUTDOOR UNIT	AIR TEMP. ENTERING INDOOR COIL	ID CFM								
		973			1023			1073		
		MBTUH	KW	C.O.P.	MBTUH	KW	C.O.P.	MBTUH	KW	C.O.P.
60	60	41.4	2.5	4.9	41.6	2.5	5.0	41.8	2.4	5.1
	70	40.7	2.8	4.3	40.8	2.7	4.3	40.9	2.7	4.4
	80	40.0	3.1	3.8	40.0	3.0	3.8	40.0	3.0	3.9
47	60	33.7	2.4	4.0	33.8	2.4	4.1	34.0	2.4	4.2
	70	33.2	2.7	3.6	33.3	2.7	3.7	33.4	2.6	3.7
	80	32.8	3.0	3.2	32.8	2.9	3.3	32.8	2.9	3.3
40	60	29.7	2.4	3.7	29.8	2.3	3.7	29.9	2.3	3.8
	70	29.4	2.6	3.3	29.4	2.6	3.3	29.4	2.6	3.4
	80	29.1	2.9	2.9	29.0	2.9	3.0	28.9	2.8	3.0
30	60	24.4	2.3	3.1	24.4	2.3	3.2	24.5	2.2	3.2
	70	24.2	2.6	2.8	24.1	2.5	2.8	24.1	2.5	2.8
	80	23.9	2.8	2.5	23.8	2.8	2.5	23.7	2.7	2.5
17	60	18.1	2.2	2.4	18.2	2.2	2.5	18.2	2.1	2.5
	70	18.0	2.5	2.1	18.0	2.4	2.2	18.1	2.4	2.2
	80	17.8	2.7	1.9	17.9	2.7	2.0	18.0	2.6	2.0
10	60	15.0	2.2	2.0	15.0	2.1	2.1	15.0	2.1	2.1
	70	14.8	2.4	1.8	14.9	2.4	1.8	14.9	2.4	1.9
	80	14.6	2.7	1.6	14.7	2.6	1.6	14.9	2.6	1.7

NOTE: ALL CAPACITIES INCLUDE INDOOR FAN HEAT AT 1250 BTUH/1000 CFM.

Multipliers for determining the performance with other indoor sections.

NOTE: KW RATING IS FOR OUTDOOR AND INDOOR UNITS.

Continued on Page 53.

LOW CFM

Air Handler	Coil	MBH	KW	COP
AV/SV48	-	1.00	0.98	1.02
AV/SV60	-	1.00	0.98	1.02
MV16C	FC/MC48C	1.00	0.98	1.02
MV20D	FC/MC48D	1.00	0.98	1.02
MV20D	FC/MC60D	1.00	0.98	1.02

Variable Speed Furnace	Coil	MBH	KW	COP
(F,L)C8V*C16	FC/MC/PC48C	0.98	0.98	1.02
(F,L)C8V*C20	FC/MC/PC48C	1.00	0.98	1.02
FC9(C,V)*C16	FC/MC/PC48C	1.00	1.00	1.00
FC9(C,V)*C20	FC/MC/PC48C	1.00	0.97	1.03
FC9(C,V)*D20	FC/MC/PC48D	1.00	0.97	1.03
(F,L)C8V*C16	FC/PC60C	0.98	0.98	1.02
(F,L)C8V*C20	FC/PC60C	1.00	0.98	1.02
FC9(C,V)*C16	FC/PC60C	0.98	1.03	0.97
FC9(C,V)*C20	FC/PC60C	0.98	1.03	0.97
FC9(C,V)*D20	FC/MC/PC60D	1.00	0.97	1.03
(F,L)C8V*C20	FC/MC62D	1.00	0.98	1.02
FC9(C,V)*C20	FC/MC62D	0.98	1.03	0.97
FC9(C,V)*D20	FC/MC62D	1.00	0.97	1.03
C*(8,L)C*C16	FC/MC/PC48C	0.99	0.95	1.04
C*(8,L)C*C20	FC/MC/PC48C	0.99	0.95	1.05
C*9C*C16	FC/MC/PC48C	1.03	0.96	1.07
C*9C*C20	FC/MC/PC48C	1.03	0.97	1.07
C*9C*D20	FC/MC/PC48D	0.99	0.95	1.05
C*(8,L)C*C16	FC/PC60C	0.99	0.96	1.03
C*(8,L)C*C20	FC/PC60C	0.99	0.97	1.02
C*9C*C16	FC/PC60C	0.99	0.95	1.04
C*9C*C20	FC/PC60C	0.99	0.96	1.03
C*9C*D20	FC/MC/PC60D	1.00	0.97	1.03
C*9C*D20	FC/MC62D	0.99	0.98	1.01
C*9C*D20	HC60	1.06	1.02	1.04
C*(8,L)C*C16	HD48	1.01	0.86	1.17
C*(8,L)C*C20	HD48	1.01	0.86	1.18
C*9C*C16	HD48	1.01	0.86	1.17
C*9C*C20	HD48	1.01	0.86	1.17

Variable Speed Furnace	Coil	MBH	KW	COP
C*9C*D20	HD48	1.01	0.86	1.18
C*(8,L)C*C16	HD60	1.02	0.89	1.14
C*(8,L)C*C20	HD60	1.02	0.90	1.13
C*9C*C16	HD60	1.02	0.89	1.15
C*9C*C20	HD60	1.02	0.89	1.14
C*9C*D20	HD60	1.02	0.89	1.15
C*(8,L)C*C16	UC48C	1.06	1.00	1.05
C*(8,L)C*C20	UC48C	1.06	1.00	1.06
C*9C*C16	UC48C	1.06	1.00	1.06
C*9C*C20	UC48C	1.06	1.00	1.06
C*9C*D20	UC48D	1.06	1.00	1.06
C*(8,L)C*C16	UC60C	1.04	0.99	1.05
C*(8,L)C*C20	UC60C	1.04	1.00	1.04
C*9C*C16	UC60C	1.05	0.99	1.06
C*9C*C20	UC60C	1.05	0.99	1.06
C*9C*D20	UC60D	1.05	0.99	1.06
G*9V*C16	FC/MC/PC48C	1.03	0.96	1.07
G*9V*C20	FC/MC/PC48C	1.03	0.97	1.07
G*9V*D20	FC/MC/PC48D	0.99	0.95	1.05
G*9V*C16	FC/PC60C	0.99	0.95	1.04
G*9V*C20	FC/PC60C	0.99	0.96	1.03
G*9V*D20	FC/MC/PC60D	1.00	0.97	1.03
G*9V*D20	FC/MC62D	0.99	0.98	1.01
G*9V*D20	HC60	1.06	1.02	1.04
G*9V*C16	HD48	1.01	0.86	1.17
G*9V*C20	HD48	1.01	0.86	1.17
G*9V*D20	HD48	1.01	0.86	1.18
G*9V*C16	HD60	1.02	0.89	1.15
G*9V*C20	HD60	1.02	0.89	1.14
G*9V*D20	HD60	1.02	0.89	1.15
G*9V*C16	UC48C	1.06	1.00	1.06
G*9V*C20	UC48C	1.06	1.00	1.06
G*9V*D20	UC48D	1.06	1.00	1.06
G*9V*C16	UC60C	1.05	0.99	1.06
G*9V*C20	UC60C	1.05	0.99	1.06
G*9V*D20	UC60D	1.05	0.99	1.06

HEATING PERFORMANCE DATA - HIGH CFM 2-STAGE OPERATION										
OUTDOOR UNIT MODEL NO.		HC8B048F1								
INDOOR COIL MODEL NO.		FC/MC62D + MV20D								
AIR TEMP. ENTERING OUTDOOR UNIT	AIR TEMP. ENTERING INDOOR COIL	ID CFM								
		1423			1523			1623		
		MBTUH	KW	C.O.P.	MBTUH	KW	C.O.P.	MBTUH	KW	C.O.P.
60	60	59.6	3.3	5.3	60.0	3.2	5.4	60.4	3.2	5.6
	70	58.2	3.6	4.7	58.6	3.5	4.9	59.0	3.5	5.0
	80	56.8	3.9	4.3	57.2	3.8	4.4	57.6	3.8	4.5
47	60	49.4	3.1	4.7	49.6	3.0	4.8	49.9	3.0	4.9
	70	48.4	3.4	4.2	48.6	3.3	4.3	48.9	3.3	4.4
	80	47.4	3.6	3.8	47.6	3.6	3.9	47.8	3.5	4.0
40	60	44.4	3.0	4.4	44.5	2.9	4.4	44.5	2.9	4.5
	70	43.7	3.3	3.9	43.8	3.2	4.0	43.8	3.2	4.1
	80	43.0	3.6	3.5	43.1	3.5	3.6	43.1	3.4	3.7
30	60	38.0	2.8	3.9	38.1	2.8	4.0	38.2	2.8	4.1
	70	37.5	3.1	3.5	37.6	3.1	3.6	37.7	3.0	3.6
	80	37.0	3.4	3.2	37.1	3.3	3.3	37.2	3.3	3.3
17	60	30.4	2.7	3.3	30.5	2.6	3.4	30.6	2.6	3.5
	70	30.1	2.9	3.0	30.2	2.9	3.1	30.3	2.9	3.1
	80	29.8	3.2	2.8	29.9	3.1	2.8	30.0	3.1	2.8
10	60	26.7	2.6	3.1	26.8	2.5	3.1	26.9	2.5	3.2
	70	26.4	2.8	2.8	26.5	2.8	2.8	26.6	2.7	2.8
	80	26.1	3.0	2.5	26.3	3.0	2.6	26.4	3.0	2.6

NOTE: ALL CAPACITIES INCLUDE INDOOR FAN HEAT AT 1250 BTUH/1000 CFM.

Multipliers for determining the performance with other indoor sections.

NOTE: KW RATING IS FOR OUTDOOR AND INDOOR UNITS.

Continued on Page 55.

HIGH CFM

Air Handler	Coil	MBH	KW	COP
AV/SV48	–	1.00	0.98	1.02
AV/SV60	–	1.00	0.97	1.03
MV16C	FC/MC48C	1.00	0.98	1.02
MV20D	FC/MC48D	1.00	1.00	1.00
MV20D	FC/MC60D	1.00	1.00	1.00

Variable Speed Furnace	Coil	MBH	KW	COP
(F,L)C8V*C16	FC/MC/PC48C	1.00	0.96	1.04
(F,L)C8V*C20	FC/MC/PC48C	1.00	0.96	1.04
FC9(C,V)*C16	FC/MC/PC48C	1.00	0.95	1.05
FC9(C,V)*C20	FC/MC/PC48C	1.00	0.96	1.04
FC9(C,V)*D20	FC/MC/PC48D	1.00	0.97	1.03
(F,L)C8V*C16	FC/PC60C	1.00	0.96	1.04
(F,L)C8V*C20	FC/PC60C	1.00	0.96	1.04
FC9(C,V)*C16	FC/PC60C	1.00	0.95	1.05
FC9(C,V)*C20	FC/PC60C	1.00	0.96	1.04
FC9(C,V)*D20	FC/MC/PC60D	1.00	0.97	1.03
(F,L)C8V*C20	FC/MC62D	1.00	0.96	1.04
FC9(C,V)*C20	FC/MC62D	1.00	0.96	1.04
FC9(C,V)*D20	FC/MC62D	1.00	0.97	1.03
C*(8,L)C*C16	FC/MC/PC48C	1.01	0.95	1.02
C*(8,L)C*C20	FC/MC/PC48C	1.01	0.95	1.02
C*9C*C16	FC/MC/PC48C	1.01	0.94	1.03
C*9C*C20	FC/MC/PC48C	1.01	0.94	1.03
C*9C*D20	FC/MC/PC48D	1.01	0.95	1.03
C*(8,L)C*C16	FC/PC60C	1.01	0.96	1.01
C*(8,L)C*C20	FC/PC60C	1.00	0.97	0.99
C*9C*C16	FC/PC60C	1.01	0.95	1.02
C*9C*C20	FC/PC60C	1.01	0.95	1.02
C*9C*D20	FC/MC/PC60D	1.01	0.95	1.02
C*9C*D20	FC/MC62D	1.01	0.97	1.00
C*9C*D20	HC60	1.01	0.98	0.99
C*(8,L)C*C16	HD48	1.00	0.88	1.08
C*(8,L)C*C20	HD48	1.00	0.88	1.08
C*9C*C16	HD48	1.00	0.87	1.09
C*9C*C20	HD48	1.00	0.88	1.09

Variable Speed Furnace	Coil	MBH	KW	COP
C*9C*D20	HD48	1.00	0.88	1.09
C*(8,L)C*C16	HD60	1.00	0.90	1.06
C*(8,L)C*C20	HD60	0.99	0.92	1.04
C*9C*C16	HD60	1.00	0.90	1.07
C*9C*C20	HD60	1.00	0.90	1.07
C*9C*D20	HD60	1.00	0.90	1.06
C*(8,L)C*C16	UC48C	1.01	0.97	1.00
C*(8,L)C*C20	UC48C	1.01	0.97	1.00
C*9C*C16	UC48C	1.01	0.97	1.01
C*9C*C20	UC48C	1.01	0.97	1.01
C*9C*D20	UC48D	1.01	0.97	1.01
C*(8,L)C*C16	UC60C	1.01	0.97	1.00
C*(8,L)C*C20	UC60C	1.01	0.99	0.98
C*9C*C16	UC60C	1.01	0.97	1.01
C*9C*C20	UC60C	1.01	0.97	1.01
C*9C*D20	UC60D	1.01	0.97	1.00
G*9V*C16	FC/MC/PC48C	1.01	0.94	1.03
G*9V*C20	FC/MC/PC48C	1.01	0.94	1.03
G*9V*D20	FC/MC/PC48D	1.01	0.95	1.03
G*9V*C16	FC/PC60C	1.01	0.95	1.02
G*9V*C20	FC/PC60C	1.01	0.95	1.02
G*9V*D20	FC/MC/PC60D	1.01	0.95	1.02
G*9V*D20	FC/MC62D	1.01	0.97	1.00
G*9V*D20	HC60	1.01	0.98	0.99
G*9V*C16	HD48	1.00	0.87	1.09
G*9V*C20	HD48	1.00	0.88	1.09
G*9V*D20	HD48	1.00	0.88	1.09
G*9V*C16	HD60	1.00	0.90	1.07
G*9V*C20	HD60	1.00	0.90	1.07
G*9V*D20	HD60	1.00	0.90	1.06
G*9V*C16	UC48C	1.01	0.97	1.01
G*9V*C20	UC48C	1.01	0.97	1.01
G*9V*D20	UC48D	1.01	0.97	1.01
G*9V*C16	UC60C	1.01	0.97	1.01
G*9V*C20	UC60C	1.01	0.97	1.01
G*9V*D20	UC60D	1.01	0.97	1.00

HEATING PERFORMANCE DATA - LOW CFM 1-STAGE OPERATION										
OUTDOOR UNIT MODEL NO.		HC8B060F1								
INDOOR COIL MODEL NO.		FC/MC62D + MV20D								
AIR TEMP. ENTERING OUTDOOR UNIT	AIR TEMP. ENTERING INDOOR COIL	ID CFM								
		1066			1116			1166		
		MBTUH	KW	C.O.P.	MBTUH	KW	C.O.P.	MBTUH	KW	C.O.P.
60	60	50.9	3.5	4.3	51.1	3.4	4.4	51.2	3.4	4.5
	70	50.1	3.9	3.8	50.2	3.8	3.9	50.4	3.7	4.0
	80	49.3	4.2	3.4	49.4	4.1	3.5	49.6	4.1	3.6
47	60	41.8	3.3	3.7	41.9	3.3	3.7	41.9	3.2	3.8
	70	41.3	3.7	3.3	41.3	3.6	3.3	41.3	3.6	3.4
	80	40.7	4.1	2.9	40.8	4.0	3.0	40.8	3.9	3.0
40	60	37.0	3.3	3.3	36.9	3.2	3.4	36.8	3.2	3.4
	70	36.9	3.6	3.0	36.9	3.6	3.0	36.9	3.5	3.1
	80	36.9	4.0	2.7	36.9	4.0	2.7	36.9	3.9	2.8
30	60	31.3	3.2	2.9	31.3	3.1	2.9	31.3	3.1	3.0
	70	31.3	3.5	2.6	31.4	3.5	2.6	31.4	3.5	2.7
	80	31.4	3.9	2.4	31.5	3.9	2.4	31.5	3.8	2.4
17	60	24.2	3.0	2.3	24.3	3.0	2.4	24.3	3.0	2.4
	70	24.8	3.5	2.1	25.0	3.5	2.1	25.2	3.5	2.1
	80	25.4	4.0	1.9	25.7	3.9	1.9	26.0	3.9	1.9
10	60	21.0	3.0	2.1	21.0	2.9	2.1	21.1	2.9	2.1
	70	21.6	3.5	1.8	21.8	3.5	1.8	22.0	3.5	1.9
	80	22.2	4.0	1.6	22.6	4.0	1.7	23.0	4.0	1.7

NOTE: ALL CAPACITIES INCLUDE INDOOR FAN HEAT AT 1250 BTUH/1000 CFM.

Multipliers for determining the performance with other indoor sections.

NOTE: KW RATING IS FOR OUTDOOR AND INDOOR UNITS.

LOW CFM

Air Handler	Coil	MBH	KW	COP
AV/SV60	-	1.00	1.00	1.00
MV20D	FC/MC60D	1.00	1.00	1.00

Variable Speed Furnace	Coil	MBH	KW	COP
(F,L)C8V*C20	FC/PC60C	1.00	0.98	1.02
FC9(C,V)*C20	FC/PC60C	0.98	0.98	1.02
FC9(C,V)*D20	FC/MC/PC60D	0.98	0.98	1.02
(F,L)C8V*C20	FC/MC62D	1.00	0.98	1.02
FC9(C,V)*C20	FC/MC62D	0.98	0.98	1.02
FC9(C,V)*D20	FC/MC62D	0.98	0.98	1.02
C*(8,L)C*C20	FC/PC60C	0.99	0.93	1.06
C*9C*C20	FC/PC60C	0.99	0.93	1.07
C*(8,L)C*C20	FC/MC/PC60D	0.99	0.93	1.07
C*9C*C20	FC/MC/PC60D	1.00	0.93	1.08
C*9C*D20	FC/MC/PC60D	1.00	0.94	1.06
C*(8,L)C*C20	FC/MC62D	0.99	0.95	1.05
C*9C*C20	FC/MC62D	0.99	0.94	1.06

Variable Speed Furnace	Coil	MBH	KW	COP
C*9C*D20	FC/MC62D	1.00	0.96	1.04
C*9C*D20	HC60	1.01	0.99	1.02
C*(8,L)C*C20	HD60	0.97	0.84	1.16
C*9C*C20	HD60	0.98	0.85	1.14
C*9C*D20	HD60	0.98	0.86	1.14
C*(8,L)C*C20	UC60C	1.00	0.96	1.04
C*9C*C20	UC60C	1.00	0.95	1.06
C*9C*D20	UC60D	1.01	0.97	1.04
G*9V*C20	FC/PC60C	0.99	0.93	1.07
G*9V*C20	FC/MC/PC60D	1.00	0.93	1.08
G*9V*D20	FC/MC/PC60D	1.00	0.94	1.06
G*9V*C20	FC/MC62D	0.99	0.94	1.06
G*9V*D20	FC/MC62D	1.00	0.96	1.04
G*9V*D20	HC60	1.01	0.99	1.02
G*9V*C20	HD60	0.98	0.85	1.14
G*9V*D20	HD60	0.98	0.86	1.14
G*9V*C20	UC60C	1.00	0.95	1.06
G*9V*D20	UC60D	1.01	0.97	1.04

HEATING PERFORMANCE DATA - HIGH CFM 2-STAGE OPERATION										
OUTDOOR UNIT MODEL NO.		HC8B060F1								
INDOOR COIL MODEL NO.		FC/MC62D + MV20D								
AIR TEMP. ENTERING OUTDOOR UNIT	AIR TEMP. ENTERING INDOOR COIL	ID CFM								
		1621			1721			1821		
		MBTUH	KW	C.O.P.	MBTUH	KW	C.O.P.	MBTUH	KW	C.O.P.
60	60	72.8	4.3	5.0	73.2	4.2	5.1	73.7	4.1	5.2
	70	71.5	4.7	4.5	71.9	4.6	4.6	72.3	4.5	4.7
	80	70.2	5.1	4.1	70.6	5.0	4.1	70.9	4.9	4.2
47	60	60.3	4.0	4.4	60.5	3.9	4.5	60.8	3.9	4.6
	70	59.4	4.4	4.0	59.7	4.3	4.1	59.9	4.2	4.2
	80	58.6	4.7	3.6	58.8	4.7	3.7	59.0	4.6	3.8
40	60	53.7	3.8	4.1	53.8	3.8	4.2	53.9	3.7	4.3
	70	53.1	4.2	3.7	53.2	4.1	3.8	53.3	4.1	3.8
	80	52.4	4.6	3.4	52.6	4.5	3.4	52.8	4.4	3.5
30	60	45.9	3.6	3.7	46.1	3.6	3.8	46.3	3.5	3.8
	70	45.4	4.0	3.3	45.6	3.9	3.4	45.7	3.9	3.5
	80	45.0	4.3	3.0	45.1	4.3	3.1	45.1	4.2	3.1
17	60	36.6	3.4	3.2	36.7	3.3	3.2	36.8	3.3	3.3
	70	36.6	3.7	2.9	36.6	3.7	2.9	36.7	3.6	3.0
	80	36.5	4.1	2.6	36.6	4.0	2.7	36.6	4.0	2.7
10	60	32.5	3.2	2.9	32.6	3.2	3.0	32.6	3.2	3.0
	70	32.5	3.6	2.7	32.5	3.5	2.7	32.6	3.5	2.7
	80	32.5	3.9	2.4	32.5	3.9	2.5	32.6	3.8	2.5

NOTE: ALL CAPACITIES INCLUDE INDOOR FAN HEAT AT 1250 BTUH/1000 CFM.

Multipliers for determining the performance with other indoor sections.

NOTE: KW RATING IS FOR OUTDOOR AND INDOOR UNITS.

HIGH CFM

Air Handler	Coil	MBH	KW	COP
AV/SV60	—	1.00	0.98	1.02
MV20D	FC/MC60D	1.00	1.00	1.00

Variable Speed Furnace	Coil	MBH	KW	COP
(F,L)C8V*C20	FC/PC60C	1.00	0.97	1.03
FC9(C,V)*C20	FC/PC60C	1.00	0.97	1.03
FC9(C,V)*D20	FC/MC/PC60D	1.00	0.97	1.03
(F,L)C8V*C20	FC/MC62D	1.00	0.97	1.03
FC9(C,V)*C20	FC/MC62D	1.00	0.97	1.03
FC9(C,V)*D20	FC/MC62D	1.00	0.97	1.03
C*(8,L)C*C20	FC/PC60C	0.99	0.94	0.96
C*9C*C20	FC/PC60C	1.00	0.93	0.99
C*(8,L)C*C20	FC/MC/PC60D	0.99	0.94	0.96
C*9C*C20	FC/MC/PC60D	1.00	0.93	0.99
C*9C*D20	FC/MC/PC60D	1.00	0.93	0.98
C*(8,L)C*C20	FC/MC62D	0.99	0.97	0.94
C*9C*C20	FC/MC62D	1.00	0.95	0.97

Variable Speed Furnace	Coil	MBH	KW	COP
C*9C*D20	FC/MC62D	1.00	0.95	0.96
C*9C*D20	HC60	1.00	0.97	0.95
C*(8,L)C*C20	HD60	0.98	0.88	1.03
C*9C*C20	HD60	0.99	0.87	1.04
C*9C*D20	HD60	0.99	0.87	1.04
C*(8,L)C*C20	UC60C	0.99	0.96	0.95
C*9C*C20	UC60C	1.00	0.95	0.97
C*9C*D20	UC60D	1.00	0.95	0.96
G*9V*C20	FC/PC60C	1.00	0.93	0.99
G*9V*C20	FC/MC/PC60D	1.00	0.93	0.99
G*9V*D20	FC/MC/PC60D	1.00	0.93	0.98
G*9V*C20	FC/MC62D	1.00	0.95	0.97
G*9V*D20	FC/MC62D	1.00	0.95	0.96
G*9V*D20	HC60	1.00	0.97	0.95
G*9V*C20	HD60	0.99	0.87	1.04
G*9V*D20	HD60	0.99	0.87	1.04
G*9V*C20	UC60C	1.00	0.95	0.97
G*9V*D20	UC60D	1.00	0.95	0.96

