



SST (SUPER SLIM TWIN) ELECTRONIC AIR CLEANER

High Efficiency Electronic Air Cleaner



SST Series

FEATURES

- New and improved high efficiency electronic design.
- Four standard sizes.
- Easy to install.
- Snap-on power door.
- Twin 5" collecting cells.

SPECIFICATIONS

Dimensions Refer to bottom of page for rough-in dimensions
 Sizing See page 203

PARTS AND ACCESSORIES See page 205 for additional parts and accessories

- Replacement charcoal filters: Refer to page 205
- F859-0381 – Air Flow Monitor Kit
- F881-0240 – 240 Volt Conversion Kit

TECHNICAL HELP

Sizing See page 203
 Parts view See page 205



Model Number	CFM	Recommended CFM	A/C Tonnage	BTU Input Range	Power Requirements	Shipping Weight
SST1000-100*	1000	600-1200	up to 3.0	up to 120,000	120 VAC, .3A, 50/60 Hz	42 lbs.
SST1000-150*						
SST1400-100*	1400	1000-1600	up to 4.0	up to 160,000	120 VAC, .3A, 50/60 Hz	46 lbs.
SST1400-150*						
SST1600-100*	1600	1200-1800	up to 4.5	up to 180,000	120 VAC, .3A, 50/60 Hz	46 lbs.
SST1600-150*						
SST2000-100*	2000	1600-2200	up to 5.5	up to 220,000	120 VAC, .3A, 50/60 Hz	48 lbs.
SST2000-150*						

*-100 Models (No Air Switch)

*-150 Models (With Air Switch and 6' Electrical Cord)

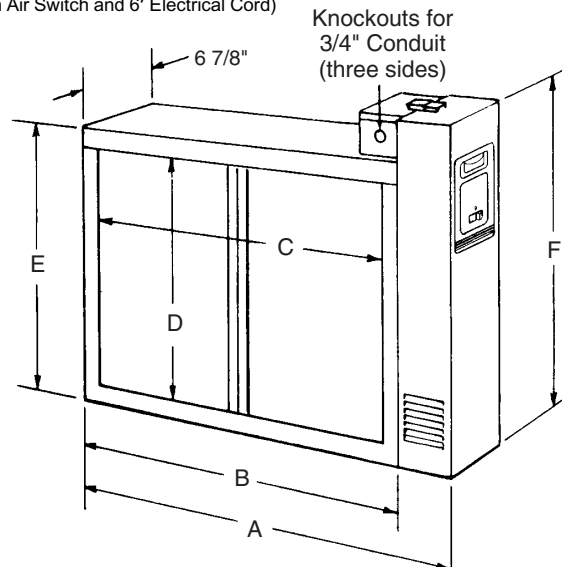

DIMENSIONAL DATA (-100 and -150 models)

Model Number	Dimensions in inches					
	A	B	C	D	E	F
SST1000	23 ³ / ₄	21 ⁵ / ₁₆	18 ⁵ / ₈	13 ⁹ / ₁₆	16 ⁷ / ₁₆	19 ¹ / ₁₆
SST1400	29 ¹¹ / ₁₆	26 ¹ / ₄	23 ⁵ / ₈	13 ⁹ / ₁₆	16 ⁷ / ₁₆	19 ¹ / ₁₆
SST1600	25 ¹ / ₂	21 ⁵ / ₁₆	18 ⁵ / ₈	17 ³ / ₄	20 ⁵ / ₈	23 ³ / ₈
SST2000	29 ¹¹ / ₁₆	26 ¹ / ₄	23 ⁵ / ₈	17 ³ / ₄	20 ⁵ / ₈	23 ³ / ₈