



**XL SERIES
DRYER EXHAUST FANS**

The PWS series is specially designed to exhaust air from the dryer. It has been equipped with a paddle wheel impeller to prevent lint buildup.



ACCESSORIES

Standard:

- Mounting brackets

Optional:

- Lint trap
- Transition



PWS-100 FAN DATA

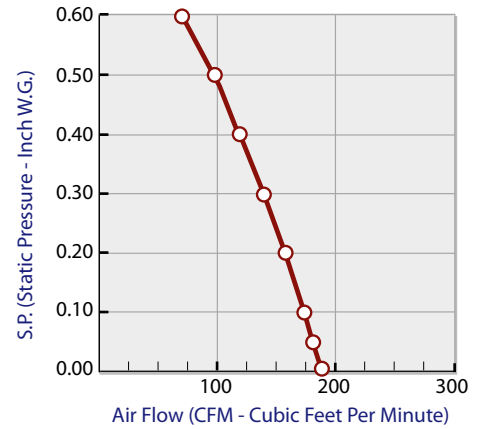

PWS-200 FAN DATA

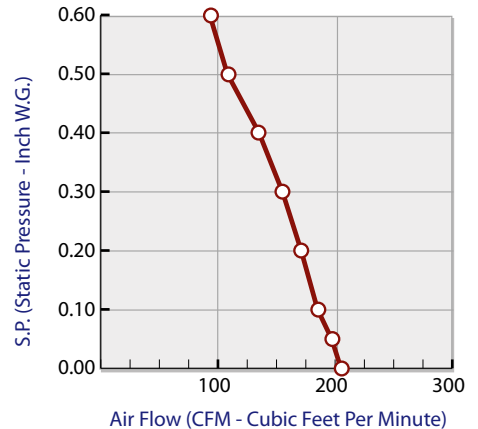

PWS-300 FAN DATA

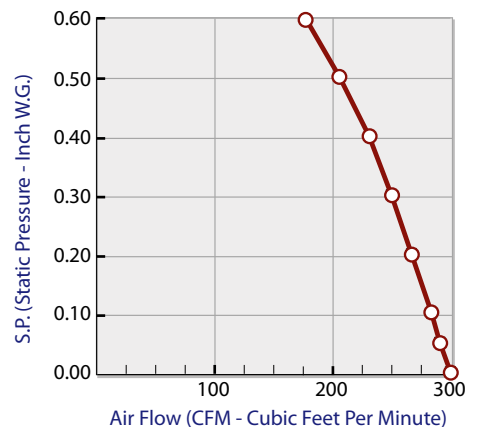

XL SERIES PWS-100, PWS-200, PWS-300

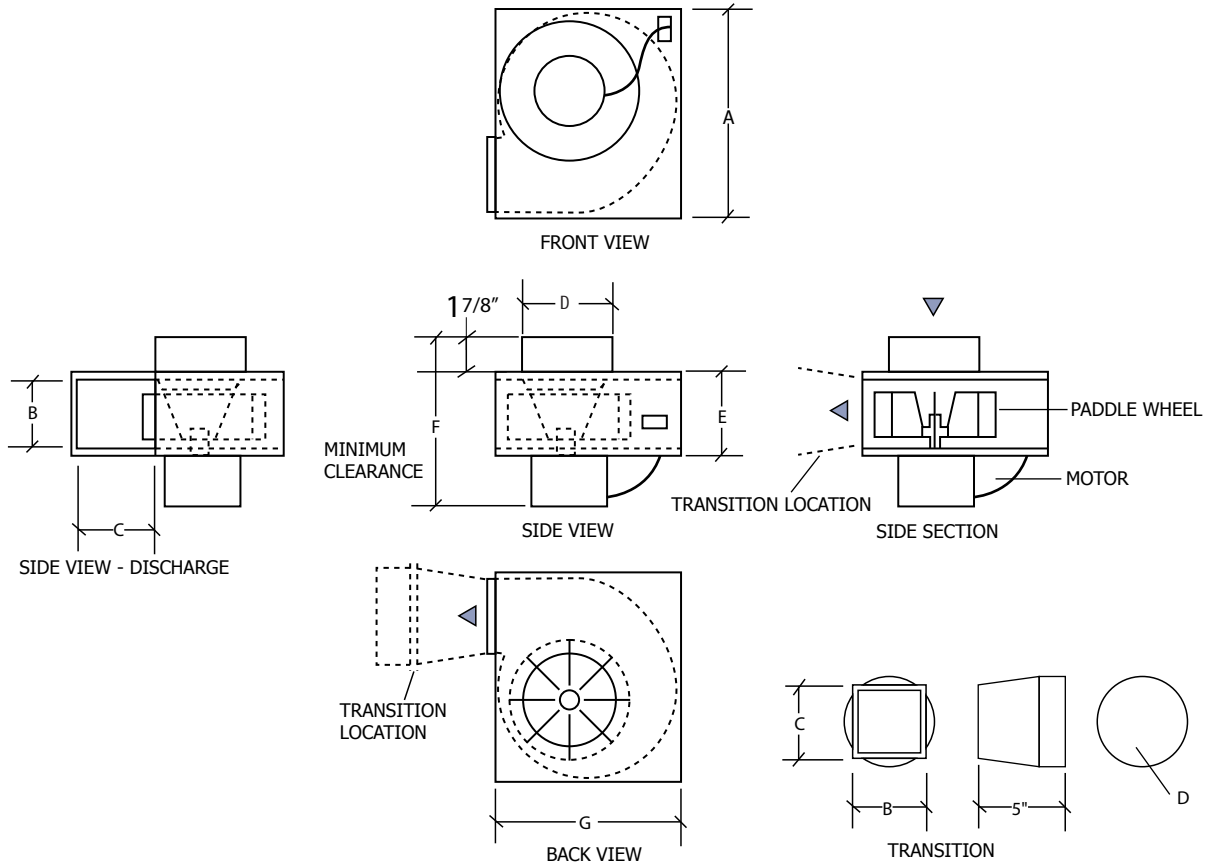

MODEL	A	B	C	D	E	F	G
PWS-100	11	3 ¼	3 ¾	5	4 ½	8 ½	9 ¼
PWS-200	11	3 ¼	3 ¾	6	4 ½	9 ½	9 ¼
PWS-300	12 ¾	4 ½	4 ½	7	5 ½	11	11

All dimensions are shown in inches.

FAN DATA

MODEL	MOTOR 120 VAC 60 Hz		CUBIC FEET PER MINUTE								
	RPM	AMPS	S.P.	0.00	0.05	0.10	0.20	0.30	0.40	0.50	0.60
PWS-100	1550	1.20	CFM	189	181	174	158	140	120	98	74
PWS-200	1550	2.30	CFM	205	197	185	171	155	135	108	93
PWS-300	1550	3.30	CFM	300	291	284	267	250	231	206	177

RPM (Revolution Per Minute) shown is nominal and performance is based on actual speed of test. Units were tested with backdraft damper and outlet duct.

Contractor:		PWS-100, PWS-200, PWS-300		
Architect:	Job:	Date	Supersedes	Drawing NO.
Engineer:	Date Submitted:			

Reversomatic Manufacturing Ltd.

790 Rowntree Dairy Road, Woodbridge, ON Canada L4L 5V3 • Tel: 905-851-6701 • Fax: 905-851-8376
 www.reversomatic.com • info@reversomatic.com