

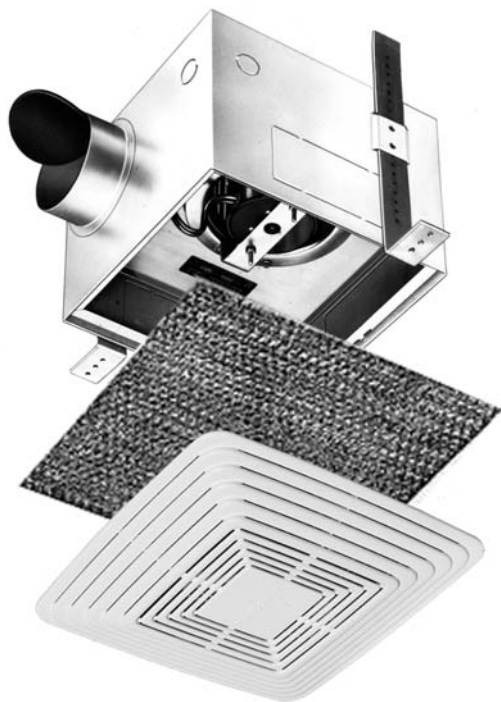

**XL SERIES
BATHROOM AND KITCHEN EXHAUST FAN**

The BK-100 is designed to exhaust one bathroom and one kitchen. However, it can also be used for two bathroom exhaust by eliminating the aluminum mesh washable grease filter. The fan is available with mounting brackets for easy installation. It is also constructed of corrosion resistant heavy gauge satin coat steel.



Plastic Backdraft Damper

IMPORTANT:
Aluminum Mesh Grease Filter is optional & must be installed for kitchen use.

White Aluminum Louvered Grille

BK-100 FAN DATA

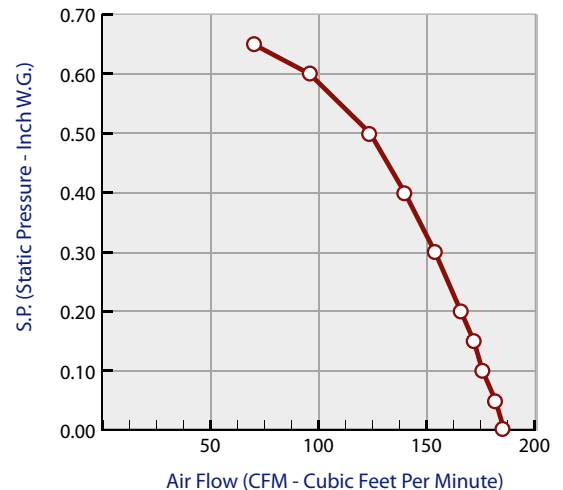

ACCESSORIES

Standard:

- Mounting brackets
- Off white aluminum louvered grille

Optional:

- Balance box
- Variable speed control
- Aluminum backdraft damper
- Aluminum mesh grease filter
- Baffle
- Inline transition



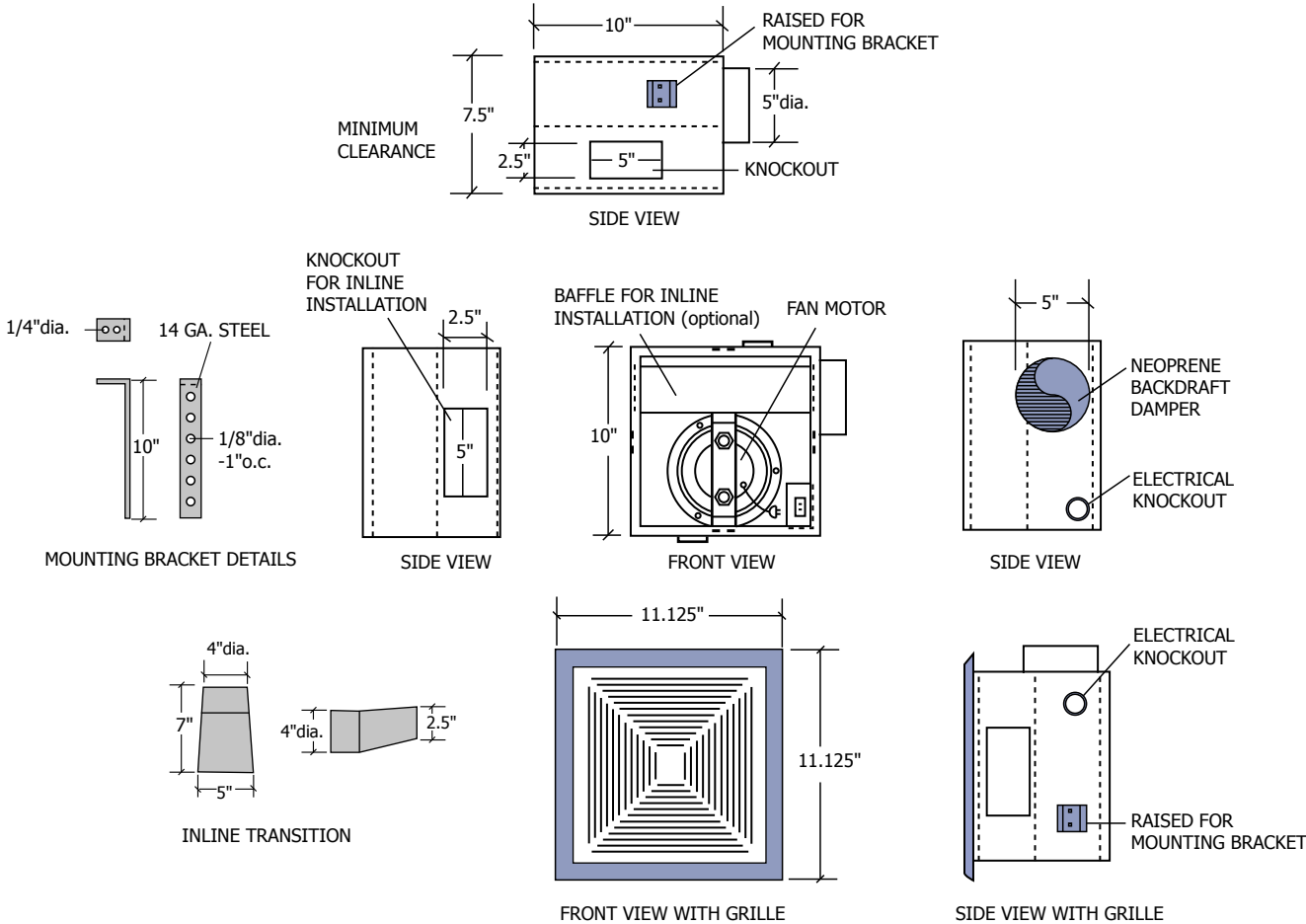

FAN DATA

MODEL	MOTOR 120 VAC 60 Hz		CUBIC FEET PER MINUTE										SONES	
	RPM	AMPS	S.P.	0.00	0.05	0.10	0.15	0.20	0.30	0.40	0.50	0.60		0.65
BK-100	1550	1.4	CFM	186	182	176	172	166	154	140	124	96	70	4.5

RPM (Revolution Per Minute) shown is nominal and performance is based on actual speed of test. Unit was tested with inlet grille, backdraft damper and outlet duct.

SOUND RATING

OCTAVE BAND		1	2	3	4	5	6	7	8
CENTER FREQUENCY Hz		63	125	250	500	1000	2000	4000	8000
STATIC PRESSURE INCH W.G.	0.00	63.3	64.9	61.4	63.8	61.3	56.5	55.1	51.9
	0.34	64.6	66.4	59.2	60.3	56.0	53.1	51.3	47.5
	0.70	72.5	68.4	58.6	59.0	54.1	49.3	45.6	41.8

The sound power level ratings shown are in decibels, referred to 10⁻¹² watts calculated per AMCA Standard 301. Values shown are for inlet Law sound power levels for installation Type B: free inlet, ducted outlet. Ratings do not include the effects of duct end correction.

Contractor:		BK-100 (QB-200 US model)		
Architect:	Job:	Date	Supersedes	Drawing NO.
Engineer:	Date Submitted:			