

GMS8 / GDS8 / GHS8 SERIES 80% AFUE

MULTI-POSITION,
SINGLE-STAGE / MULTI-SPEED
GAS FURNACES

**HEATING CAPACITY:
45,000–140,000 BTUH**



The GMS8/GDS8/GHS8 single-stage, multi-speed gas furnaces offer installation versatility.

Standard Features

- Corrosion-resistant, aluminized-steel tubular heat exchanger
- Designed for multi-position installation—GMS8: upflow, horizontal right or left; GDS8: dedicated downflow; GHS8: high air flow, upflow, horizontal right or left
- Energy-saving, reliable Hot Surface Ignition system, featuring a Norton® Mini-Igniter with patented adaptive learning algorithm
- Aluminized steel inshot burners
- Energy-saving PSC, multi-speed, direct-drive blower motor
- Quiet, corrosion-resistant induced draft blower assembly
- Integrated furnace control with diagnostics
- Low-voltage terminal blocks
- Multiple flame roll-out switches, blower door safety switch, outlet air limit switch and pressure switch for proof of combustion air
- 40VA transformer for heating and air conditioning control service
- Combination redundant gas valve and regulator
- Rotating combustion air blower (GMS8 & GHS8 models) that allows venting through the top, right, or left sides
- Factory run-tested furnace for heating or combination heating/cooling application
- Specified models comply with California NOx Standards

Cabinet Features

- Heavy-gauge, reinforced, fully insulated steel cabinet with durable baked-enamel finish
- Attractive architectural gray paint finish
- Foil-face insulation lines the heat exchanger compartment
- Coil and furnace fit flush for easy installation
- Convenient left or right connection for gas and electric service
- Bottom or side air inlet (GMS8 and GHS8)
- Removable, solid-bottom block off (GMS8 and GHS8)

Accessories

- LP Conversion Kits (LPT-00A)
- High Altitude Natural Gas Kit (HA02)
- Fossil Fuel Kit (FFK03A)
- Downflow Subbase (SBT14, SBT17, SBT21)
- Thermostats (CHT18-60, CH70TG, CHSATG, H20TWR)



PRODUCT SPECIFICATIONS

NOMENCLATURE

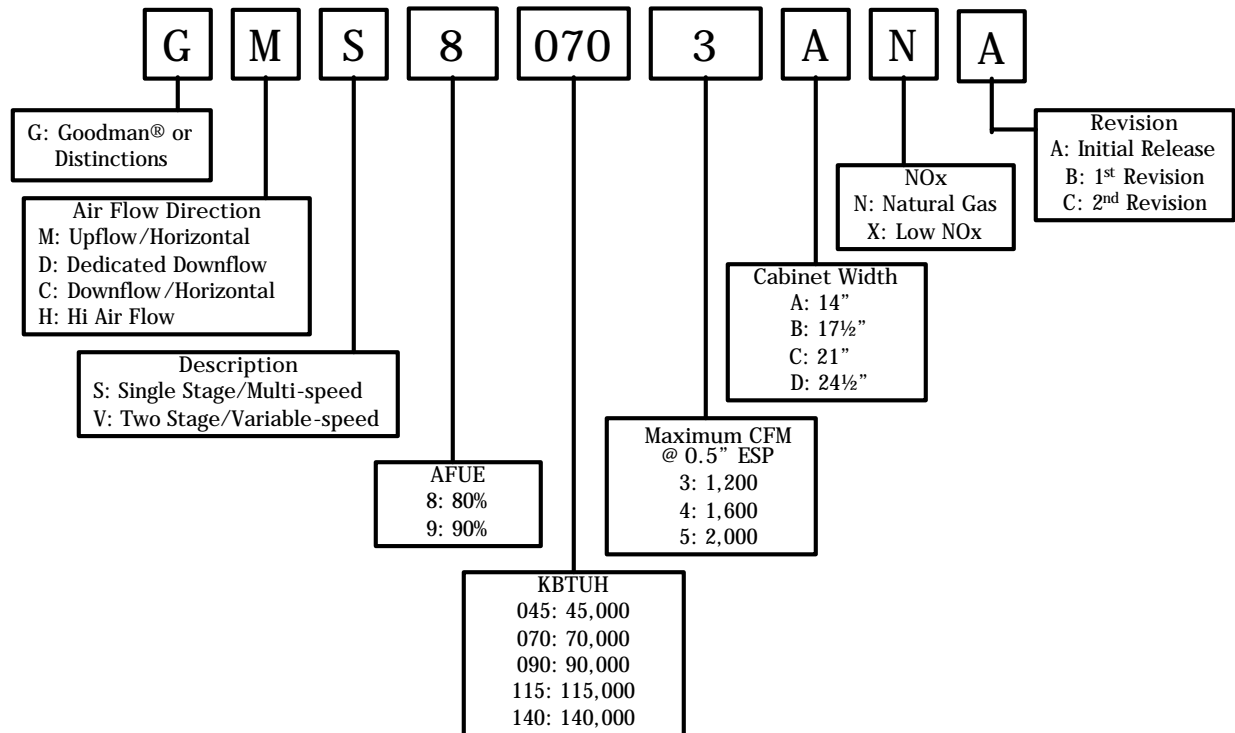

SPECIFICATIONS

Model	Circulator Blower			Vent Diameter ¹	No. of Burners	Filter Size (in ²)		Minimum Circuit Ampacity ²	Max. Overcurrent Protection ³ (amps)	Ship Weight (lbs)
	Size (D x W)	HP	Speed			Perma-ment	Dispos-able			
GMS80453ANA*	10" x 6"	1/3	4	4"	2	290	580	8.1	15	120
GMS80703ANA*	10" x 6"	1/3	4	4"	3	290	580	8.1	15	130
GMS80704BNA*	10" x 8"	1/2	4	4"	3	385	770	12.5	15	143
GMS80903BNA	10" x 8"	1/3	4	4"	4	290	580	8.1	15	153
GMS80904BNA*	10" x 8"	1/2	4	4"	4	385	770	12.5	15	153
GMS80905CNA*	10" x 10"	1/2	4	4"	4	480	960	12.5	15	163
GMS81155CNA*	10" x 10"	1/2	4	4"	5	480	960	12.5	15	163
GMS81405DNA*	10" x 10"	3/4	4	4"	6	480	960	11.8	15	183
GDS80453ANA	10" x 6"	1/3	4	4"	2	290	580	8.1	15	120
GDS80703ANA	10" x 6"	1/3	4	4"	3	290	580	8.1	15	130
GDS80904BNA	10" x 8"	1/2	4	4"	4	385	770	12.5	15	153
GDS81155CNA	10" x 10"	1/2	4	4"	5	480	960	12.5	15	175
GHS80453AXA	10" x 6"	1/2	4	4"	2	290	580	12.5	15	120
GHS80704BXA	10" x 8"	3/4	3	4"	3	385	770	11.8	15	130
GHS80905CXA	11" x 10"	3/4	3	4"	4	480	960	11.8	15	153

* Low NOx model available.

¹ Vent and combustion air diameters may vary depending upon vent length. Refer to the latest editions of the National Fuel Gas Code NFPA 54/ANSI Z223.1 (in the USA) and the Canada National Standard of Canada, CAN/CSA B149.1 and CAN/CSA B142.2 (in Canada).

² Minimum Circuit Ampacity = (1.25 x Circulator Blower Amps) + ID Blower amps.

³ Maximum Overcurrent Protection refers to maximum recommended fuse or circuit breaker size.

NOTES:

- All furnaces are manufactured for use on 115 VAC, 60 Hz, single phase electrical supply.
- Gas Service Connection 1/2" FPT
- Important: It is required to size overcurrent protection device and wires properly and make electrical connections in accordance with the National Electrical Code and/or all existing local codes.

PERFORMANCE RATINGS

Model	Natural Gas Input ¹ BTUH	Output Heating Capacity BTUH		AFUE ²	Tons A/C @ 0.5" ESP ³	Temperature Rise Range (° F)
		Natural	LP			
GMS80453ANA*	45,000	36,000	32,000	80.0	3.0	25 - 55
GMS80703ANA*	70,000	56,000	48,000	80.0	3.0	25 - 55
GMS80704BNA*	70,000	56,000	48,000	80.0	4.0	20 - 50
GMS80903BNA	90,000	72,000	64,000	80.0	3.0	30 - 60
GMS80904BNA*	90,000	72,000	64,000	80.0	4.0	35 - 65
GMS80905CNA*	90,000	72,000	64,000	80.0	5.0	35 - 65
GMS81155CNA*	115,000	92,000	80,000	80.0	5.0	35 - 65
GMS81405DNA*	140,000	112,000	96,000	80.0	5.0	40 - 70
GDS80453ANA	45,000	36,000	32,000	80.0	3.0	20 - 50
GDS80703ANA	70,000	56,000	48,000	80.0	3.0	30 - 60
GDS80904BNA	90,000	72,000	64,000	80.0	4.0	35 - 65
GDS81155CNA	115,000	92,000	80,000	80.0	5.0	40 - 70
GHS80453AXA	45,000	36,000	32,000	80.0	3.0	15 - 45
GHS80704BXA	70,000	56,000	48,000	80.0	4.0	20 - 50
GHS80905CXA	90,000	72,000	64,000	80.0	5.0	35 - 65

* Low NOx model available.

¹ For altitudes above 2,000', reduce input rating 4% for each 1,000' above sea level.

² DOE AFUE based upon Isolated Combustion System (ICS).

³ GHS models rated at 0.8" water column ESP

PRODUCT SPECIFICATIONS

GMS8/GHS8 DIMENSIONS

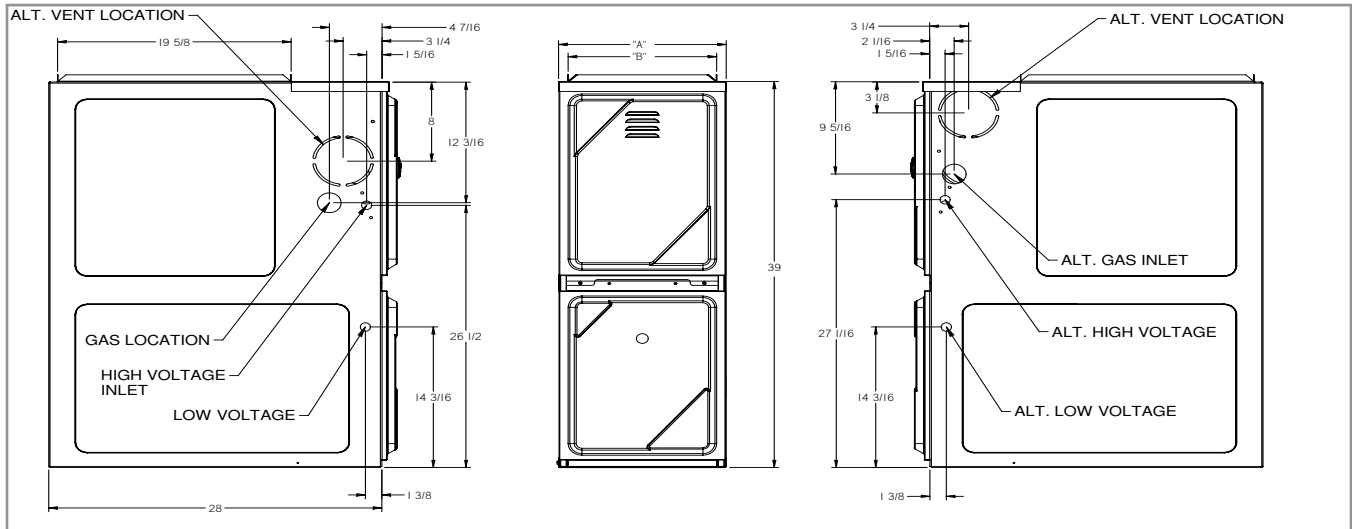

Model	A	B
GMS80453ANA* GMS80703ANA*	14"	12½"
GMS80704BNA* GMS80903BNA GMS80904BNA*	17½"	16"
GMS80905CNA* GMS81155CNA*	21"	19½"
GMS81405DNA*	24½"	23"
GHS80453AXA	14"	12½"
GHS80704BXA	17½"	16"
GHS80905CXA	21"	19½"

* Low NOx model available.

Minimum Clearances to Combustible Materials

Sides	Rear	Front ¹	Vent ²		Top
			SW	B	
1"	0"	3"	6"	1"	1"

NOTE: GMS8 and GHS8 models approved for line contact in the horizontal position.

¹ 36" clearance for serviceability recommended.

² Single Wall Vent (SW) to be used only as a connector. Refer to the latest editions of the National Fuel Gas Code NFPA 54/ ANSI Z223.1 (in the USA) and the Canada National Standard of Canada, CAN/CSA B149.1 and CAN/CSA B142.2 (in Canada).

GDS8 DIMENSIONS

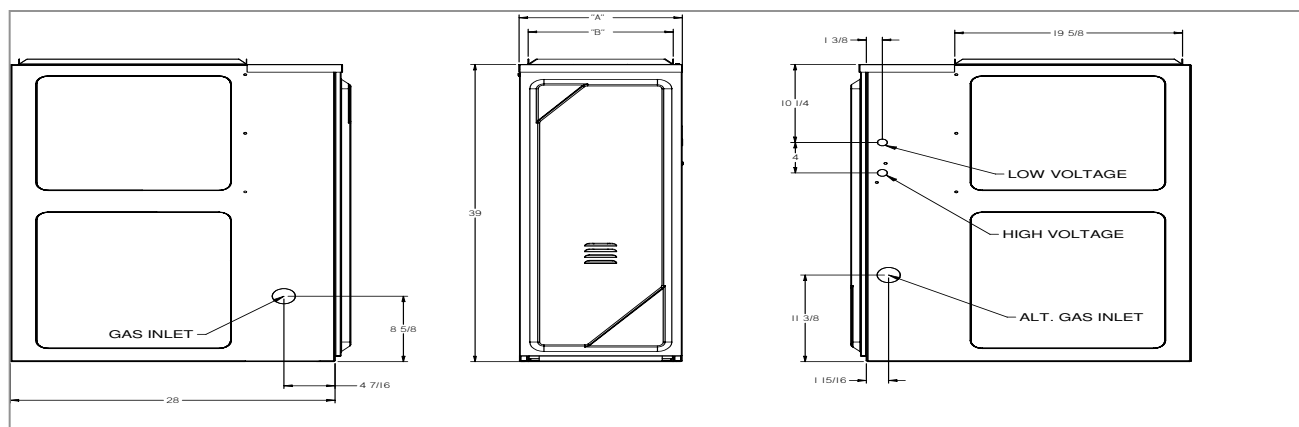

Model	A	B	Non-Combustible Floor Base
GDS80453ANA GDS80703ANA	14"	12½"	SBT14
GDS80904BNA	17½"	16"	SBT17
GDS81155CNA	21"	19½"	SBT21

Minimum Clearances to Combustible Materials

Sides	Rear	Front ¹	Vent ²		Top
			SW	B	
1"	0"	3"	6"	1"	1"

¹ 36" clearance for serviceability recommended.

² Single Wall Vent (SW) to be used only as a connector. Refer to the latest editions of the National Fuel Gas Code NFPA 54/ ANSI Z223.1 (in the USA) and the Canada National Standard of Canada, CAN/CSA B149.1 and CAN/CSA B142.2 (in Canada).

PRODUCT SPECIFICATIONS

BLOWER PERFORMANCE SPECIFICATIONS

Model (Heating Speed As Shipped)	Motor Speed	Tons AC @ 0.5" ESP	CFM & Temperature Rise vs. External Static Pressure (In. W.C.)												
			0.1		0.2		0.3		0.4		0.5		0.6	0.7	0.8
			CFM	Rise	CFM	Rise	CFM	Rise	CFM	Rise	CFM	Rise	CFM	CFM	CFM
GMS80453ANA* (MED-LO)	High	3.0	1,555	---	1,511	---	1,459	---	1,392	---	1,344	25	1,279	1,201	1,120
	Med	2.5	1,165	28	1,123	30	1,100	30	1,090	30	1,048	32	1,017	970	903
	Med-Lo	2.0	927	36	907	37	889	37	863	38	853	39	822	800	746
	Low	1.5	699	47	694	48	668	50	645	51	636	52	592	566	524
GMS80703ANA* (HIGH)	High	3.0	1,437	36	1,310	39	1,295	40	1,310	39	1,273	41	1,202	1,129	1,039
	Med	2.5	1,127	46	1,100	47	1,095	47	1,075	48	1,050	49	1,018	967	904
	Med-Lo	2.0	895	---	917	---	878	---	867	---	853	---	830	786	743
	Low	1.5	694	---	681	---	663	---	640	---	625	---	591	562	522
GMS80704BNA* (MED-LO)	High	4.0	2,234	23	2,151	24	2,076	25	1,990	26	1,897	27	1,803	1,710	1,569
	Med	3.5	1,676	31	1,653	31	1,648	31	1,581	33	1,555	33	1,492	1,414	1,352
	Med-Lo	3.0	1,342	38	1,335	39	1,321	39	1,313	39	1,291	40	1,261	1,215	1,149
	Low	2.5	1,089	47	1,085	48	1,078	48	1,071	48	1,057	49	1,040	986	932
GMS80903BNA (HIGH)	High	3.0	1,593	42	1,561	43	1,567	42	1,543	43	1,493	44	1,420	1,343	1,230
	Med	2.5	1,186	56	1,160	57	1,160	57	1,135	58	1,118	59	1,089	1,045	983
	Med-Lo	2.0	957	---	940	---	937	---	921	---	895	---	861	826	778
	Low	1.5	742	---	710	---	685	---	663	---	635	---	611	578	476
GMS80904BNA* (MED-LO)	High	4.0	2,182	---	2,127	31	2,056	32	1,974	33	1,895	35	1,809	1,715	1,588
	Med	3.5	1,645	40	1,628	40	1,615	40	1,597	41	1,541	43	1,491	1,440	1,350
	Med-Lo	3.0	1,320	49	1,305	49	1,310	49	1,310	50	1,295	51	1,267	1,217	1,139
	Low	2.5	1,063	60	1,061	60	1,057	61	1,056	61	1,039	61	1,025	1,005	948
GMS80905CNA* (MED-LO)	High	5.0	2,334	---	2,334	---	2,284	---	2,135	---	2,051	35	1,910	1,748	1,605
	Med	4.0	1,754	39	1,735	39	1,728	40	1,685	40	1,628	42	1,551	1,469	1,346
	Med-Lo	3.5	1,367	47	1,380	47	1,371	47	1,374	48	1,335	50	1,293	1,246	1,165
	Low	3.0	1,098	58	1,109	59	1,109	59	1,088	60	1,066	62	1,050	998	916
GMS81155CNA* (MED)	High	5.0	2,481	---	2,395	35	2,288	37	2,217	38	2,076	41	1,999	1,858	1,732
	Med	4.0	1,738	49	1,732	49	1,709	50	1,686	50	1,639	52	1,585	1,492	1,385
	Med-Lo	3.5	1,364	62	1,378	62	1,372	62	1,372	62	1,350	63	1,313	1,261	1,125
	Low	3.0	1,137	---	1,142	---	1,140	---	1,114	---	1,090	---	1,056	954	860
GMS81405DNA* (MED)	High	5.0	2,554	41	2,435	43	2,375	44	2,240	47	2,152	49	2,002	1,883	1,744
	Med	4.0	1,846	57	1,773	59	1,762	60	1,712	61	1,672	63	1,583	1,526	1,442
	Med-Lo	3.5	1,520	69	1,500	70	1,483	---	1,470	---	1,435	---	1,373	1,308	1,245
	Low	3.0	1,301	---	1,274	---	1,260	---	1,231	---	1,207	---	1,177	1,093	931

* Low NOx model available.

BLOWER PERFORMANCE SPECIFICATIONS (CONT.)

Model (Heating Speed As Shipped)	Motor Speed	Tons AC @ 0.5" ESP	CFM & Temperature Rise vs. External Static Pressure (In. W.C.)															
			0.1		0.2		0.3		0.4		0.5		0.6		0.7		0.8	
			CFM	Rise	CFM	Rise	CFM	Rise	CFM	Rise	CFM	Rise	CFM	Rise	CFM	CFM	CFM	
GDS80453ANA (MED-LO)	High	3.0	1,435	---	1,421	---	1,380	---	1,322	25	1,262	26	1,200	1,144	1,064			
	Med	2.5	1,140	29	1,114	30	1,084	31	1,063	31	1,039	32	1,002	943	897			
	Med-Lo	2.0	899	37	889	37	875	38	871	38	857	39	821	780	745			
	Low	1.5	691	48	674	49	665	50	651	51	637	52	618	562	525			
GDS80703ANA (MED)	High	3.0	1,406	37	1,393	37	1,379	37	1,307	39	1,262	41	1,208	1,145	1,070			
	Med	2.5	1,153	45	1,101	47	1,077	48	1,039	50	1,028	50	987	947	885			
	Med-Lo	2.0	890	58	896	58	873	59	862	60	834	---	798	771	727			
	Low	1.5	690	---	682	---	664	---	631	---	616	---	583	549	509			
GDS80904BNA (MED-LO)	High	4.0	2,007	---	1,993	---	1,975	---	1,940	---	1,844	36	1,770	1,668	1,559			
	Med	3.5	1,612	41	1,606	41	1,570	42	1,533	43	1,501	44	1,448	1,373	1,301			
	Med-Lo	3.0	1,325	50	1,299	51	1,280	52	1,244	53	1,222	54	1,186	1,140	1,079			
	Low	2.5	1,043	64	1,040	64	1,032	64	1,002	---	981	---	955	915	869			
GDS81155CNA (MED)	High	5.0	2,381	---	2,312	---	2,312	---	2,219	---	2,134	40	2,024	1,930	1,839			
	Med	4.0	1,801	47	1,667	51	1,667	51	1,638	52	1,613	53	1,513	1,441	1,369			
	Med-Lo	3.5	969	---	1,062	---	1,140	---	1,223	69	1,269	67	1,292	1,322	1,358			
	Low	3.0	1,100	---	1,094	---	1,060	---	1,031	---	1,001	---	953	937	874			

Model (Heating Speed as Shipped)	Motor Speed	Tons AC @ 0.5" ESP	CFM & Temperature Rise vs. External Static Pressure (In. W.C.)															
			0.01		0.02		0.03		0.04		0.05		0.06		0.07		0.08	
			CFM	Rise	CFM	Rise	CFM	Rise	CFM	Rise	CFM	Rise	CFM	Rise	CFM	Rise	CFM	Rise
GHS80453AXA (Low)	High	3.0	1,654	---	1,647	---	1,605	---	1,537	---	1,499	---	1,493	---	1,406	---	1,307	25
	Med	2.5	1,489	---	1,463	---	1,456	---	1,416	---	1,403	---	1,346	25	1,271	26	1,185	28
	Med-Low	2.0	1,349	25	1,282	26	1,246	27	1,235	27	1,218	27	1,187	28	1,128	29	1,051	32
	Low	1.5	1,088	30	1,086	31	1,082	31	1,069	31	1,045	32	1,013	33	968	34	908	37
GHS80704BXA (Med)	High	4.0	2040	25	1991	26	1942	27	1912	27	1891	27	1850	28	1828	28	1785	29
	Med	3.5	1563	33	1527	34	1490	35	1461	35	1444	36	1423	36	1401	37	1370	38
	Low	3.0	1165	44	1149	45	1133	46	1122	46	1111	46	1089	47	1048	49	994	52
GHS80905CXA (Med)	High	5.0	2,402	---	2,321	---	2,265	---	2,193	---	2,134	---	2,057	---	1,962	---	1,895	35
	Med	4.0	1,754	38	1,718	39	1,661	40	1,622	41	1,581	42	1,519	44	1,433	46	1,387	48
	Low	3.5	1,266	52	1,234	54	1,177	56	1,143	58	1,071	62	1,024	65	964	---	878	---

NOTES:

1. CFM in chart is without filter(s). Filters do not ship with this furnace, but must be provided by the installer.
2. All furnaces ship as high speed cooling. Installer must adjust blower cooling speed as needed.
3. For most jobs, about 400 CFM per ton when cooling is desirable.
4. INSTALLATION IS TO BE ADJUSTED TO OBTAIN TEMPERATURE RISE WITHIN THE RANGE SPECIFIED ON THE RATING PLATE.
5. The chart is for information only. For satisfactory operation, external static pressure must not exceed value shown on the rating plate. The shaded area indicates ranges in excess of maximum static pressure allowed when heating.
6. The dashed (---) areas indicate a temperature rise not recommended for this model.
7. The above chart is for U.S. furnaces installed at 0' - 2,000'. At higher altitudes, a properly de-rated unit will have approximately the same temperature rise at a particular CFM, while ESP at the CFM will be lower.

PRODUCT SPECIFICATIONS

ACCESSORIES

Model	Description	GMS80453ANA*	GMS80703ANA*	GMS80704BNA*	GMS80903BNA	GMS80904BNA*	GMS80905CNA*	GMS81155CNA*	GMS81405DNA*	GDS80453ANA	GDS80703ANA	GDS80904BNA	GDS81155CNA	GHS80453AXA	GHS80704BXA	GHS80905CXA
LPT-00A	Propane (LP) Conversion Kit	√	√	√	√	√	√	√	√	√	√	√	√	√	√	√
HA02	High Altitude Natural Gas Kit	√	√	√	√	√	√	√	√	√	√	√	√	√	√	√
FFK03A	Fossil Fuel Kit	√	√	√	√	√	√	√	√	√	√	√	√	√	√	√
SBT14	Downflow Subbase for 14" Furnace									√	√					
SBT17	Downflow Subbase for 17½" Furnace											√				
SBT21	Downflow Subbase for 21" Furnace												√			

* Low NOx model available.

THERMOSTATS

Model	Description
CHT18-60	Cooling/Heating, Mechanical
CH70TG	Cooling/Heating, Digital, Non-programmable
CHSATG	Cooling/Heating, Mechanical
H20TWR	Heating Only, Mechanical



Air Conditioning & Heating

Goodman Manufacturing Co., L.P., reserves the right to discontinue, or change at any time, specifications or designs without notice or without incurring obligations.

Copyright © 2005 Goodman Manufacturing Co, L.P. • Houston, Texas
 Goodman® brand products are made proudly in the USA. Printed in the USA.