

REZNOR®

MODEL WS

**INDOOR, SUSPENDED,
STEAM OR HOT WATER
HYDRONIC UNIT HEATER
FOR VERTICAL OR HORIZONTAL
CONFIGURATION**



DESCRIPTION

Reznor® Model WS Steam/Hot Water Suspended Heaters are design-engineered to be technically advanced and esthetically pleasing which makes it the hydronic heater for the 21st century.

This smart new concept in commercial heating units will accommodate all architects who are looking for something new and different.

The heating range of Model WS is 13,000 to 350,000 BTUH. The air volume ranges from 270 to 4,750 CFM.

The heat exchanger is made of one or two rows of copper coils with aluminum fins, with approximately 10-1/2 fins per inch (4 fins per cm). The spacing between the fins makes cleaning and maintenance of the heat exchanger easier, which is essential to keep the unit heater efficient.

The copper tubing used for the heating coil is very thick (0.03", 0.75 mm), making Reznor heating coils extremely sturdy and long lasting.

The copper tube diameter is 0.867" (22 mm) O.D. The large tube diameter reduces the water pressure drop, which means these units require lower pump pressure than other hydronic heaters. It also allows a very rapid heat radiation.

The heat exchanger assembly receives a special paint coating which makes the coil long lasting and increases the thermal output.

Reznor® Model WS can be used with a high working pressure with hot water up to 150 psi and with steam up to 145 psi (10 bar). Every heat exchanger is subjected to a pressure test at over 350 psi (25 bar) before leaving the factory.

The Fan/Motor Assembly is made up of three components: the fan, the motor and the fan guard, which also acts as the main support for the fan. This fan guard is galvanized for protection against corrosion, and is mounted onto the main casing with anti-vibration rubber mountings.

The standard 2-speed motor is a hermetically sealed motor which is maintenance free. The motor is wired for 115/1/60 supply voltage. The motor speed is field adjustable to run at high or low RPMs. Refer to the Technical Data Chart for fan RPM, heating output and CFM ranges.

The flexibility of changing motor speeds allows the installer to adjust the unit to high speed for increased BTUH output, or low speed for reduced noise level. All motors have internal protection as a standard feature.

All Model WS units can be installed for either vertical or horizontal discharge.

The unit cabinet is manufactured from .032" (0.8mm) galvanized pre-painted steel finished in dove gray. Using pre-painted steel helps protect the cabinet against oxidation.

The cabinet is held together by shake-proof screws and molded corner sections to add additional strength and durability. Adjustable louvers are held in place by spring loaded pivots. Vertical louvers are available for field installation.

Optional overhead door diffusers are available on size 300/350. This option allows the unit to be installed over loading dock doors maintaining a warm air curtain where it is needed most.

The optional Air Flow Induction Optimizer is available for horizontally discharged units. The Air Flow Induction Optimizer increases the air flow due to the unique shape of its deflecting louvers which improves the throw of the heated air stream. See the optional accessories section for more information.

Units are packaged into strong corrugated cardboard cartons with strengthened upper and lower side sections. These containers are clearly marked with the model number, size and approximate shipping weight.

Units are manufactured in an ISO 9001 registered facility.

STANDARD FEATURES

- Heat exchanger composed of 0.03" thick, .867" O.D copper tubes and aluminum fins spaced approximately 10-1/2 fins per inch
- Painted copper tubing heat exchanger and aluminum fins
- Either steam or hot water heating source
- Fan/Motor Assembly includes galvanized fan guard
- Vertical or horizontal configuration
- Cabinet and louvers constructed of galvanized pre-painted steel
- Cabinet held together by shake-proof screws and molded corner sections
- Spring mounted horizontal louvers
- 115/60 single phase, two speed motor (field adjustable)
- Manufactured in an ISO 9001 registered facility

FIELD INSTALLED OPTIONS

- Vertical louvers for better air distribution - vertical or horizontal discharge
- Door air curtain adapter for size 300/350 -vertical discharge
- Air flow induction louvers increase air flow and throw - horizontal discharge
- Overhead door switch
- Light duty, or heavy duty thermostat
- Thermostat guard cover
- Two speed fan switch

TECHNICAL DATA

		Fan Speed	Size								
			18/24	23/33	44/62	60/85	78/110	96/120	140/175	190/238	300/350
Maximum Heating Capacity ^A	MBH	Low	18	23	44	60	78	96	140	190	300
		High	24	33	62	85	110	120	175	238	350
	Watts	Low	5,276	6,741	12,896	17,586	22,862	28,138	41,034	55,689	87,930
		High	7,034	9,672	18,172	24,914	32,241	35,172	51,293	69,758	102,585
	kcal/hr	Low	4,536	5,796	11,089	15,121	19,657	24,194	35,282	47,883	75,605
		High	6,048	8,317	15,625	21,421	27,722	30,242	44,103	59,980	88,206
Maximum Leaving Air Temperature (L.A.T.) ^B	°F	Low	121°	124°	132°	129°	125°	134°	134°	140°	133°
		High	115°	121°	126°	123°	121°	131°	130°	137°	128°
	°C	Low	49°	51°	56°	54°	52°	57°	57°	62°	56°
		High	46°	49°	52°	51°	49°	55°	54°	58°	53°
Approximate Fan RPM	Low	1,100	1,100	1,100	1,100	1,100	850	850	850	850	
	High	1,550	1,600	1,600	1,600	1,600	1,080	1,080	1,080	1,080	
Motor HP 115/1/60 Motor	Low	0.014	0.020	0.027	0.048	0.090	0.041	0.070	0.110	0.500	
	High	0.040	0.055	0.082	0.150	0.260	0.090	0.160	0.250	1.140	
Amp Rating 115/1/60 Motor	Low	0.3	0.4	0.6	1.1	1.7	0.9	1.1	2.2	6.5	
	High	0.6	0.9	1.2	1.9	3.0	1.8	2.6	3.4	13.0	
Noise Level at 16-1/2 ft (5m) - dB(A)	Low	45	46	49	54	57	47	49	52	61	
	High	52	54	58	63	65	52	55	60	67	
Approximate Air Volume	cfm	Low	270	330	560	800	1,100	1,200	1,750	2,200	3,800
		High	400	500	860	1,250	1,650	1,550	2,300	2,850	4,750
	m ³ /hr	Low	459	561	952	1,359	1,869	2,039	2,973	3,738	6,457
		High	680	850	1,461	2,124	2,804	2,634	3,908	4,842	8,071
Supply Air Velocity	fpm	Low	382	443	522	549	578	500	590	613	755
		High	540	672	802	860	866	642	773	793	936
	m/min	Low	116	135	159	167	176	152	180	187	230
		High	165	205	244	262	264	196	236	242	285
Rows of Coils in Heat Exchanger			1	2	2	2	2	2	2	2	
Water Content	Gallons		1/4	1/2	11/16	7/8	1	1 3/16	1 9/16	1 7/8	2 15/16
	Liters		1.0	2.0	2.6	3.2	3.8	4.6	6.0	7.0	11.1
Approximate Weight	lbs.		37	44	49	55	66	75	88	101	146
	Kg		17	20	22	25	30	34	40	46	66

^A Maximum heating capacity based on steam pressure at 2 psi with entering air temperature of 60°F (16°C) See tables on page 4 for more information.

^B Based on an entering air temperature of 60°F (16°C).

DIMENSIONS ACCURATE WITHIN ±1/8" (±3mm)

Size	A	B	C	D	E	F	G	Fan Diameter	Ø
18/24	16-7/16 (418)	11-1/8 (282)	18-5/16 (465)	12-5/8 (321)	8-11/16 (220)	5-1/8 (130)	3-15/16 (100)	11-13/16 (300)	3/4
23/33	16-7/16 (418)	11-1/8 (282)	18-5/16 (465)	12-5/8 (321)	8-11/16 (220)	5-1/8 (130)	3-15/16 (100)	11-13/16 (300)	3/4
44/62	18-9/16 (472)	13-1/4 (336)	18-5/16 (465)	14-3/4 (375)	8-11/16 (220)	5-1/8 (130)	3-15/16 (100)	13-3/4 (350)	1 1/4
60/85	20-11/16 (526)	15-3/8 (390)	18-5/16 (465)	16-7/8 (429)	8-11/16 (220)	5-1/8 (130)	3-15/16 (100)	15-3/4 (400)	1 1/4
78/110	22-13/16 (580)	17-1/2 (444)	18-5/16 (465)	19 (483)	8-11/16 (220)	5-1/8 (130)	4-3/4 (120)	17-11/16 (450)	1 1/4
96/120	24-15/16 (634)	19-5/8 (498)	19-3/16 (488)	21-1/8 (537)	8-11/16 (220)	5-1/8 (130)	4-3/4 (120)	17-11/16 (450)	1 1/4
140/175	27-1/16 (688)	21-3/4 (552)	19-3/16 (488)	23-1/4 (591)	8-11/16 (220)	5-1/8 (130)	4-3/4 (120)	19-11/16 (500)	1 1/4
190/238	29-3/16 (742)	23-7/8 (606)	20-3/16 (513)	25-3/8 (645)	8-11/16 (220)	5-1/8 (130)	5-1/8 (130)	21-5/8 (550)	1 1/4
300/350	35-7/16 (900)	30-1/16 (764)	22-5/8 (575)	31-5/8 (803)	8-1/4 (210)	5-1/2 (140)	5-1/8 (130)	25-9/16 (650)	1 1/2

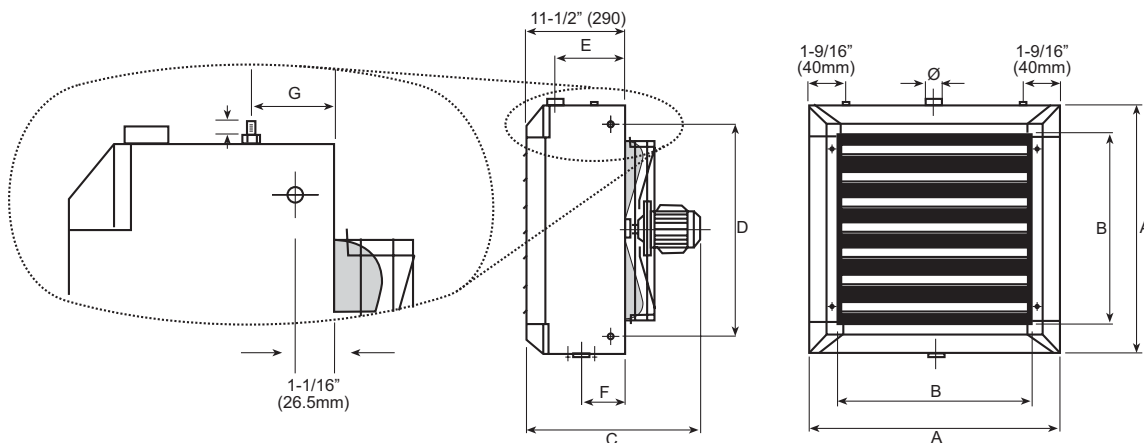

RZ-NA-C-HU Page 3