

PACKAGED GAS/ELECTRIC

PRODUCT SPECIFICATIONS



15 SEER
80% AFUE

2, 3, 4, & 5 Ton
SINGLE-PHASE

COOLING CAPACITY:
23,200 – 56,500 BTU/H

HEATING CAPACITY:
69,000 – 138,000 BTU/H



The Amana® brand APG15 packaged gas/electric unit uses the environmentally friendly refrigerant R-410A and provides high-efficiency performance at reasonable operating costs. This unit is housed in a heavy-gauge, zinc-coated steel cabinet with a weather-resistant, powder-paint finish and allows for a ground-level or rooftop mount, horizontal or downflow application.

Standard Features

- Patented, heavy-duty Million-Air™ stainless-steel heat exchanger for maximum efficiency
- High-efficiency compressor with factory-installed sound blanket; two-stage compressor on 3-, 4-, and 5-ton models
- EEM (energy-efficient) blower motor
- Fully charged R-410A system
- Copper tube, aluminum fin coils with TXV expansion device
- Redundant two-stage gas valve; natural gas with easy conversion to propane
- Power-assisted combustion
- Direct-spark ignition system, including a microprocessor-based control for the entire ignition sequence
- All blower operation and all safety circuits complete with self-diagnostics
- Loss-of-charge protection and high-pressure switch
- California Low NOx approved



Cabinet Features

- Fully insulated heavy-gauge, zinc-coated steel cabinet with UV-resistant powder-paint finish
- Compressor grommets for vibration isolation
- All models fit in a standard-size pick-up truck
- One roof curb fits all units
- Convenient access panels
- Bottom 2" high base rails for easier handling

Contents

Nomenclature.....	2
Product Specifications	3
Evaporator Blower Specifications.....	4
Expanded Cooling Data.....	6
Dimensions.....	20
Wiring Diagrams	21
Accessories	23

NOMENCLATURE

	A	P	G	13	36	045	4	1	
	1	2	3	4,5	6,7	8,9,10	11	12	
Brand	A Amana® Brand							Electrical	
								1	208-230/1/60
								3	208-230/3/60
Product Category	P Packaged Unit							Refrigerant	
								2	R-22
								4	R-410A
Unit Type	G Gas/Electric							Heat Input	
								45	46 MBTU/h
								70	69 MBTU/h
								90	92 MBTU/h
								115	115 MBTU/h
								140	138 MBTU/h
Efficiency	13 13 SEER 15 15 SEER								
Nominal Capacity	24 2 Tons 42 3½ Tons 30 2½ tons 48 4 Tons 36 3 Tons 60 5 Tons								

Important EnergyStar Notice: Proper sizing and installation of equipment is critical to achieve optimal performance. Split system air conditioners and heat pumps must be matched with appropriate coil components to meet EnergyStar criteria. Ask your contractor for details or visit www.energystar.gov.

SPECIFICATIONS

	APG15 2407041**	APG15 3609041**	APG15 4811541**	APG15 6014041**
Cooling Capacity (BTU/h)				
Total ^{2 3}	23,200	35,400	47,500	56,500
Sensible ^{2 3}	18,500	27,500	37,000	44,000
EER ^{2 3}	12.0	11	11	10.1
Total ^{2 4}	N/A	38,500	52,000	62,000
EER ^{1 4} / SEER	N/A / 15.0	15.8 / 15.0	15.5 / 15.0	14.4 / 14.0
Decibels	76.0	76.0	78.0	78.0
Heating Capacity (BTU/h)				
Input ²	69,000	92,000	115,000	138,000
Output ²	55,000	72,900	91,200	110,200
AFUE	80.0	80.0	80.0	80.0
Temperature Rise Range	35 - 65	45 - 75	45 - 75	45 - 75
No. of Burners	3.0	4.0	5.0	6.0
Orifice Size (Natural/Propane)	43 / 55	43 / 55	43 / 55	43 / 55
Input ¹	51,500	69,000	86,000	103,500
Output ¹	40,500	54,500	68,000	82,000
Evaporator Motor				
Type	X-13	X-13	X-13	X-13
Wheel (DxW)	10" x 8"	10" x 9"	11" x 10"	11" x 10"
Indoor Nominal CFM	845	800 / 1,225	1,100 / 1,510	1,300 / 1,810
Motor Speed Tap (Cooling)	T4	T3, T4	T3, T4	T3, T4
RPM / Amps (Cooling)	724 / 1.21	640 / 0.98; 960 / 3.06	647 / 1.66; 890 / 3.80	778 / 1.98; 1,030 / 5.7
Horsepower-RPM	½ / 1,050	½ / 1,050	¾ / 1,050	1 / 1,050
Evaporator Coil				
Face Area (ft ²)	4.33	4.33	5.67	5.67
Rows Deep / Fin per Inch	2 / 14	4 / 14	4 / 14	4 / 14
Expansion Device	TXV	TXV	TXV	TXV
Filter Size (ft ²)	2.7	4.2	5.1	6.3
Drain Size (NPT)	¾"	¾"	¾"	¾"
Refrigerant Charge (oz.)	84	102	172	180
Condenser Fan				
Horsepower - RPM	1/6 - 850	¼ - 1,075	½ - 1,075	½ - 1,075
Fan Diameter / # of Fan Blades	22" / 3	22" / 3	22" / 4	22" / 4
Outdoor Nominal CFM	2,400	2,700	3,500	3,500
Condenser Coil				
Face Area (ft ²)	12.3	12.3	15.3	15.3
Row Deep / Fins per Inch	1 / 22	1 / 22	2 / 16	2 / 16
Electrical Data				
Voltage/ Phase/ Frequency	208-230/ 1/ 60	208-230/ 1/ 60	208-230/ 1/ 60	208-230/ 1/ 60
Compressor RLA / LRA	13.5 / 58.3	16.7 / 82	21.2 / 96	25.8 / 118
Indoor Blower FLA	4.1	4.1	6.0	7.6
Outdoor Fan FLA / LRA	1.1 / 1.7	1.4 / 2.9	2.4 / 5.2	2.4 / 5.2
Total Unit Amps	9.0	15.9	20.1	26.8
Min. Circuit Ampacity	22.1	26.5	34.8	42.1
Max. Overcurrent Protection	30	40	50	60
Entrance Size Power Supply	1½"	1½"	1½"	1½"
Entrance Size Control Voltage	¾"	¾"	¾"	¾"
Operating Weight (lbs)				
	417	458	538	543
Ship Weight (lbs)				
	439	480	560	565

¹ Single Stage

² Two Stage (or Single Stage 2-ton only)

³ Outdoor Ambient Temperature @ 95°F

⁴ Outdoor Ambient Temperature @ 82°F

Note: Always check the S&R plate for electrical data on the unit being installed.

EVAPORATOR BLOWER SPECIFICATIONS

APG15 - 2-Ton Models

Motor Speed	T1				T2				T3				T4				T5			
	E.S.P	CFM	Watts	RPM	Amps	CFM	Watts	RPM	Amps	CFM	Watts	RPM	Amps	CFM	Watts	RPM	Amps	CFM	Watts	RPM
0.1	742	84	600	0.75	907	134	678	1.18	857	116	656	1.04	907	134	678	1.18	1040	185	760	1.33
0.2	677	89	649	0.82	857	140	723	1.24	816	126	704	1.16	857	140	723	1.24	988	198	800	1.40
0.3	631	97	698	0.90	814	149	773	1.32	760	131	745	1.18	814	149	773	1.32	949	208	838	1.42
0.4	575	101	749	0.92	761	154	815	1.33	721	140	790	1.25	761	154	815	1.33	903	213	872	1.49
0.5	526	111	788	1.01	727	165	860	1.41	670	145	836	1.31	727	165	860	1.41	871	222	916	1.55
0.6	-	-	-	-	678	169	898	1.47	629	155	884	1.39	678	169	898	1.47	824	228	948	1.58
0.7	-	-	-	-	-	-	-	-	-	-	-	-	-	-	-	-	-	-	-	-
0.8	-	-	-	-	-	-	-	-	-	-	-	-	-	-	-	-	-	-	-	-

APG15 - 3-Ton Models

Motor Speed	T1				T2				T3				T4				T5			
	E.S.P	CFM	Watts	RPM	Amps	CFM	Watts	RPM	Amps	CFM	Watts	RPM	Amps	CFM	Watts	RPM	Amps	CFM	Watts	RPM
0.1	1065	168	758	1.42	1255	257	859	2.10	924	120	692	1.08	1333	304	900	2.41	1418	360	944	2.92
0.2	1003	174	796	1.48	1217	269	893	2.19	863	128	734	1.14	1293	314	934	2.48	1375	371	978	3.00
0.3	961	185	841	1.55	1165	274	928	2.21	812	138	783	1.24	1237	321	963	2.54	1316	376	1007	3.05
0.4	913	195	888	1.62	1113	285	971	2.30	745	145	839	1.27	1193	333	1010	2.71	1279	387	1037	3.13
0.5	855	202	938	1.69	1073	296	1006	2.36	702	154	889	1.35	1158	341	1035	2.77	1245	392	1069	3.19
0.6	814	212	977	1.76	1018	302	1044	2.41	643	159	933	1.37	1101	345	1071	2.78	1193	400	1099	3.22
0.7	749	218	1018	1.82	991	313	1081	2.48	601	168	978	1.44	-	-	-	-	-	-	-	-
0.8	713	227	1059	1.87	-	-	-	-	502	173	1025	1.52	-	-	-	-	-	-	-	-

APG15 - 4-Ton Models

Motor Speed	T1				T2				T3				T4				T5			
	E.S.P	CFM	Watts	RPM	Amps	CFM	Watts	RPM	Amps	CFM	Watts	RPM	Amps	CFM	Watts	RPM	Amps	CFM	Watts	RPM
0.1	1140	178	642	1.52	1417	305	755	2.46	1140	178	642	1.52	1616	436	840	3.34	1696	503	876	4.04
0.2	1090	188	682	1.57	1374	318	786	2.56	1090	188	682	1.57	1573	449	867	3.46	1650	517	901	4.15
0.3	1038	199	718	1.67	1322	327	816	2.68	1038	199	718	1.67	1527	462	893	3.59	1608	530	926	4.25
0.4	980	212	758	1.76	1273	338	846	2.72	980	212	758	1.76	1485	474	921	3.69	1566	543	954	4.39
0.5	914	220	796	1.79	1224	352	877	2.82	914	220	796	1.79	1443	489	948	3.8	1523	556	978	4.43
0.6	852	231	837	1.9	1176	365	910	2.88	852	231	837	1.9	1399	502	976	3.86	1480	569	1002	4.55
0.7	806	242	871	1.97	1121	379	946	2.93	806	242	871	1.97	1356	513	1002	3.99	1441	580	1028	4.65
0.8	741	248	906	2.01	1068	391	980	2.98	741	248	906	2.01	1307	525	1031	4.05	-	-	-	-

7

APG15 - 5-Ton Models

Motor Speed	T1				T2				T3				T4				T5			
	E.S.P	CFM	Watts	RPM	Amps	CFM	Watts	RPM	Amps	CFM	Watts	RPM	Amps	CFM	Watts	RPM	Amps	CFM	Watts	RPM
0.1	1773	488	892	3.64	1773	488	892	3.64	1379	246	720	1.95	1919	700	1010	4.81	2115	783	1034	5.54
0.2	1713	501	921	3.73	1713	501	921	3.73	1322	258	753	2.03	1862	714	1032	4.94	2078	787	1034	5.57
0.3	1693	509	944	3.78	1693	509	944	3.78	1268	266	785	2.1	1810	720	1055	5.01	2009	802	1070	5.67
0.4	1653	518	964	3.84	1653	518	964	3.84	1187	280	818	2.19	1755	734	1064	5.07	1953	813	1090	5.87
0.5	1597	529	988	3.91	1597	529	988	3.91	1133	287	849	2.23	1705	743	1085	5.09	1933	805	1102	5.77
0.6	1534	541	1010	3.99	1534	541	1010	3.99	1068	294	879	2.29	1647	748	1105	5.16	-	-	-	-
0.7	1485	552	1035	4.09	1485	552	1035	4.09	1026	307	911	2.38	-	-	-	-	-	-	-	-
0.8	-	-	-	-	-	-	-	-	-	-	-	-	-	-	-	-	-	-	-	-

EVAPORATOR BLOWER SPECIFICATIONS (CONT.)

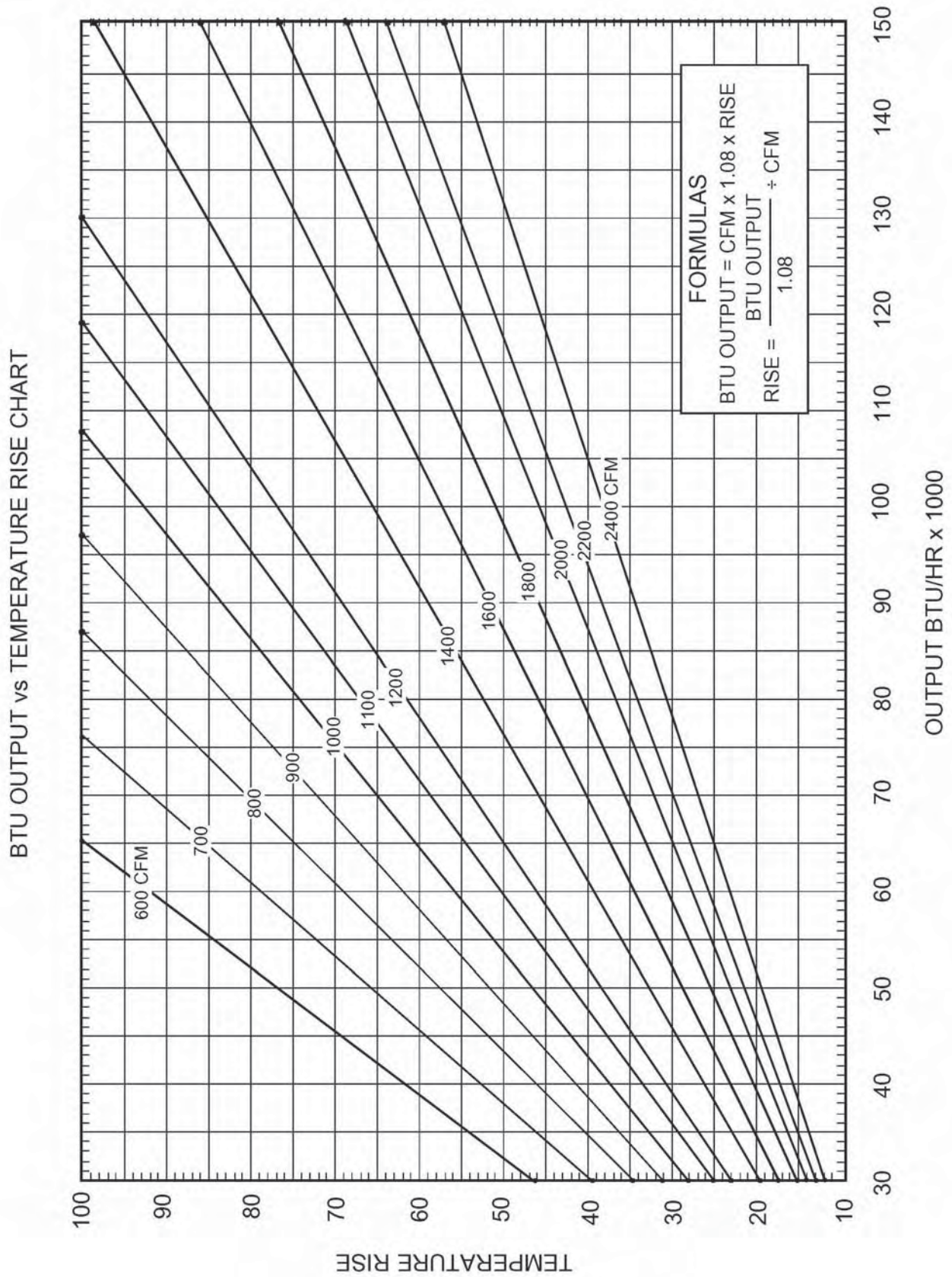

EXPANDED COOLING DATA — APG1524***41**

IDB	Airflow	Outdoor Ambient Temperature																								
		65°F				75°F				85°F				95°F				105°F				115°F				
		59	63	67	71	59	63	67	71	59	63	67	71	59	63	67	71	59	63	67	71	59	63	67	71	
70	951	MBh	22.7	23.6	25.8	-	22.2	23.0	25.2	-	21.7	22.5	24.6	-	21.1	21.9	24.0	-	20.1	20.8	22.8	-	18.6	19.3	21.1	-
		S/T	0.78	0.65	0.45	-	0.81	0.68	0.47	-	0.83	0.70	0.48	-	0.86	0.72	0.50	-	0.89	0.74	0.52	-	0.90	0.75	0.52	-
		ΔT	17	15	11	-	17	15	11	-	17	15	11	-	18	15	12	-	17	15	11	-	16	14	11	-
		kW	1.51	1.54	1.59	-	1.62	1.66	1.71	-	1.72	1.76	1.82	-	1.82	1.86	1.92	-	1.89	1.93	2.00	-	1.96	2.00	2.07	-
		Amps	7.0	7.2	7.4	-	7.5	7.7	7.9	-	8.0	8.2	8.4	-	8.5	8.7	8.9	-	9.0	9.2	9.4	-	9.4	9.6	9.9	-
	845	Hi PR	227	244	257	-	254	274	289	-	289	311	328	-	329	354	374	-	370	399	421	-	409	440	465	-
		Lo PR	109	116	127	-	115	123	134	-	120	128	139	-	126	134	146	-	132	140	153	-	137	145	159	-
		MBh	22.1	22.9	25.1	-	21.6	22.3	24.5	-	21.0	21.8	23.9	-	20.5	21.3	23.3	-	19.5	20.2	22.2	-	18.1	18.7	20.5	-
		S/T	0.75	0.62	0.43	-	0.77	0.65	0.45	-	0.79	0.66	0.46	-	0.82	0.68	0.47	-	0.85	0.71	0.49	-	0.86	0.72	0.50	-
		ΔT	18	16	12	-	18	16	12	-	18	16	12	-	18	16	12	-	18	16	12	-	17	15	11	-
739	kW	1.49	1.53	1.57	-	1.61	1.64	1.70	-	1.71	1.75	1.80	-	1.80	1.84	1.90	-	1.88	1.92	1.98	-	1.94	1.99	2.05	-	
	Amps	7.0	7.1	7.3	-	7.4	7.6	7.8	-	8.0	8.1	8.4	-	8.4	8.6	8.9	-	8.9	9.1	9.3	-	9.4	9.6	9.8	-	
	Hi PR	224	241	255	-	252	271	286	-	286	308	325	-	326	351	370	-	367	395	417	-	405	436	460	-	
	Lo PR	108	115	126	-	114	122	133	-	119	126	138	-	125	133	145	-	131	139	152	-	135	144	157	-	
	MBh	20.4	21.1	23.1	-	19.9	20.6	22.6	-	19.4	20.1	22.1	-	19.0	19.6	21.5	-	18.0	18.7	20.4	-	16.7	17.3	18.9	-	

75	951	MBh	23.1	23.8	25.8	27.7	22.6	23.3	25.2	27.0	22.0	22.7	24.6	26.4	21.5	22.1	24.0	25.7	20.4	21.0	22.8	24.4	18.9	19.5	21.1	22.6
		S/T	0.89	0.80	0.60	0.39	0.92	0.83	0.62	0.40	0.95	0.85	0.64	0.41	0.98	0.87	0.66	0.43	1.00	0.91	0.69	0.44	1.00	0.91	0.69	0.45
		ΔT	20	18	15	10	20	19	15	10	20	19	15	11	20	19	15	11	20	18	15	10	18	17	14	10
		kW	1.52	1.55	1.60	1.65	1.64	1.67	1.72	1.78	1.74	1.78	1.84	1.90	1.83	1.87	1.93	2.00	1.91	1.95	2.02	2.08	1.98	2.02	2.09	2.16
		Amps	7.1	7.2	7.4	7.6	7.6	7.7	7.9	8.2	8.1	8.3	8.5	8.8	8.6	8.7	9.0	9.3	9.0	9.2	9.5	9.8	9.5	9.7	10.0	10.3
	845	Hi PR	229	246	260	271	257	276	292	304	292	314	332	346	333	358	378	394	374	403	425	443	413	445	470	490
		Lo PR	110	117	128	136	117	124	135	144	121	129	141	150	127	135	148	157	133	142	155	165	138	147	160	171
		MBh	22.4	23.1	25.0	26.8	21.9	22.6	24.4	26.2	21.4	22.0	23.9	25.6	20.9	21.5	23.3	25.0	19.8	20.4	22.1	23.7	18.4	18.9	20.5	22.0
		S/T	0.85	0.76	0.57	0.37	0.88	0.79	0.60	0.38	0.90	0.81	0.61	0.39	0.93	0.83	0.63	0.41	0.97	0.86	0.65	0.42	0.98	0.87	0.66	0.42
		ΔT	21	19	16	11	21	19	16	11	21	19	16	11	21	19	16	11	21	19	16	11	19	18	15	10
739	kW	1.51	1.54	1.59	1.64	1.62	1.66	1.71	1.77	1.72	1.76	1.82	1.88	1.82	1.86	1.92	1.98	1.89	1.93	2.00	2.07	1.96	2.00	2.07	2.14	
	Amps	7.0	7.2	7.4	7.6	7.5	7.7	7.9	8.1	8.0	8.2	8.4	8.7	8.5	8.7	8.9	9.2	9.0	9.2	9.4	9.7	9.4	9.6	9.9	10.2	
	Hi PR	227	244	257	269	254	274	289	301	289	311	329	343	329	354	374	390	370	399	421	439	409	441	465	485	
	Lo PR	109	116	127	135	115	123	134	143	120	128	139	148	126	134	146	156	132	140	153	163	137	145	159	169	
	MBh	20.7	21.3	23.1	24.8	20.2	20.8	22.6	24.2	19.8	20.3	22.0	23.6	19.3	19.8	21.5	23.1	18.3	18.9	20.4	21.9	17.0	17.5	18.9	20.3	

Shaded area reflects ACCA (TVA) conditions IDB: Entering Indoor Dry Bulb Temperature kW = Total system power Amps = outdoor unit amps (comp. +fan)
 High and low pressures are measured at the liquid and suction service valves.

EXPANDED COOLING DATA — APG1524***41** (CONT.)

IDB	Airflow	Outdoor Ambient Temperature												Entering Indoor Wet Bulb Temperature											
		65°F				75°F				85°F				95°F				105°F				115°F			
		59	63	67	71	59	63	67	71	59	63	67	71	59	63	67	71	59	63	67	71	59	63	67	71
80	MBh	23.5	24.0	25.7	27.5	23.0	23.5	25.1	26.8	22.4	22.9	24.5	26.2	21.9	22.4	23.9	25.5	20.8	21.2	22.7	24.3	19.3	19.7	21.0	22.5
	S/T	1.00	0.92	0.75	0.56	1.00	0.95	0.77	0.58	1.00	1.00	0.79	0.59	1.00	1.00	0.82	0.61	1.00	1.00	0.85	0.63	1.00	1.00	0.86	0.64
	ΔT	23	21	19	15	22	22	19	15	22	22	19	15	21	22	19	15	21	19	15	15	19	19	17	14
	kW	1.53	1.56	1.61	1.66	1.65	1.68	1.74	1.80	1.75	1.79	1.85	1.91	1.85	1.89	1.95	2.01	1.92	1.97	2.03	2.10	1.99	2.04	2.11	2.18
	Amps	7.1	7.3	7.5	7.7	7.6	7.8	8.0	8.2	8.2	8.3	8.6	8.8	8.6	8.8	9.1	9.4	9.1	9.3	9.6	9.9	9.6	9.8	10.1	10.4
	Hi-PR	231	249	263	274	259	279	295	307	295	317	335	350	336	362	382	398	378	407	430	448	418	449	475	495
	Lo-PR	111	119	129	138	118	125	137	146	122	130	142	151	129	137	149	159	135	143	156	167	139	148	162	172
	MBh	22.8	23.3	24.9	26.7	22.3	22.8	24.4	26.0	21.8	22.3	23.8	25.4	21.3	21.7	23.2	24.8	20.2	20.6	22.0	23.6	18.7	19.1	20.4	21.8
	S/T	0.93	0.87	0.71	0.53	0.97	0.91	0.74	0.55	0.99	0.93	0.76	0.56	1.00	0.96	0.78	0.58	1.00	0.99	0.81	0.61	1.00	1.00	0.82	0.61
	ΔT	23	22	19	15	23	22	20	16	23	22	20	16	23	23	20	16	22	22	19	16	20	21	18	14
kW	1.52	1.55	1.60	1.65	1.64	1.67	1.73	1.78	1.74	1.78	1.84	1.90	1.83	1.87	1.93	2.00	1.91	1.95	2.02	2.08	1.98	2.02	2.09	2.16	
Amps	7.1	7.2	7.4	7.7	7.6	7.7	7.9	8.2	8.1	8.3	8.5	8.8	8.6	8.8	9.0	9.3	9.0	9.2	9.5	9.8	9.5	9.7	10.0	10.3	
Hi-PR	229	246	260	271	257	276	292	304	292	314	332	346	333	358	378	394	374	403	425	444	413	445	470	490	
Lo-PR	110	117	128	136	117	124	135	144	121	129	141	150	127	135	148	157	133	142	155	165	138	147	160	171	
MBh	21.1	21.5	23.0	24.6	20.6	21.0	22.5	24.0	20.1	20.5	21.9	23.5	19.6	20.0	21.4	22.9	18.6	19.0	20.3	21.7	17.3	17.6	18.8	20.1	
S/T	0.90	0.84	0.69	0.51	0.93	0.87	0.71	0.53	0.95	0.90	0.73	0.54	0.99	0.92	0.75	0.56	1.02	0.96	0.78	0.58	1.03	0.97	0.79	0.59	
ΔT	24	23	20	16	24	23	20	16	24	23	20	16	24	24	23	20	24	23	20	16	22	21	18	15	
kW	1.48	1.51	1.56	1.61	1.60	1.63	1.68	1.74	1.70	1.73	1.79	1.85	1.78	1.82	1.88	1.95	1.86	1.90	1.96	2.03	1.93	1.97	2.03	2.10	
Amps	6.9	7.1	7.3	7.5	7.4	7.5	7.7	8.0	7.9	8.1	8.3	8.6	8.4	8.5	8.8	9.1	8.8	9.0	9.3	9.6	9.3	9.5	9.7	10.1	
Hi-PR	222	239	252	263	249	268	283	295	283	305	322	336	323	347	367	382	363	391	412	430	401	432	456	475	
Lo-PR	107	114	124	132	113	120	131	140	118	125	136	145	123	131	143	153	129	138	150	160	134	142	155	165	

85	MBh	23.9	24.4	25.6	27.3	23.4	23.8	25.0	26.6	22.8	23.3	24.4	26.0	22.3	22.7	23.8	25.4	21.2	21.6	22.6	24.1	19.6	20.0	20.9	22.3
	S/T	1.00	0.99	0.89	0.72	1.00	1.00	0.92	0.75	1.00	1.00	0.95	0.77	1.00	1.00	0.98	0.79	1.00	1.00	1.00	0.82	1.00	1.00	1.00	0.83
	ΔT	23	23	22	19	23	23	22	19	22	23	22	19	22	22	22	19	20	21	22	19	19	19	20	18
	kW	1.54	1.58	1.63	1.68	1.66	1.70	1.75	1.81	1.77	1.81	1.87	1.93	1.86	1.90	1.97	2.03	1.94	1.98	2.05	2.12	2.01	2.05	2.12	2.20
	Amps	7.2	7.3	7.5	7.8	7.7	7.8	8.0	8.3	8.2	8.4	8.6	8.9	8.7	8.9	9.1	9.4	9.2	9.4	9.7	10.0	9.7	9.9	10.2	10.5
	Hi-PR	233	251	265	277	262	282	298	310	298	321	339	353	339	365	386	402	382	411	434	452	422	454	479	500
	Lo-PR	113	120	131	139	119	126	138	147	124	131	144	153	130	138	151	161	136	145	158	168	141	150	163	174
	MBh	23.2	23.7	24.8	26.5	22.7	23.1	24.2	25.9	22.2	22.6	23.7	25.2	21.6	22.0	23.1	24.6	20.5	20.9	21.9	23.4	19.0	19.4	20.3	21.7
	S/T	0.98	0.94	0.85	0.69	1.00	0.98	0.88	0.72	1.00	1.00	0.90	0.73	1.00	1.00	0.93	0.76	1.00	1.00	0.97	0.79	1.00	1.00	0.98	0.79
	ΔT	25	24	23	20	25	25	23	20	24	25	23	20	24	24	23	20	22	23	23	20	21	21	22	19
kW	1.53	1.56	1.61	1.66	1.65	1.68	1.74	1.80	1.75	1.79	1.85	1.91	1.85	1.89	1.95	2.01	1.92	1.97	2.03	2.10	1.99	2.04	2.11	2.18	
Amps	7.1	7.3	7.5	7.7	7.6	7.8	8.0	8.2	8.2	8.3	8.6	8.8	8.6	8.8	9.1	9.4	9.1	9.3	9.6	9.9	9.6	9.8	10.1	10.4	
Hi-PR	231	249	263	274	259	279	295	307	295	317	335	350	336	362	382	398	378	407	430	448	418	449	475	495	
Lo-PR	111	119	129	138	118	125	137	146	122	130	142	151	129	137	149	159	135	143	156	167	139	148	162	172	
MBh	21.5	21.9	22.9	24.4	21.0	21.4	22.4	23.9	20.5	20.9	21.8	23.3	20.0	20.3	21.3	22.7	19.0	19.3	20.2	21.6	17.6	17.9	18.7	20.0	
S/T	0.94	0.91	0.82	0.67	0.98	0.94	0.85	0.69	1.00	0.97	0.87	0.71	1.00	1.00	0.90	0.73	1.00	1.00	0.93	0.76	1.00	1.00	0.94	0.76	
ΔT	25	25	23	20	25	25	24	20	25	25	24	20	25	25	24	21	24	24	23	20	22	22	22	19	
kW	1.49	1.53	1.57	1.62	1.61	1.64	1.70	1.75	1.71	1.75	1.80	1.86	1.80	1.84	1.90	1.96	1.88	1.92	1.98	2.05	1.94	1.99	2.05	2.12	
Amps	7.0	7.1	7.3	7.5	7.4	7.6	7.8	8.0	8.0	8.1	8.4	8.6	8.4	8.6	8.9	9.1	8.9	9.1	9.3	9.7	9.3	9.5	9.8	10.2	
Hi-PR	224	241	255	266	252	271	286	298	286	308	325	339	326	351	370	386	367	395	417	435	405	436	460	480	
Lo-PR	108	115	126	134	114	121	133	141	119	126	138	147	125	133	145	154	131	139	152	162	135	144	157	167	

Shaded area reflects ARI conditions
 High and low pressures are measured at the liquid and suction service valves.
 IDB: Entering Indoor Dry Bulb Temperature
 kW = Total system power
 Amps = outdoor unit amps (comp.-fan)

EXPANDED COOLING DATA — APG1536***41** — SINGLE STAGE

IDB	Airflow	Outdoor Ambient Temperature																							
		65°F				75°F				85°F				95°F				105°F				115°F			
		59	63	67	71	59	63	67	71	59	63	67	71	59	63	67	71	59	63	67	71	59	63	67	71
900	MBh	23.9	24.8	27.2	-	23.4	24.2	26.5	-	22.8	23.6	25.9	-	22.2	23.1	25.3	-	21.1	21.9	24.0	-	19.6	20.3	22.2	-
	S/T	0.76	0.64	0.44	-	0.79	0.66	0.46	-	0.81	0.68	0.47	-	0.84	0.70	0.48	-	0.87	0.73	0.50	-	0.88	0.73	0.51	-
	ΔT	19	16	12	-	19	16	12	-	19	16	12	-	19	16	13	-	19	16	12	-	18	15	12	-
	kW	1.59	1.63	1.68	-	1.71	1.75	1.80	-	1.82	1.86	1.92	-	1.91	1.95	2.02	-	1.99	2.03	2.10	-	2.06	2.10	2.17	-
	Amps	7.2	7.3	7.5	-	7.7	7.8	8.1	-	8.2	8.4	8.7	-	8.7	8.9	9.2	-	9.2	9.4	9.7	-	9.7	9.9	10.2	-
	Hi PR	225	242	256	-	253	272	287	-	287	309	326	-	327	352	372	-	368	396	418	-	407	438	462	-
	Lo PR	111	118	128	-	117	124	136	-	121	129	141	-	128	136	148	-	134	142	155	-	138	147	161	-
	MBh	23.2	24.1	26.4	-	22.7	23.5	25.7	-	22.1	22.9	25.1	-	21.6	22.4	24.5	-	20.5	21.3	23.3	-	19.0	19.7	21.6	-
	S/T	0.73	0.61	0.42	-	0.75	0.63	0.44	-	0.77	0.65	0.45	-	0.80	0.67	0.46	-	0.83	0.69	0.48	-	0.84	0.70	0.48	-
	ΔT	19	17	13	-	20	17	13	-	20	17	13	-	20	17	13	-	20	17	13	-	18	16	12	-
70	kW	1.58	1.62	1.66	-	1.70	1.74	1.79	-	1.80	1.84	1.90	-	1.90	1.94	2.00	-	1.97	2.02	2.08	-	2.04	2.09	2.15	-
	Amps	7.1	7.3	7.5	-	7.6	7.8	8.0	-	8.2	8.3	8.6	-	8.7	8.8	9.1	-	9.1	9.3	9.6	-	9.6	9.8	10.1	-
	Hi PR	223	240	253	-	250	269	284	-	284	306	323	-	324	349	368	-	364	392	414	-	403	433	458	-
	Lo PR	109	116	127	-	116	123	134	-	120	128	140	-	126	134	147	-	132	141	154	-	137	146	159	-
	MBh	21.4	22.2	24.3	-	20.9	21.7	23.8	-	20.4	21.2	23.2	-	19.9	20.7	22.6	-	18.9	19.6	21.5	-	17.5	18.2	19.9	-
	S/T	0.70	0.59	0.41	-	0.73	0.61	0.42	-	0.75	0.62	0.43	-	0.77	0.64	0.45	-	0.80	0.67	0.46	-	0.81	0.67	0.47	-
	ΔT	20	17	13	-	20	17	13	-	20	17	13	-	20	17	13	-	20	17	13	-	19	16	12	-
	kW	1.55	1.58	1.63	-	1.66	1.70	1.75	-	1.76	1.80	1.86	-	1.85	1.89	1.95	-	1.93	1.97	2.03	-	1.99	2.04	2.10	-
	Amps	7.0	7.1	7.3	-	7.4	7.6	7.8	-	8.0	8.1	8.4	-	8.4	8.6	8.9	-	8.9	9.1	9.4	-	9.4	9.6	9.9	-
	Hi PR	216	233	246	-	243	261	276	-	276	297	314	-	314	338	357	-	353	380	402	-	391	420	444	-
Lo PR	106	113	123	-	112	119	130	-	117	124	135	-	122	130	142	-	128	137	149	-	133	141	154	-	

900	MBh	24.3	25.0	27.1	29.1	23.7	24.5	26.5	28.4	23.2	23.9	25.8	27.7	22.6	23.3	25.2	27.1	21.5	22.1	23.9	25.7	19.9	20.5	22.2	23.8
	S/T	0.87	0.78	0.59	0.38	0.90	0.80	0.61	0.39	0.92	0.82	0.62	0.40	0.95	0.85	0.64	0.41	0.99	0.88	0.67	0.43	1.00	0.89	0.67	0.43
	ΔT	22	20	16	11	22	20	16	11	22	20	16	11	22	20	17	11	22	20	16	11	20	19	15	11
	kW	1.61	1.64	1.69	1.74	1.73	1.76	1.82	1.88	1.83	1.87	1.93	2.00	1.93	1.97	2.03	2.10	2.01	2.05	2.12	2.19	2.08	2.12	2.19	2.26
	Amps	7.2	7.4	7.6	7.8	7.7	7.9	8.1	8.4	8.3	8.5	8.7	9.0	8.8	9.0	9.2	9.5	9.3	9.5	9.8	10.1	9.8	10.0	10.3	10.6
	Hi PR	227	245	258	270	255	275	290	302	290	312	330	344	331	356	376	392	372	400	423	441	411	442	467	487
	Lo PR	112	119	130	138	118	126	137	146	123	130	142	152	129	137	150	159	135	144	157	167	140	149	162	173
	MBh	23.6	24.3	26.3	28.2	23.1	23.7	25.7	27.6	22.5	23.2	25.1	26.9	22.0	22.6	24.5	26.3	20.9	21.5	23.2	25.0	19.3	19.9	21.5	23.1
	S/T	0.83	0.74	0.56	0.36	0.86	0.77	0.58	0.37	0.88	0.79	0.60	0.38	0.91	0.81	0.61	0.40	0.94	0.84	0.64	0.41	0.95	0.85	0.64	0.41
	ΔT	22	21	17	12	23	21	17	12	23	21	17	12	23	21	17	12	23	21	17	12	21	19	16	11
75	kW	1.60	1.63	1.68	1.73	1.71	1.75	1.80	1.86	1.82	1.86	1.92	1.98	1.91	1.95	2.02	2.08	1.99	2.03	2.10	2.17	2.06	2.10	2.17	2.25
	Amps	7.2	7.3	7.5	7.8	7.7	7.8	8.1	8.3	8.2	8.4	8.7	8.9	8.7	8.9	9.2	9.5	9.2	9.4	9.7	10.0	9.7	9.9	10.2	10.5
	Hi PR	225	242	256	267	253	272	287	299	287	309	326	341	327	352	372	388	368	396	418	436	407	438	462	482
	Lo PR	111	118	128	137	117	124	136	145	121	129	141	150	128	136	148	158	134	142	155	165	138	147	161	171
	MBh	21.8	22.4	24.3	26.1	21.3	21.9	23.7	25.5	20.8	21.4	23.2	24.8	20.3	20.9	22.6	24.2	19.3	19.8	21.5	23.0	17.8	18.4	19.9	21.3
	S/T	0.80	0.71	0.54	0.35	0.83	0.74	0.56	0.36	0.85	0.76	0.57	0.37	0.88	0.78	0.59	0.38	0.91	0.81	0.62	0.40	0.92	0.82	0.62	0.40
	ΔT	23	21	17	12	23	21	17	12	23	21	17	12	23	21	18	12	23	21	17	12	21	20	16	11
	kW	1.56	1.59	1.64	1.69	1.67	1.71	1.76	1.82	1.78	1.81	1.87	1.93	1.87	1.91	1.97	2.03	1.94	1.98	2.05	2.12	2.01	2.05	2.12	2.19
	Amps	7.0	7.2	7.4	7.6	7.5	7.7	7.9	8.1	8.0	8.2	8.4	8.7	8.5	8.7	8.9	9.2	9.0	9.2	9.4	9.8	9.5	9.7	9.9	10.3
	Hi PR	218	235	248	259	245	264	278	290	279	300	317	330	317	342	361	376	357	384	406	423	395	425	448	468
Lo PR	107	114	125	133	113	121	132	140	118	125	137	146	124	132	144	153	130	138	151	160	134	143	156	166	

Shaded area reflects ACCA (TVA) conditions IDB: Entering Indoor Dry Bulb Temperature kW = Total system power Amps = outdoor unit amps (comp.+fan)
 High and low pressures are measured at the liquid and suction service valves.

EXPANDED COOLING DATA — APG1536***41** — SINGLE STAGE (CONT.)

IDB	Airflow	Outdoor Ambient Temperature																									
		65°F				75°F				85°F				95°F				105°F				115°F					
		59	63	67	71	59	63	67	71	59	63	67	71	59	63	67	71	59	63	67	71	59	63	67	71		
80	900	MBh	24.7	25.3	27.0	28.9	24.2	24.7	26.4	28.2	23.6	24.1	25.8	27.5	23.0	23.5	25.1	26.9	21.9	22.3	23.9	25.5	20.3	20.7	22.1	23.6	
		S/T	0.95	0.89	0.73	0.54	1.00	0.93	0.75	0.56	1.00	0.95	0.77	0.58	1.00	1.00	0.80	0.60	1.00	1.00	0.83	0.62	1.00	1.00	0.83	0.62	
		ΔT	24	23	20	16	25	23	20	16	24	23	20	16	24	24	20	16	22	23	20	16	21	21	19	15	
	800	kW	1.62	1.65	1.70	1.76	1.74	1.78	1.83	1.89	1.85	1.89	1.95	2.01	1.94	1.99	2.05	2.12	2.02	2.07	2.14	2.21	2.09	2.14	2.21	2.28	
		Amps	7.3	7.4	7.7	7.9	7.8	8.0	8.2	8.4	8.4	8.5	8.8	9.1	8.9	9.1	9.3	9.6	9.4	9.6	9.8	10.2	9.9	10.1	10.4	10.7	
		Hi-PR	230	247	261	272	258	277	293	305	293	315	333	347	334	359	379	396	376	404	427	445	415	447	472	492	
	700	Lo-PR	113	120	131	140	119	127	138	147	124	132	144	153	130	138	151	161	136	145	158	169	141	150	164	174	
		MBh	24.0	24.6	26.2	28.0	23.5	24.0	25.6	27.4	22.9	23.4	25.0	26.7	22.4	22.8	24.4	26.1	21.2	21.7	23.2	24.8	19.7	20.1	21.5	23.0	
		S/T	0.91	0.85	0.69	0.52	0.94	0.88	0.72	0.54	0.96	0.90	0.74	0.55	1.00	0.93	0.76	0.57	1.00	0.97	0.79	0.59	1.00	0.98	0.80	0.59	
	85	900	ΔT	25	24	21	17	25	24	21	17	25	24	21	17	26	25	21	17	24	24	21	17	23	23	20	16
			kW	1.61	1.64	1.69	1.74	1.73	1.76	1.82	1.88	1.83	1.87	1.93	2.00	1.93	1.97	2.03	2.10	2.01	2.05	2.12	2.19	2.08	2.12	2.19	2.26
			Amps	7.2	7.4	7.6	7.8	7.7	7.9	8.1	8.4	8.3	8.5	8.7	9.0	8.8	9.0	9.2	9.5	9.3	9.5	9.8	10.1	9.8	10.0	10.3	10.6
800		Hi-PR	227	245	258	270	255	275	290	302	290	312	330	344	331	356	376	392	372	400	423	441	411	442	467	487	
		Lo-PR	112	119	130	138	118	126	137	146	123	130	142	152	129	137	150	159	135	144	157	167	140	149	162	173	
		MBh	22.2	22.7	24.2	25.9	21.7	22.1	23.6	25.3	21.1	21.6	23.1	24.7	20.6	21.1	22.5	24.1	19.6	20.0	21.4	22.9	18.2	18.6	19.8	21.2	
700		S/T	0.88	0.82	0.67	0.50	0.91	0.85	0.69	0.52	0.93	0.87	0.71	0.53	0.96	0.90	0.73	0.55	1.00	0.93	0.76	0.57	1.00	0.94	0.77	0.57	
		ΔT	25	24	21	17	26	25	22	17	26	25	22	17	26	25	22	17	26	25	21	17	24	23	20	16	
		kW	1.57	1.60	1.65	1.70	1.69	1.72	1.78	1.83	1.79	1.83	1.89	1.95	1.88	1.92	1.98	2.05	1.96	2.00	2.07	2.13	2.03	2.07	2.14	2.21	
600		Amps	7.1	7.2	7.4	7.7	7.6	7.7	7.9	8.2	8.1	8.3	8.5	8.8	8.6	8.8	9.0	9.3	9.1	9.3	9.5	9.8	9.5	9.7	10.0	10.4	
		Hi-PR	221	237	251	261	248	266	281	293	282	303	320	334	321	345	364	380	361	388	410	428	399	429	453	472	
		Lo-PR	108	115	126	134	114	122	133	142	119	127	138	147	125	133	145	155	131	139	152	162	135	144	157	168	
85	900	MBh	25.2	25.7	26.9	28.7	24.6	25.1	26.3	28.0	24.0	24.5	25.6	27.3	23.4	23.9	25.0	26.7	22.3	22.7	23.8	25.3	20.6	21.0	22.0	23.5	
		S/T	1.00	0.96	0.87	0.70	1.00	1.00	0.90	0.73	1.00	1.00	0.92	0.75	1.00	1.00	0.95	0.77	1.00	1.00	0.99	0.80	1.00	1.00	1.00	0.81	
		ΔT	26	25	24	21	25	26	24	21	25	25	24	21	24	24	24	21	23	23	24	21	21	21	22	19	
	800	kW	1.63	1.67	1.72	1.77	1.76	1.79	1.85	1.91	1.86	1.90	1.96	2.03	1.96	2.00	2.07	2.13	2.04	2.09	2.15	2.22	2.11	2.16	2.23	2.30	
		Amps	7.4	7.5	7.7	8.0	7.9	8.0	8.2	8.5	8.4	8.6	8.9	9.2	8.9	9.1	9.4	9.7	9.4	9.6	9.9	10.3	9.9	10.1	10.5	10.8	
		Hi-PR	232	250	264	275	260	280	296	309	296	319	336	351	337	363	383	400	379	408	431	450	419	451	476	497	
	700	Lo-PR	114	121	132	141	120	128	140	149	125	133	145	155	131	140	153	163	138	147	160	170	142	152	165	176	
		MBh	24.4	24.9	26.1	27.8	23.9	24.3	25.5	27.2	23.3	23.8	24.9	26.5	22.7	23.2	24.3	25.9	21.6	22.0	23.1	24.6	20.0	20.4	21.4	22.8	
		S/T	0.95	0.92	0.83	0.67	0.99	0.95	0.86	0.70	1.00	0.98	0.88	0.71	1.00	1.00	0.91	0.74	1.00	1.00	0.94	0.77	1.00	1.00	0.95	0.77	
	600	ΔT	27	26	25	22	27	27	25	22	27	27	25	22	26	27	25	22	25	25	25	22	23	23	23	20	
		kW	1.62	1.65	1.70	1.76	1.74	1.78	1.83	1.89	1.85	1.89	1.95	2.01	1.94	1.99	2.05	2.12	2.02	2.07	2.14	2.21	2.09	2.14	2.21	2.28	
		Amps	7.3	7.4	7.7	7.9	7.8	8.0	8.2	8.4	8.4	8.5	8.8	9.1	8.9	9.1	9.3	9.6	9.4	9.6	9.8	10.2	9.9	10.1	10.4	10.7	
500	Hi-PR	230	247	261	272	258	277	293	305	293	315	333	347	334	359	379	396	376	404	427	445	415	447	472	492		
	Lo-PR	113	120	131	140	119	127	138	147	124	132	144	153	130	138	151	161	136	145	158	169	141	150	164	174		
	MBh	22.6	23.0	24.1	25.7	22.0	22.5	23.5	25.1	21.5	21.9	23.0	24.5	21.0	21.4	22.4	23.9	19.9	20.3	21.3	22.7	18.5	18.8	19.7	21.0		
400	S/T	0.92	0.89	0.80	0.65	0.95	0.92	0.83	0.67	0.98	0.94	0.85	0.69	1.00	0.97	0.88	0.71	1.00	1.00	0.91	0.74	1.00	1.00	0.92	0.74		
	ΔT	27	27	25	22	28	27	26	22	28	27	26	22	28	27	26	22	26	27	25	22	24	25	24	21		
	kW	1.58	1.61	1.66	1.72	1.70	1.74	1.79	1.85	1.80	1.84	1.90	1.96	1.90	1.94	2.00	2.06	1.97	2.02	2.08	2.15	2.04	2.09	2.15	2.23		
300	Amps	7.1	7.3	7.5	7.7	7.6	7.8	8.0	8.2	8.2	8.3	8.6	8.9	8.7	8.8	9.1	9.4	9.1	9.3	9.6	9.9	9.6	9.8	10.1	10.5		
	Hi-PR	223	240	253	264	250	269	284	296	284	306	323	337	324	348	368	384	364	392	414	432	403	433	457	477		
	Lo-PR	109	116	127	135	116	123	134	143	120	128	140	149	126	134	147	156	132	141	154	164	137	146	159	169		

Shaded area reflects ARI conditions IDB: Entering Indoor Dry Bulb Temperature kW = Total system power Amps = outdoor unit amps (comp.+fan)
 High and low pressures are measured at the liquid and suction service valves.

EXPANDED COOLING DATA — APG1536***41** — Two Stage

IDB	Airflow	Outdoor Ambient Temperature																							
		65°F				75°F				85°F				95°F				105°F				115°F			
		59	63	67	71	59	63	67	71	59	63	67	71	59	63	67	71	59	63	67	71	59	63	67	71
	MBh	34.7	36.0	39.4	-	33.9	35.1	38.5	-	33.1	34.3	37.6	-	32.3	33.4	36.6	-	30.7	31.8	34.8	-	28.4	29.4	32.2	-
	S/T	0.77	0.65	0.45	-	0.80	0.67	0.46	-	0.82	0.69	0.48	-	0.85	0.71	0.49	-	0.88	0.74	0.51	-	0.89	0.74	0.51	-
	ΔT	18	15	12	-	18	16	12	-	18	16	12	-	18	16	12	-	18	16	12	-	17	15	11	-
1378	kW	2.52	2.58	2.65	-	2.71	2.77	2.86	-	2.88	2.94	3.03	-	3.03	3.09	3.19	-	3.15	3.22	3.33	-	3.26	3.33	3.44	-
	Amps	12.7	12.9	13.2	-	13.4	13.7	14.0	-	14.3	14.6	15.0	-	15.1	15.4	15.8	-	15.8	16.2	16.6	-	16.6	16.9	17.4	-
	Hi PR	252	271	286	-	282	304	321	-	321	346	365	-	366	394	416	-	412	443	468	-	455	489	517	-
	Lo PR	110	117	128	-	116	124	135	-	121	129	140	-	127	135	147	-	133	142	154	-	138	146	160	-
	MBh	33.7	34.9	38.2	-	32.9	34.1	37.4	-	32.1	33.3	36.5	-	31.3	32.5	35.6	-	29.8	30.8	33.8	-	27.6	28.6	31.3	-
	S/T	0.74	0.62	0.43	-	0.76	0.64	0.44	-	0.78	0.65	0.45	-	0.81	0.68	0.47	-	0.84	0.70	0.49	-	0.85	0.71	0.49	-
	ΔT	19	16	12	-	19	16	12	-	19	16	12	-	19	16	12	-	19	16	12	-	18	15	12	-
70	kW	2.50	2.56	2.63	-	2.69	2.75	2.83	-	2.86	2.92	3.01	-	3.00	3.07	3.17	-	3.13	3.19	3.30	-	3.23	3.30	3.41	-
	Amps	12.6	12.8	13.1	-	13.3	13.6	13.9	-	14.2	14.5	14.9	-	15.0	15.3	15.7	-	15.7	16.0	16.5	-	16.5	16.8	17.3	-
	Hi PR	249	268	283	-	280	301	318	-	318	342	361	-	362	390	412	-	408	439	463	-	450	485	512	-
	Lo PR	109	116	127	-	115	122	134	-	120	127	139	-	126	134	146	-	132	140	153	-	136	145	158	-
	MBh	31.1	32.2	35.3	-	30.4	31.5	34.5	-	29.6	30.7	33.7	-	28.9	30.0	32.8	-	27.5	28.5	31.2	-	25.4	26.4	28.9	-
	S/T	0.71	0.59	0.41	-	0.74	0.62	0.43	-	0.76	0.63	0.44	-	0.78	0.65	0.45	-	0.81	0.68	0.47	-	0.82	0.68	0.47	-
	ΔT	19	16	12	-	19	17	13	-	19	17	13	-	19	17	13	-	19	17	13	-	18	15	12	-
1072	kW	2.45	2.50	2.57	-	2.63	2.68	2.77	-	2.79	2.85	2.94	-	2.93	2.99	3.09	-	3.05	3.12	3.22	-	3.15	3.22	3.33	-
	Amps	12.3	12.5	12.8	-	13.1	13.3	13.6	-	13.9	14.2	14.5	-	14.6	14.9	15.3	-	15.4	15.7	16.1	-	16.1	16.4	16.9	-
	Hi PR	242	260	275	-	271	292	308	-	309	332	351	-	351	378	399	-	395	425	449	-	437	470	496	-
	Lo PR	106	112	123	-	112	119	130	-	116	123	135	-	122	130	142	-	128	136	148	-	132	141	153	-

	MBh	35.3	36.3	39.3	42.2	34.5	35.5	38.4	41.2	33.6	34.6	37.5	40.2	32.8	33.8	36.6	39.3	31.2	32.1	34.7	37.3	28.9	29.7	32.2	34.5
	S/T	0.88	0.79	0.60	0.38	0.91	0.81	0.62	0.40	0.93	0.84	0.63	0.41	0.96	0.86	0.65	0.42	1.00	0.90	0.68	0.44	1.00	0.90	0.68	0.44
	ΔT	21	19	16	11	21	19	16	11	21	19	16	11	21	19	16	11	21	19	16	11	19	18	15	10
1378	kW	2.54	2.60	2.68	2.76	2.73	2.79	2.88	2.97	2.90	2.97	3.06	3.16	3.05	3.12	3.22	3.32	3.18	3.25	3.35	3.47	3.29	3.36	3.47	3.59
	Amps	12.7	13.0	13.3	13.7	13.5	13.8	14.1	14.5	14.4	14.7	15.1	15.5	15.2	15.5	15.9	16.4	16.0	16.3	16.7	17.2	16.7	17.1	17.5	18.1
	Hi PR	254	274	289	301	285	307	324	338	325	349	369	385	370	398	420	438	416	447	473	493	459	494	522	545
	Lo PR	111	118	129	137	117	125	136	145	122	130	142	151	128	136	149	159	134	143	156	166	139	148	161	172
	MBh	34.2	35.3	38.2	41.0	33.5	34.4	37.3	40.0	32.7	33.6	36.4	39.1	31.9	32.8	35.5	38.1	30.3	31.2	33.7	36.2	28.0	28.9	31.2	33.5
	S/T	0.84	0.75	0.57	0.37	0.87	0.78	0.59	0.38	0.89	0.80	0.60	0.39	0.92	0.82	0.62	0.40	0.95	0.85	0.65	0.42	0.96	0.86	0.65	0.42
	ΔT	22	20	16	11	22	20	16	11	22	20	16	11	22	20	17	11	22	20	16	11	20	19	15	11
1225	kW	2.52	2.58	2.65	2.74	2.71	2.77	2.86	2.95	2.88	2.94	3.04	3.13	3.03	3.09	3.19	3.30	3.15	3.22	3.33	3.44	3.26	3.33	3.44	3.56
	Amps	12.7	12.9	13.2	13.6	13.4	13.7	14.0	14.4	14.3	14.6	15.0	15.4	15.1	15.4	15.8	16.3	15.8	16.2	16.6	17.1	16.6	16.9	17.4	17.9
	Hi PR	252	271	286	298	283	304	321	335	321	346	365	381	366	394	416	434	412	443	468	488	455	490	517	539
	Lo PR	110	117	128	136	116	124	135	144	121	129	140	149	127	135	147	157	133	142	155	165	138	146	160	170
	MBh	31.6	32.5	35.2	37.8	30.9	31.8	34.4	36.9	30.1	31.0	33.6	36.1	29.4	30.3	32.8	35.2	27.9	28.8	31.1	33.4	25.9	26.6	28.8	31.0
	S/T	0.81	0.72	0.55	0.35	0.84	0.75	0.57	0.36	0.86	0.77	0.58	0.37	0.89	0.79	0.60	0.39	0.92	0.82	0.62	0.40	0.93	0.83	0.63	0.40
	ΔT	22	20	17	11	22	20	17	12	22	20	17	12	22	21	17	12	22	20	17	11	21	19	16	11
1072	kW	2.46	2.52	2.59	2.67	2.65	2.70	2.79	2.88	2.81	2.87	2.96	3.06	2.95	3.02	3.11	3.22	3.08	3.14	3.24	3.35	3.18	3.25	3.36	3.47
	Amps	12.4	12.6	12.9	13.3	13.2	13.4	13.7	14.1	14.0	14.3	14.6	15.1	14.8	15.0	15.4	15.9	15.5	15.8	16.2	16.7	16.2	16.6	17.0	17.5
	Hi PR	244	263	278	289	274	295	311	325	312	335	354	369	355	382	403	421	399	430	454	473	441	475	501	523
	Lo PR	107	114	124	132	113	120	131	140	117	125	136	145	123	131	143	152	129	137	150	160	133	142	155	165

Shaded area reflects ACCA (TVA) conditions IDB: Entering Indoor Dry Bulb Temperature kW = Total system power Amps = outdoor unit amps (comp. +fan)
 High and low pressures are measured at the liquid and suction service valves.

EXPANDED COOLING DATA — APG1536***41** — TWO STAGE (CONT.)

	Outdoor Ambient Temperature																																																																																																																																																																																																																																																																																																																																																																																																																																																																																																																																														
	65°F					75°F					85°F					95°F					105°F					115°F																																																																																																																																																																																																																																																																																																																																																																																																																																																																																																																					
	59	63	67	71	75	59	63	67	71	75	59	63	67	71	75	59	63	67	71	75	59	63	67	71	75	59	63	67	71	75																																																																																																																																																																																																																																																																																																																																																																																																																																																																																																																	
IDB	Airflow																																																																																																																																																																																																																																																																																																																																																																																																																																																																																																																																														
	MBh	35.9	36.7	39.2	41.9	35.1	35.8	38.3	40.9	34.2	35.0	37.4	40.0	33.4	34.1	36.5	39.0	31.7	32.4	34.6	37.0	29.4	30.0	32.1	34.3	S/T	0.96	0.90	0.74	0.55	1.00	0.94	0.76	0.57	1.00	0.96	0.78	0.58	1.00	1.00	0.81	0.60	1.00	1.00	0.84	0.63	1.00	1.00	0.84	0.63	ΔT	23	22	19	15	23	22	19	16	23	22	20	16	22	23	20	16	21	22	19	15	20	20	18	14	kW	2.56	2.62	2.70	2.78	2.76	2.81	2.90	3.00	2.93	2.99	3.08	3.19	3.08	3.14	3.25	3.35	3.20	3.28	3.38	3.49	3.32	3.39	3.50	3.62	Amps	12.8	13.1	13.4	13.8	13.6	13.9	14.2	14.6	15.3	14.8	15.2	15.6	15.3	15.6	16.0	16.4	16.1	16.4	16.8	17.4	16.9	17.2	17.7	18.2	Hi-PR	257	276	292	304	288	310	328	342	328	353	373	389	373	402	424	443	420	452	477	498	464	499	527	550	Lo-PR	112	119	130	139	119	126	138	147	123	131	143	152	130	138	150	160	136	144	158	168	140	149	163	174		MBh	34.9	35.6	38.1	40.7	34.0	34.8	37.2	39.7	33.2	34.0	36.3	38.8	32.4	33.1	35.4	37.8	30.8	31.5	33.6	36.0	28.5	29.2	31.2	33.3	S/T	0.92	0.86	0.70	0.52	0.95	0.89	0.73	0.54	0.98	0.92	0.75	0.56	1.00	0.95	0.77	0.58	1.00	0.98	0.80	0.60	1.00	0.99	0.81	0.60	ΔT	24	23	20	16	24	23	20	16	24	23	20	16	24	24	20	16	23	23	20	16	21	22	19	15	kW	2.54	2.60	2.68	2.76	2.73	2.79	2.88	2.97	2.90	2.97	3.06	3.16	3.05	3.12	3.22	3.33	3.18	3.25	3.35	3.47	3.29	3.36	3.47	3.59	Amps	12.7	13.0	13.3	13.7	13.5	13.8	14.1	14.5	14.4	14.7	15.1	15.5	15.2	15.5	15.9	16.4	16.0	16.3	16.7	17.2	16.7	17.1	17.5	18.1	Hi-PR	254	274	289	301	285	307	324	338	325	349	369	385	370	398	420	438	416	448	473	493	460	494	522	545	Lo-PR	111	118	129	138	117	125	136	145	122	130	142	151	128	136	149	159	134	143	156	166	139	148	161	172		MBh	32.2	32.9	35.1	37.5	31.4	32.1	34.3	36.7	30.7	31.3	33.5	35.8	29.9	30.6	32.7	34.9	28.4	29.1	31.0	33.2	26.3	26.9	28.8	30.7	S/T	0.89	0.83	0.68	0.51	0.92	0.86	0.70	0.52	0.94	0.88	0.72	0.54	0.97	0.91	0.74	0.55	1.01	0.95	0.77	0.58	1.02	0.95	0.78	0.58	ΔT	24	23	20	16	25	24	21	16	25	24	21	17	25	24	21	17	25	24	21	16	23	22	19	15	kW	2.48	2.53	2.61	2.69	2.67	2.73	2.81	2.90	2.83	2.89	2.99	3.08	2.98	3.04	3.14	3.24	3.10	3.17	3.27	3.38	3.21	3.28	3.38	3.50	Amps	12.5	12.7	13.0	13.4	13.2	13.5	13.8	14.2	14.1	14.4	14.7	15.2	14.9	15.1	15.5	16.0	15.6	15.9	16.3	16.8	16.4	16.7	17.1	17.7	Hi-PR	247	265	280	292	277	298	315	328	315	339	358	373	359	386	407	425	403	434	458	478	446	480	506	528	Lo-PR	108	115	125	133	114	121	132	141	118	126	138	146	124	132	144	154	130	139	151	161	135	143	157	167
	MBh	34.9	35.6	38.1	40.7	34.0	34.8	37.2	39.7	33.2	34.0	36.3	38.8	32.4	33.1	35.4	37.8	30.8	31.5	33.6	36.0	28.5	29.2	31.2	33.3	S/T	0.92	0.86	0.70	0.52	0.95	0.89	0.73	0.54	0.98	0.92	0.75	0.56	1.00	0.95	0.77	0.58	1.00	0.98	0.80	0.60	1.00	0.99	0.81	0.60	ΔT	24	23	20	16	24	23	20	16	24	23	20	16	24	24	20	16	23	23	20	16	21	22	19	15	kW	2.54	2.60	2.68	2.76	2.73	2.79	2.88	2.97	2.90	2.97	3.06	3.16	3.05	3.12	3.22	3.33	3.18	3.25	3.35	3.47	3.29	3.36	3.47	3.59	Amps	12.7	13.0	13.3	13.7	13.5	13.8	14.1	14.5	14.4	14.7	15.1	15.5	15.2	15.5	15.9	16.4	16.0	16.3	16.7	17.2	16.7	17.1	17.5	18.1	Hi-PR	254	274	289	301	285	307	324	338	325	349	369	385	370	398	420	438	416	448	473	493	460	494	522	545	Lo-PR	111	118	129	138	117	125	136	145	122	130	142	151	128	136	149	159	134	143	156	166	139	148	161	172		MBh	32.2	32.9	35.1	37.5	31.4	32.1	34.3	36.7	30.7	31.3	33.5	35.8	29.9	30.6	32.7	34.9	28.4	29.1	31.0	33.2	26.3	26.9	28.8	30.7	S/T	0.89	0.83	0.68	0.51	0.92	0.86	0.70	0.52	0.94	0.88	0.72	0.54	0.97	0.91	0.74	0.55	1.01	0.95	0.77	0.58	1.02	0.95	0.78	0.58	ΔT	24	23	20	16	25	24	21	16	25	24	21	17	25	24	21	17	25	24	21	16	23	22	19	15	kW	2.48	2.53	2.61	2.69	2.67	2.73	2.81	2.90	2.83	2.89	2.99	3.08	2.98	3.04	3.14	3.24	3.10	3.17	3.27	3.38	3.21	3.28	3.38	3.50	Amps	12.5	12.7	13.0	13.4	13.2	13.5	13.8	14.2	14.1	14.4	14.7	15.2	14.9	15.1	15.5	16.0	15.6	15.9	16.3	16.8	16.4	16.7	17.1	17.7	Hi-PR	247	265	280	292	277	298	315	328	315	339	358	373	359	386	407	425	403	434	458	478	446	480	506	528	Lo-PR	108	115	125	133	114	121	132	141	118	126	138	146	124	132	144	154	130	139	151	161	135	143	157	167																																																																																																																																																																																
	MBh	32.2	32.9	35.1	37.5	31.4	32.1	34.3	36.7	30.7	31.3	33.5	35.8	29.9	30.6	32.7	34.9	28.4	29.1	31.0	33.2	26.3	26.9	28.8	30.7	S/T	0.89	0.83	0.68	0.51	0.92	0.86	0.70	0.52	0.94	0.88	0.72	0.54	0.97	0.91	0.74	0.55	1.01	0.95	0.77	0.58	1.02	0.95	0.78	0.58	ΔT	24	23	20	16	25	24	21	16	25	24	21	17	25	24	21	17	25	24	21	16	23	22	19	15	kW	2.48	2.53	2.61	2.69	2.67	2.73	2.81	2.90	2.83	2.89	2.99	3.08	2.98	3.04	3.14	3.24	3.10	3.17	3.27	3.38	3.21	3.28	3.38	3.50	Amps	12.5	12.7	13.0	13.4	13.2	13.5	13.8	14.2	14.1	14.4	14.7	15.2	14.9	15.1	15.5	16.0	15.6	15.9	16.3	16.8	16.4	16.7	17.1	17.7	Hi-PR	247	265	280	292	277	298	315	328	315	339	358	373	359	386	407	425	403	434	458	478	446	480	506	528	Lo-PR	108	115	125	133	114	121	132	141	118	126	138	146	124	132	144	154	130	139	151	161	135	143	157	167																																																																																																																																																																																																																																																																																																																																																																

	MBh	36.5	37.2	39.0	41.6	35.7	36.4	38.1	40.6	34.8	35.5	37.2	39.7	34.0	34.6	36.3	38.7	32.3	32.9	34.5	36.8	29.9	30.5	31.9	34.1	S/T	1.00	0.98	0.88	0.71	1.00	1.00	0.91	0.74	1.00	1.00	0.94	0.76	1.00	1.00	0.97	0.78	1.00	1.00	1.00	0.81	1.00	1.00	1.00	0.82	ΔT	24	24	23	20	24	24	23	20	23	24	23	20	23	23	23	20	22	22	23	20	20	20	21	19	kW	2.58	2.64	2.72	2.80	2.78	2.84	2.93	3.02	2.95	3.01	3.11	3.21	3.10	3.17	3.27	3.38	3.23	3.30	3.41	3.52	3.34	3.42	3.53	3.65	Amps	12.9	13.2	13.5	13.9	13.7	14.0	14.3	14.7	14.6	14.9	15.3	15.8	15.4	15.7	16.1	16.6	16.2	16.5	17.0	17.5	17.0	17.3	17.8	18.4	Hi-PR	259	279	295	308	291	313	331	345	331	356	376	392	377	406	429	447	424	457	482	503	469	504	533	556	Lo-PR	113	121	132	140	120	127	139	148	125	132	145	154	131	139	152	162	137	146	159	170	142	151	165	175		MBh	35.5	36.2	37.9	40.4	34.6	35.3	37.0	39.5	33.8	34.5	36.1	38.5	33.0	33.6	35.2	37.6	31.3	31.9	33.5	35.7	29.0	29.6	31.0	33.1	S/T	0.96	0.93	0.84	0.68	1.00	0.96	0.87	0.71	1.00	0.99	0.89	0.72	1.00	1.00	0.92	0.75	1.00	1.00	0.96	0.78	1.00	1.00	0.96	0.78	ΔT	26	25	24	21	26	26	24	21	25	26	24	21	25	25	24	21	24	24	24	21	22	22	22	19	kW	2.56	2.62	2.70	2.78	2.76	2.81	2.90	3.00	2.93	2.99	3.08	3.19	3.08	3.14	3.25	3.35	3.20	3.28	3.38	3.49	3.32	3.39	3.50	3.62	Amps	12.8	13.1	13.4	13.8	13.6	13.9	14.2	14.6	14.5	14.8	15.2	15.6	15.3	15.6	16.0	16.5	16.1	16.4	16.8	17.4	16.9	17.2	17.7	18.2	Hi-PR	257	276	292	304	288	310	328	342	328	353	373	389	373	402	424	443	420	452	477	498	464	499	527	550	Lo-PR	112	119	130	139	119	126	138	147	123	131	143	152	130	138	150	160	136	144	158	168	140	149	163	174		MBh	32.7	33.4	34.9	37.3	32.0	32.6	34.1	36.4	31.2	31.8	33.3	35.6	30.5	31.0	32.5	34.7	28.9	29.5	30.9	33.0	26.8	27.3	28.6	30.5	S/T	0.93	0.90	0.81	0.66	0.96	0.93	0.84	0.68	0.99	0.95	0.86	0.70	1.00	0.98	0.89	0.72	1.00	1.00	0.92	0.75	1.00	1.00	0.93	0.75	ΔT	26	26	24	21	26	26	25	21	26	26	25	21	26	26	25	21	25	25	24	21	23	23	23	20	kW	2.50	2.55	2.63	2.72	2.69	2.75	2.83	2.92	2.86	2.92	3.01	3.11	3.00	3.07	3.17	3.27	3.13	3.19	3.30	3.41	3.23	3.30	3.41	3.53	Amps	12.6	12.8	13.1	13.5	13.3	13.6	13.9	14.3	14.2	14.5	14.9	15.3	15.0	15.3	15.7	16.1	15.7	16.0	16.5	17.0	16.5	16.8	17.3	17.8	Hi-PR	249	268	283	295	280	301	318	331	318	342	361	377	362	390	412	429	407	438	463	483	450	484	512	534	Lo-PR	109	116	126	135	115	122	134	142	120	127	139	148	126	134	146	155	132	140	153	163	136	145	158	168
	MBh	35.5	36.2	37.9	40.4	34.6	35.3	37.0	39.5	33.8	34.5	36.1	38.5	33.0	33.6	35.2	37.6	31.3	31.9	33.5	35.7	29.0	29.6	31.0	33.1	S/T	0.96	0.93	0.84	0.68	1.00	0.96	0.87	0.71	1.00	0.99	0.89	0.72	1.00	1.00	0.92	0.75	1.00	1.00	0.96	0.78	1.00	1.00	0.96	0.78	ΔT	26	25	24	21	26	26	24	21	25	26	24	21	25	25	24	21	24	24	24	21	22	22	22	19	kW	2.56	2.62	2.70	2.78	2.76	2.81	2.90	3.00	2.93	2.99	3.08	3.19	3.08	3.14	3.25	3.35	3.20	3.28	3.38	3.49	3.32	3.39	3.50	3.62	Amps	12.8	13.1	13.4	13.8	13.6	13.9	14.2	14.6	14.5	14.8	15.2	15.6	15.3	15.6	16.0	16.5	16.1	16.4	16.8	17.4	16.9	17.2	17.7	18.2	Hi-PR	257	276	292	304	288	310	328	342	328	353	373	389	373	402	424	443	420	452	477	498	464	499	527	550	Lo-PR	112	119	130	139	119	126	138	147	123	131	143	152	130	138	150	160	136	144	158	168	140	149	163	174		MBh	32.7	33.4	34.9	37.3	32.0	32.6	34.1	36.4	31.2	31.8	33.3	35.6	30.5	31.0	32.5	34.7	28.9	29.5	30.9	33.0	26.8	27.3	28.6	30.5	S/T	0.93	0.90	0.81	0.66	0.96	0.93	0.84	0.68	0.99	0.95	0.86	0.70	1.00	0.98	0.89	0.72	1.00	1.00	0.92	0.75	1.00	1.00	0.93	0.75	ΔT	26	26	24	21	26	26	25	21	26	26	25	21	26	26	25	21	25	25	24	21	23	23	23	20	kW	2.50	2.55	2.63	2.72	2.69	2.75	2.83	2.92	2.86	2.92	3.01	3.11	3.00	3.07	3.17	3.27	3.13	3.19	3.30	3.41	3.23	3.30	3.41	3.53	Amps	12.6	12.8	13.1	13.5	13.3	13.6	13.9	14.3	14.2	14.5	14.9	15.3	15.0	15.3	15.7	16.1	15.7	16.0	16.5	17.0	16.5	16.8	17.3	17.8	Hi-PR	249	268	283	295	280	301	318	331	318	342	361	377	362	390	412	429	407	438	463	483	450	484	512	534	Lo-PR	109	116	126	135	115	122	134	142	120	127	139	148	126	134	146	155	132	140	153	163	136	145	158	168																																																																																																																																																																																
	MBh	32.7	33.4	34.9	37.3	32.0	32.6	34.1	36.4	31.2	31.8	33.3	35.6	30.5	31.0	32.5	34.7	28.9	29.5	30.9	33.0	26.8	27.3	28.6	30.5	S/T	0.93	0.90	0.81	0.66	0.96	0.93	0.84	0.68	0.99	0.95	0.86	0.70	1.00	0.98	0.89	0.72	1.00	1.00	0.92	0.75	1.00	1.00	0.93	0.75	ΔT	26	26	24	21	26	26	25	21	26	26	25	21	26	26	25	21	25	25	24	21	23	23	23	20	kW	2.50	2.55	2.63	2.72	2.69	2.75	2.83	2.92	2.86	2.92	3.01	3.11	3.00	3.07	3.17	3.27	3.13	3.19	3.30	3.41	3.23	3.30	3.41	3.53	Amps	12.6	12.8	13.1	13.5	13.3	13.6	13.9	14.3	14.2	14.5	14.9	15.3	15.0	15.3	15.7	16.1	15.7	16.0	16.5	17.0	16.5	16.8	17.3	17.8	Hi-PR	249	268	283	295	280	301	318	331	318	342	361	377	362	390	412	429	407	438	463	483	450	484	512	534	Lo-PR	109	116	126	135	115	122	134	142	120	127	139	148	126	134	146	155	132	140	153	163	136	145	158	168																																																																																																																																																																																																																																																																																																																																																																

Shaded area reflects ARI conditions IDB: Entering Indoor Dry Bulb Temperature kW = Total system power Amps = outdoor unit amps (comp.+fan)
 High and low pressures are measured at the liquid and suction service valves.

EXPANDED COOLING DATA — APG1548***41** — SINGLE STAGE

IDB	Airflow	Outdoor Ambient Temperature																							
		65°F				75°F				85°F				95°F				105°F				115°F			
		59	63	67	71	59	63	67	71	59	63	67	71	59	63	67	71	59	63	67	71	59	63	67	71
1238	MBh	34.3	35.5	38.9	-	33.5	34.7	38.0	-	32.7	33.9	37.1	-	31.9	33.1	36.2	-	30.3	31.4	34.4	-	28.1	29.1	31.9	-
	S/T	0.77	0.65	0.45	-	0.80	0.67	0.46	-	0.82	0.69	0.48	-	0.85	0.71	0.49	-	0.88	0.74	0.51	-	0.89	0.74	0.51	-
	ΔT	20	17	13	-	20	17	13	-	20	17	13	-	20	17	13	-	20	17	13	-	19	16	12	-
	kW	2.31	2.35	2.42	-	2.47	2.52	2.60	-	2.62	2.67	2.76	-	2.75	2.81	2.89	-	2.86	2.92	3.01	-	2.95	3.01	3.11	-
	Amps	10.4	10.6	10.9	-	11.1	11.3	11.6	-	11.9	12.1	12.4	-	12.5	12.8	13.1	-	13.2	13.5	13.8	-	13.8	14.1	14.5	-
	Hi PR	223	240	253	-	250	269	284	-	284	306	323	-	324	349	368	-	364	392	414	-	403	433	458	-
	Lo PR	112	120	131	-	119	126	138	-	123	131	143	-	130	138	151	-	136	145	158	-	141	150	163	-
	MBh	33.3	34.5	37.8	-	32.5	33.7	36.9	-	31.7	32.9	36.1	-	31.0	32.1	35.2	-	29.4	30.5	33.4	-	27.3	28.3	31.0	-
	S/T	0.74	0.62	0.43	-	0.76	0.64	0.44	-	0.78	0.65	0.45	-	0.81	0.68	0.47	-	0.84	0.70	0.49	-	0.85	0.71	0.49	-
	ΔT	21	18	13	-	21	18	14	-	21	18	14	-	21	18	14	-	21	18	14	-	19	17	13	-
70	kW	2.29	2.34	2.41	-	2.46	2.51	2.58	-	2.60	2.65	2.73	-	2.73	2.78	2.87	-	2.84	2.89	2.99	-	2.93	2.99	3.08	-
	Amps	10.3	10.5	10.8	-	11.0	11.2	11.5	-	11.8	12.0	12.3	-	12.4	12.7	13.0	-	13.1	13.4	13.7	-	13.7	14.0	14.4	-
	Hi PR	221	237	251	-	248	266	281	-	282	303	320	-	321	345	365	-	361	388	410	-	399	429	453	-
	Lo PR	111	118	129	-	118	125	137	-	122	130	142	-	128	137	149	-	135	143	156	-	139	148	162	-
	MBh	30.7	31.9	34.9	-	30.0	31.1	34.1	-	29.3	30.4	33.3	-	28.6	29.6	32.5	-	27.2	28.2	30.8	-	25.2	26.1	28.6	-
	S/T	0.71	0.59	0.41	-	0.74	0.62	0.43	-	0.76	0.63	0.44	-	0.78	0.65	0.45	-	0.81	0.68	0.47	-	0.82	0.68	0.47	-
	ΔT	21	18	14	-	21	18	14	-	21	18	14	-	21	18	14	-	21	18	14	-	20	17	13	-
	kW	2.24	2.29	2.35	-	2.40	2.45	2.52	-	2.54	2.59	2.67	-	2.66	2.72	2.80	-	2.77	2.83	2.91	-	2.86	2.92	3.01	-
	Amps	10.1	10.3	10.6	-	10.8	11.0	11.3	-	11.5	11.7	12.0	-	12.1	12.4	12.7	-	12.8	13.0	13.4	-	13.4	13.7	14.1	-
	Hi PR	214	230	243	-	240	258	273	-	273	294	310	-	311	335	354	-	350	377	398	-	387	416	439	-
Lo PR	108	115	125	-	114	121	132	-	119	126	138	-	125	132	145	-	131	139	152	-	135	144	157	-	

1238	MBh	34.9	35.9	38.9	41.7	34.1	35.1	38.0	40.7	33.3	34.2	37.1	39.8	32.4	33.4	36.2	38.8	30.8	31.7	34.4	36.9	28.6	29.4	31.8	34.2
	S/T	0.88	0.79	0.60	0.38	0.91	0.81	0.62	0.40	0.93	0.84	0.63	0.41	0.96	0.86	0.65	0.42	1.00	0.90	0.68	0.44	1.00	0.90	0.68	0.44
	ΔT	23	21	17	12	23	21	17	12	23	21	17	12	23	21	18	12	23	21	17	12	21	20	16	11
	kW	2.33	2.37	2.44	2.52	2.49	2.54	2.62	2.70	2.64	2.69	2.78	2.86	2.77	2.83	2.92	3.01	2.88	2.94	3.03	3.13	2.98	3.04	3.14	3.24
	Amps	10.5	10.7	11.0	11.3	11.2	11.4	11.7	12.0	11.9	12.2	12.5	12.9	12.6	12.9	13.2	13.7	13.3	13.6	13.9	14.4	14.0	14.2	14.7	15.1
	Hi PR	225	242	256	267	253	272	287	299	287	309	327	341	327	352	372	388	368	396	418	436	407	438	462	482
	Lo PR	114	121	132	140	120	128	139	148	125	133	145	154	131	139	152	162	137	146	159	170	142	151	165	176
	MBh	33.9	34.9	37.7	40.5	33.1	34.1	36.9	39.6	32.3	33.2	36.0	38.6	31.5	32.4	35.1	37.7	29.9	30.8	33.3	35.8	27.7	28.5	30.9	33.2
	S/T	0.84	0.75	0.57	0.37	0.87	0.78	0.59	0.38	0.89	0.80	0.60	0.39	0.92	0.82	0.62	0.40	0.95	0.85	0.65	0.42	0.96	0.86	0.65	0.42
	ΔT	24	22	18	12	24	22	18	13	24	22	18	13	24	22	18	13	24	22	18	12	22	21	17	12
75	kW	2.31	2.36	2.42	2.50	2.47	2.52	2.60	2.68	2.62	2.67	2.76	2.84	2.75	2.81	2.89	2.98	2.86	2.92	3.01	3.11	2.95	3.01	3.11	3.21
	Amps	10.4	10.6	10.9	11.2	11.1	11.3	11.6	12.0	11.9	12.1	12.4	12.8	12.5	12.8	13.1	13.5	13.2	13.5	13.8	14.3	13.8	14.1	14.5	15.0
	Hi PR	223	240	253	264	250	269	284	296	285	306	323	337	324	349	368	384	365	392	414	432	403	433	458	477
	Lo PR	112	120	131	139	119	126	138	147	123	131	143	153	130	138	151	160	136	145	158	168	141	150	163	174
	MBh	31.3	32.2	34.8	37.4	30.5	31.4	34.0	36.5	29.8	30.7	33.2	35.6	29.1	29.9	32.4	34.8	27.6	28.4	30.8	33.0	25.6	26.3	28.5	30.6
	S/T	0.81	0.72	0.55	0.35	0.84	0.75	0.57	0.36	0.86	0.77	0.58	0.37	0.89	0.79	0.60	0.39	0.92	0.82	0.62	0.40	0.93	0.83	0.63	0.40
	ΔT	24	22	18	13	24	22	18	13	24	23	18	13	25	23	19	13	24	22	18	13	23	21	17	12
	kW	2.26	2.30	2.37	2.44	2.42	2.47	2.54	2.62	2.56	2.61	2.69	2.77	2.68	2.74	2.82	2.91	2.79	2.85	2.94	3.03	2.88	2.94	3.03	3.13
	Amps	10.2	10.4	10.6	11.0	10.8	11.0	11.3	11.7	11.6	11.8	12.1	12.5	12.2	12.5	12.8	13.2	12.9	13.1	13.5	13.9	13.5	13.8	14.2	14.7
	Hi PR	216	233	246	256	243	261	276	288	276	297	314	327	314	338	357	373	354	381	402	419	391	420	444	463
Lo PR	109	116	127	135	115	123	134	143	120	127	139	148	126	134	146	156	132	140	153	163	136	145	158	169	

Shaded area reflects ACCA (TVA) conditions IDB: Entering Indoor Dry Bulb Temperature kW = Total system power Amps = outdoor unit amps (comp.+fan)
 High and low pressures are measured at the liquid and suction service valves.

EXPANDED COOLING DATA — APG1548***41** — SINGLE STAGE (CONT.)

		Outdoor Ambient Temperature																								
		65°F				75°F				85°F				95°F				105°F				115°F				
		59	63	67	71	59	63	67	71	59	63	67	71	59	63	67	71	59	63	67	71	59	63	67	71	
1238	IDB	Airflow	59	63	67	71	59	63	67	71	59	63	67	71	59	63	67	71	59	63	67	71	59	63	67	71
		MBh	35.5	36.3	38.8	41.4	34.7	35.4	37.9	40.5	33.8	34.6	37.0	39.5	33.0	33.7	36.1	38.5	31.4	32.1	34.2	36.6	29.1	29.7	31.7	33.9
		S/T	0.96	0.90	0.74	0.55	1.00	0.94	0.76	0.57	1.00	0.96	0.78	0.58	1.00	1.00	0.81	0.60	1.00	1.00	0.84	0.63	1.00	1.00	0.84	0.63
		ΔT	25	24	21	17	26	25	21	17	25	25	21	17	25	25	22	17	23	24	21	17	22	22	20	16
		kW	2.34	2.39	2.46	2.54	2.51	2.56	2.64	2.72	2.66	2.72	2.80	2.89	2.79	2.85	2.94	3.03	2.90	2.96	3.06	3.16	3.00	3.06	3.16	3.26
		Amps	10.6	10.8	11.0	11.4	11.2	11.5	11.8	12.1	12.0	12.3	12.6	13.0	12.7	13.0	13.3	13.8	13.4	13.7	14.1	14.5	14.1	14.4	14.8	15.3
		Hi PR	227	245	258	270	255	275	290	302	290	312	330	344	331	356	376	392	372	400	423	441	411	442	467	487
		Lo PR	115	122	133	142	121	129	141	150	126	134	146	156	132	141	154	164	139	148	161	172	143	153	167	177
		MBh	34.5	35.2	37.6	40.2	33.7	34.4	36.8	39.3	32.9	33.6	35.9	38.4	32.1	32.8	35.0	37.4	30.5	31.1	33.3	35.5	28.2	28.8	30.8	32.9
		S/T	0.92	0.86	0.70	0.52	0.95	0.89	0.73	0.54	0.98	0.92	0.75	0.56	1.00	0.95	0.77	0.58	1.00	0.98	0.80	0.60	1.00	0.99	0.81	0.60
		ΔT	26	25	22	18	27	26	22	18	27	26	22	18	27	26	23	18	25	26	22	18	24	24	21	17
		kW	2.33	2.37	2.44	2.52	2.49	2.54	2.62	2.70	2.64	2.69	2.78	2.86	2.77	2.83	2.92	3.01	2.88	2.94	3.03	3.13	2.98	3.04	3.14	3.24
	Amps	10.5	10.7	11.0	11.3	11.2	11.4	11.7	12.0	11.9	12.2	12.5	12.9	12.6	12.9	13.2	13.7	13.3	13.6	14.0	14.4	14.0	14.2	14.7	15.1	
	Hi PR	225	242	256	267	253	272	287	299	287	309	327	341	327	352	372	388	368	396	418	436	407	438	462	482	
	Lo PR	114	121	132	140	120	128	139	148	125	133	145	154	131	139	152	162	137	146	159	170	142	151	165	176	
	MBh	31.8	32.5	34.7	37.1	31.1	31.7	33.9	36.3	30.3	31.0	33.1	35.4	29.6	30.2	32.3	34.5	28.1	28.7	30.7	32.8	26.0	26.6	28.4	30.4	
	S/T	0.89	0.83	0.68	0.51	0.92	0.86	0.70	0.52	0.94	0.88	0.72	0.54	0.97	0.91	0.74	0.55	1.01	0.95	0.77	0.58	1.02	0.95	0.78	0.58	
	ΔT	27	26	22	18	27	26	23	18	27	26	23	18	27	26	23	18	27	26	23	18	25	24	21	17	
	kW	2.28	2.32	2.39	2.46	2.44	2.49	2.56	2.64	2.58	2.63	2.71	2.80	2.71	2.76	2.85	2.94	2.81	2.87	2.96	3.06	2.90	2.97	3.06	3.16	
	Amps	10.3	10.5	10.7	11.0	10.9	11.1	11.4	11.8	11.7	11.9	12.2	12.6	12.3	12.6	12.9	13.3	13.0	13.2	13.6	14.1	13.6	13.9	14.3	14.8	
	Hi PR	218	235	248	259	245	264	279	291	279	300	317	330	317	342	361	376	357	384	406	423	395	425	448	468	
	Lo PR	110	117	128	136	116	124	135	144	121	129	141	150	127	135	148	157	133	142	155	165	138	147	160	170	

1238	IDB	Airflow	59	63	67	71	59	63	67	71	59	63	67	71	59	63	67	71	59	63	67	71	59	63	67	71
		MBh	36.1	36.8	38.6	41.1	35.3	36.0	37.7	40.2	34.4	35.1	36.8	39.2	33.6	34.2	35.9	38.3	31.9	32.5	34.1	36.4	29.6	30.1	31.6	33.7
		S/T	1.00	0.98	0.88	0.71	1.00	1.00	0.91	0.74	1.00	1.00	0.94	0.76	1.00	1.00	0.97	0.78	1.00	1.00	1.00	0.81	1.00	1.00	1.00	0.82
		ΔT	27	27	25	22	26	27	26	22	26	26	26	22	25	25	26	22	24	24	25	22	22	22	22	23
		kW	2.36	2.41	2.48	2.55	2.53	2.58	2.66	2.74	2.68	2.74	2.82	2.91	2.81	2.87	2.96	3.06	2.93	2.99	3.08	3.18	3.02	3.09	3.19	3.29
		Amps	10.6	10.8	11.1	11.5	11.3	11.5	11.9	12.2	12.1	12.4	12.7	13.1	12.8	13.1	13.4	13.9	13.5	13.8	14.2	14.6	14.2	14.5	14.9	15.4
		Hi PR	230	247	261	272	258	277	293	306	293	315	333	347	334	359	379	396	376	404	427	445	415	447	472	492
		Lo PR	116	123	135	143	122	130	142	151	127	135	148	157	134	142	155	165	140	149	163	173	145	154	168	179
		MBh	35.1	35.7	37.4	39.9	34.3	34.9	36.6	39.0	33.4	34.1	35.7	38.1	32.6	33.3	34.8	37.2	31.0	31.6	33.1	35.3	28.7	29.3	30.6	32.7
		S/T	0.96	0.93	0.84	0.68	1.00	0.96	0.87	0.71	1.00	0.99	0.89	0.72	1.00	1.00	0.92	0.75	1.00	1.00	0.96	0.78	1.00	1.00	0.96	0.78
		ΔT	28	28	26	23	29	29	27	23	28	28	27	23	27	28	27	23	26	26	26	23	24	24	25	21
		kW	2.34	2.39	2.46	2.54	2.51	2.56	2.64	2.72	2.66	2.72	2.80	2.89	2.79	2.85	2.94	3.03	2.90	2.96	3.06	3.16	3.00	3.06	3.16	3.26
	Amps	10.6	10.8	11.0	11.4	11.2	11.5	11.8	12.1	12.0	12.3	12.6	13.0	12.7	13.0	13.3	13.8	13.4	13.7	14.1	14.5	14.1	14.4	14.8	15.3	
	Hi PR	227	245	258	270	255	275	290	302	290	312	330	344	331	356	376	392	372	400	423	441	411	442	467	487	
	Lo PR	115	122	133	142	121	129	141	150	126	134	146	156	132	141	154	164	139	148	161	172	143	153	167	177	
	MBh	32.4	33.0	34.6	36.9	31.6	32.2	33.8	36.0	30.9	31.5	32.9	35.1	30.1	30.7	32.1	34.3	28.6	29.2	30.5	32.6	26.5	27.0	28.3	30.2	
	S/T	0.93	0.90	0.81	0.66	0.96	0.93	0.84	0.68	0.99	0.95	0.86	0.70	1.00	0.98	0.89	0.72	1.00	1.00	0.92	0.75	1.00	1.00	0.93	0.75	
	ΔT	29	28	27	23	29	29	27	23	29	29	27	23	29	29	27	23	27	28	27	23	25	26	25	22	
	kW	2.29	2.34	2.41	2.48	2.46	2.50	2.58	2.66	2.60	2.65	2.73	2.82	2.73	2.78	2.87	2.96	2.83	2.89	2.98	3.08	2.93	2.99	3.08	3.18	
	Amps	10.3	10.5	10.8	11.1	11.0	11.2	11.5	11.9	11.8	12.0	12.3	12.7	12.4	12.7	13.0	13.4	13.1	13.4	13.7	14.2	13.7	14.0	14.4	14.9	
	Hi PR	221	237	251	261	248	266	281	293	282	303	320	334	321	345	364	380	361	388	410	428	399	429	453	472	
	Lo PR	111	118	129	138	118	125	137	145	122	130	142	151	128	137	149	159	135	143	156	166	139	148	162	172	

Shaded area reflects ARI conditions IDB: Entering Indoor Dry Bulb Temperature kW = Total system power Amps = outdoor unit amps (comp.+fan)
 High and low pressures are measured at the liquid and suction service valves.

EXPANDED COOLING DATA — APG1548***41** — Two Stage

IDB	Airflow	Outdoor Ambient Temperature																							
		65°F				75°F				85°F				95°F				105°F				115°F			
		59	63	67	71	59	63	67	71	59	63	67	71	59	63	67	71	59	63	67	71	59	63	67	71
1699	MBh	46.5	48.2	52.9	-	45.5	47.1	51.6	-	44.4	46.0	50.4	-	43.3	44.9	49.2	-	41.1	42.6	46.7	-	38.1	39.5	43.3	-
	S/T	0.77	0.65	0.45	-	0.80	0.67	0.46	-	0.82	0.69	0.48	-	0.85	0.71	0.49	-	0.88	0.74	0.51	-	0.89	0.74	0.51	-
	ΔT	19	17	13	-	20	17	13	-	20	17	13	-	20	17	13	-	20	17	13	-	18	16	12	-
	kW	3.43	3.50	3.60	-	3.67	3.75	3.86	-	3.89	3.97	4.08	-	4.07	4.16	4.28	-	4.23	4.32	4.45	-	4.37	4.46	4.60	-
	Amps	15.9	16.2	16.6	-	16.9	17.2	17.7	-	18.0	18.4	18.9	-	19.0	19.4	19.9	-	20.0	20.4	20.9	-	20.9	21.4	22.0	-
	Hi PR	244	262	277	-	273	294	311	-	311	334	353	-	354	381	402	-	398	429	453	-	440	473	500	-
	Lo PR	111	118	129	-	117	124	136	-	122	129	141	-	128	136	148	-	134	142	156	-	138	147	161	-
	MBh	45.2	46.8	51.3	-	44.1	45.7	50.1	-	43.1	44.7	48.9	-	42.0	43.6	47.7	-	39.9	41.4	45.4	-	37.0	38.3	42.0	-
	S/T	0.74	0.62	0.43	-	0.76	0.64	0.44	-	0.78	0.65	0.45	-	0.81	0.68	0.47	-	0.84	0.70	0.49	-	0.85	0.71	0.49	-
	ΔT	20	18	13	-	21	18	13	-	21	18	14	-	21	18	14	-	20	18	13	-	19	17	13	-
70	kW	3.41	3.48	3.58	-	3.65	3.72	3.83	-	3.86	3.94	4.05	-	4.04	4.13	4.25	-	4.20	4.29	4.42	-	4.34	4.43	4.57	-
	Amps	15.8	16.1	16.5	-	16.8	17.1	17.5	-	17.9	18.2	18.7	-	18.9	19.2	19.8	-	19.8	20.2	20.8	-	20.8	21.2	21.8	-
	Hi PR	241	259	274	-	271	291	307	-	308	331	350	-	350	377	398	-	394	424	448	-	436	469	495	-
	Lo PR	110	117	127	-	116	123	135	-	120	128	140	-	126	135	147	-	133	141	154	-	137	146	159	-
	MBh	41.7	43.2	47.4	-	40.7	42.2	46.3	-	39.8	41.2	45.2	-	38.8	40.2	44.1	-	36.9	38.2	41.9	-	34.1	35.4	38.8	-
	S/T	0.71	0.59	0.41	-	0.74	0.62	0.43	-	0.76	0.63	0.44	-	0.78	0.65	0.45	-	0.81	0.68	0.47	-	0.82	0.68	0.47	-
	ΔT	21	18	14	-	21	18	14	-	21	18	14	-	21	18	14	-	21	18	14	-	19	17	13	-
	kW	3.34	3.40	3.50	-	3.57	3.64	3.74	-	3.77	3.85	3.96	-	3.95	4.03	4.15	-	4.10	4.19	4.32	-	4.24	4.32	4.46	-
	Amps	15.5	15.8	16.2	-	16.4	16.7	17.2	-	17.5	17.9	18.3	-	18.5	18.8	19.3	-	19.4	19.8	20.3	-	20.3	20.7	21.3	-
	Hi PR	234	252	266	-	262	282	298	-	298	321	339	-	340	366	386	-	382	412	435	-	423	455	480	-
Lo PR	106	113	124	-	112	120	131	-	117	124	136	-	123	131	143	-	129	137	149	-	133	141	154	-	

1699	MBh	47.3	48.7	52.8	56.6	46.2	47.6	51.5	55.3	45.1	46.5	50.3	54.0	44.0	45.3	49.1	52.7	41.8	43.1	46.6	50.0	38.7	39.9	43.2	46.3
	S/T	0.88	0.79	0.60	0.38	0.91	0.81	0.62	0.40	0.93	0.84	0.63	0.41	0.96	0.86	0.65	0.42	1.00	0.90	0.68	0.44	1.00	0.90	0.68	0.44
	ΔT	23	21	17	12	23	21	17	12	23	21	17	12	23	21	17	12	23	21	17	12	21	19	16	11
	kW	3.46	3.53	3.63	3.74	3.70	3.78	3.89	4.01	3.92	4.00	4.12	4.24	4.11	4.19	4.32	4.45	4.27	4.36	4.49	4.63	4.41	4.50	4.64	4.79
	Amps	16.0	16.3	16.7	17.2	17.0	17.3	17.8	18.3	18.2	18.5	19.0	19.6	19.2	19.5	20.0	20.7	20.1	20.5	21.1	21.7	21.1	21.5	22.1	22.8
	Hi PR	246	265	280	292	276	297	314	327	314	338	357	372	358	385	406	424	402	433	457	477	444	478	505	527
	Lo PR	112	119	130	138	118	126	137	146	123	131	143	152	129	137	150	160	135	144	157	167	140	149	162	173
	MBh	46.0	47.3	51.2	55.0	44.9	46.2	50.0	53.7	43.8	45.1	48.8	52.4	42.8	44.0	47.6	51.1	40.6	41.8	45.3	48.6	37.6	38.7	41.9	45.0
	S/T	0.84	0.75	0.57	0.37	0.87	0.78	0.59	0.38	0.89	0.80	0.60	0.39	0.92	0.82	0.62	0.40	0.95	0.85	0.65	0.42	0.96	0.86	0.65	0.42
	ΔT	23	22	18	12	24	22	18	12	24	22	18	12	24	22	18	12	24	22	18	12	22	20	17	11
75	kW	3.43	3.50	3.60	3.71	3.68	3.75	3.86	3.97	3.89	3.97	4.09	4.21	4.08	4.16	4.29	4.42	4.23	4.32	4.46	4.60	4.37	4.46	4.60	4.75
	Amps	15.9	16.2	16.6	17.1	16.9	17.2	17.7	18.2	18.0	18.4	18.9	19.4	19.0	19.4	19.9	20.5	20.0	20.4	20.9	21.6	20.9	21.4	22.0	22.6
	Hi PR	244	262	277	289	273	294	311	324	311	335	353	368	354	381	402	420	398	429	453	472	440	474	500	522
	Lo PR	111	118	129	137	117	125	136	145	122	129	141	150	128	136	148	158	134	142	156	166	139	147	161	171
	MBh	42.4	43.7	47.3	50.7	41.4	42.7	46.2	49.6	40.4	41.6	45.1	48.4	39.5	40.6	44.0	47.2	37.5	38.6	41.8	44.8	34.7	35.8	38.7	41.5
	S/T	0.81	0.72	0.55	0.35	0.84	0.75	0.57	0.36	0.86	0.77	0.58	0.37	0.89	0.79	0.60	0.39	0.92	0.82	0.62	0.40	0.93	0.83	0.63	0.40
	ΔT	24	22	18	12	24	22	18	13	24	22	18	13	24	22	18	13	24	22	18	13	22	21	17	12
	kW	3.36	3.42	3.52	3.63	3.59	3.66	3.77	3.88	3.80	3.88	3.99	4.11	3.98	4.06	4.19	4.31	4.14	4.22	4.35	4.49	4.27	4.36	4.49	4.63
	Amps	15.6	15.9	16.3	16.7	16.6	16.9	17.3	17.8	17.7	18.0	18.5	19.0	18.6	19.0	19.5	20.0	19.5	19.9	20.5	21.1	20.5	20.9	21.5	22.1
	Hi PR	236	254	268	280	265	285	301	314	302	324	343	357	343	370	390	407	386	416	439	458	427	459	485	506
Lo PR	107	114	125	133	114	121	132	140	118	126	137	146	124	132	144	153	130	138	151	161	134	143	156	166	

Shaded area reflects ACCA (TVA) conditions IDB: Entering Indoor Dry Bulb Temperature kW = Total system power Amps = outdoor unit amps (comp. +fan)
 High and low pressures are measured at the liquid and suction service valves.

EXPANDED COOLING DATA — APG1548***41** — Two Stage (CONT.)

IDB	Airflow	Outdoor Ambient Temperature																							
		65°F				75°F				85°F				95°F				105°F				115°F			
		59	63	67	71	59	63	67	71	59	63	67	71	59	63	67	71	59	63	67	71	59	63	67	71
80	MBh	48.2	49.2	52.6	56.2	47.1	48.1	51.4	54.9	45.9	46.9	50.1	53.6	44.8	45.8	48.9	52.3	42.6	43.5	46.5	49.7	39.4	40.3	43.1	46.0
	S/T	0.96	0.90	0.74	0.55	1.00	0.94	0.76	0.57	1.00	0.96	0.78	0.58	1.00	0.90	0.81	0.60	1.00	1.00	0.84	0.63	1.00	1.00	0.84	0.63
	ΔT	25	24	21	17	25	24	21	17	24	25	21	17	24	25	21	17	23	24	21	17	21	22	20	16
	kW	3.48	3.55	3.66	3.76	3.73	3.80	3.92	4.04	3.95	4.03	4.15	4.28	4.14	4.22	4.35	4.49	4.30	4.39	4.53	4.67	4.44	4.53	4.68	4.82
	Amps	16.2	16.5	16.9	17.3	17.2	17.5	17.9	18.4	18.3	18.7	19.1	19.7	19.3	19.7	20.2	20.8	20.3	20.7	21.3	21.9	21.3	21.7	22.3	23.0
	Hi PR	249	267	282	295	279	300	317	330	317	341	360	376	361	389	410	428	406	437	462	482	449	483	510	532
	Lo PR	113	120	131	140	119	127	139	148	124	132	144	154	130	139	151	161	137	145	159	169	141	150	164	175
	MBh	46.8	47.8	51.1	54.6	45.7	46.7	49.9	53.3	44.6	45.6	48.7	52.0	43.5	44.5	47.5	50.8	41.3	42.2	45.1	48.2	38.3	39.1	41.8	44.7
	S/T	0.92	0.86	0.70	0.52	0.95	0.89	0.73	0.54	0.98	0.92	0.75	0.56	1.00	0.95	0.77	0.58	1.00	0.98	0.80	0.60	1.00	0.99	0.81	0.60
	ΔT	26	25	22	17	27	25	22	18	27	25	22	18	26	26	22	18	25	25	22	18	23	24	21	16
kW	3.46	3.53	3.63	3.74	3.70	3.78	3.89	4.01	3.92	4.00	4.12	4.24	4.11	4.19	4.32	4.45	4.27	4.36	4.49	4.63	4.41	4.50	4.64	4.79	
Amps	16.0	16.3	16.7	17.2	17.0	17.3	17.8	18.3	18.2	18.5	19.0	19.6	19.2	19.5	20.0	20.7	20.1	20.5	21.1	21.8	21.1	21.5	22.1	22.8	
Hi PR	246	265	280	292	276	297	314	327	314	338	357	372	358	385	406	424	402	433	457	477	445	478	505	527	
Lo PR	112	119	130	138	118	126	137	146	123	131	143	152	129	137	150	160	135	144	157	167	140	149	163	173	
MBh	43.2	44.1	47.1	50.4	42.2	43.1	46.0	49.2	41.2	42.1	44.9	48.0	40.2	41.0	43.8	46.9	38.2	39.0	41.7	44.5	35.3	36.1	38.6	41.2	
S/T	0.89	0.83	0.68	0.51	0.92	0.86	0.70	0.52	0.94	0.88	0.72	0.54	0.97	0.91	0.74	0.55	1.01	0.95	0.77	0.58	1.02	0.95	0.78	0.58	
ΔT	27	26	22	18	27	26	22	18	27	26	22	18	27	26	23	18	27	26	22	18	25	24	21	17	
kW	3.38	3.45	3.55	3.65	3.62	3.69	3.80	3.91	3.83	3.91	4.02	4.14	4.01	4.09	4.22	4.35	4.17	4.25	4.38	4.52	4.30	4.39	4.53	4.67	
Amps	15.7	16.0	16.4	16.9	16.7	17.0	17.4	17.9	17.8	18.1	18.6	19.1	18.7	19.1	19.6	20.2	19.7	20.1	20.6	21.3	20.6	21.0	21.6	22.3	
Hi PR	239	257	271	283	268	288	304	317	305	328	346	361	347	373	394	411	390	420	443	463	431	464	490	511	
Lo PR	109	115	126	134	115	122	133	142	119	127	138	147	125	133	145	155	131	140	152	162	136	144	158	168	

85	MBh	49.0	50.0	52.3	55.8	47.9	48.8	51.1	54.5	46.7	47.6	49.9	53.2	45.6	46.5	48.7	51.9	43.3	44.2	46.2	49.3	40.1	40.9	42.8	45.7
	S/T	1.00	0.98	0.88	0.71	1.00	1.00	0.91	0.74	1.00	1.00	0.94	0.76	1.00	1.00	0.97	0.78	1.00	1.00	0.96	0.81	1.00	1.00	0.96	0.82
	ΔT	27	26	25	22	26	26	25	22	25	26	25	22	25	25	25	22	23	24	25	22	22	22	23	20
	kW	3.51	3.58	3.68	3.79	3.76	3.83	3.95	4.07	3.98	4.06	4.18	4.31	4.17	4.26	4.39	4.52	4.33	4.42	4.56	4.71	4.48	4.57	4.71	4.86
	Amps	16.3	16.6	17.0	17.5	17.3	17.6	18.0	18.6	18.4	18.8	19.3	19.9	19.4	19.8	20.3	21.0	20.4	20.8	21.4	22.1	21.4	21.9	22.5	23.2
	Hi PR	251	270	285	297	282	303	320	334	320	345	364	380	365	393	415	432	410	442	466	486	453	488	515	537
	Lo PR	114	121	133	141	121	128	140	149	125	133	146	155	132	140	153	163	138	147	160	171	143	152	166	177
	MBh	47.6	48.5	50.8	54.2	46.5	47.4	49.6	52.9	45.4	46.3	48.4	51.7	44.3	45.1	47.3	50.4	42.1	42.9	44.9	47.9	39.0	39.7	41.6	44.4
	S/T	0.96	0.93	0.84	0.68	1.00	0.96	0.87	0.71	1.00	0.99	0.89	0.72	1.00	1.00	0.92	0.75	1.00	1.00	0.96	0.78	1.00	1.00	0.96	0.78
	ΔT	28	27	26	22	28	28	26	23	28	28	26	23	27	27	26	23	26	26	26	23	24	24	24	21
kW	3.48	3.55	3.66	3.76	3.73	3.80	3.92	4.04	3.95	4.03	4.15	4.28	4.14	4.22	4.35	4.49	4.30	4.39	4.53	4.67	4.44	4.53	4.68	4.82	
Amps	16.2	16.5	16.9	17.3	17.2	17.5	17.9	18.4	18.3	18.7	19.1	19.7	19.3	19.7	20.2	20.8	20.3	20.7	21.3	21.9	21.3	21.7	22.3	23.0	
Hi PR	249	267	282	295	279	300	317	330	317	341	360	376	361	389	410	428	406	437	462	482	449	483	510	532	
Lo PR	113	120	131	140	119	127	139	148	124	132	144	154	130	139	151	161	137	145	159	169	141	150	164	175	
MBh	43.9	44.8	46.9	50.0	42.9	43.7	45.8	48.9	41.9	42.7	44.7	47.7	40.9	41.7	43.6	46.5	38.8	39.6	41.4	44.2	36.0	36.7	38.4	41.0	
S/T	0.93	0.90	0.81	0.66	0.96	0.93	0.84	0.68	0.99	0.95	0.86	0.70	1.00	0.98	0.89	0.72	1.00	1.00	0.92	0.75	1.00	1.00	0.93	0.75	
ΔT	28	28	26	23	29	28	27	23	29	28	27	23	28	29	27	23	27	28	27	23	27	26	25	21	
kW	3.41	3.47	3.57	3.68	3.65	3.72	3.83	3.94	3.86	3.93	4.05	4.18	4.04	4.13	4.25	4.38	4.20	4.29	4.42	4.56	4.34	4.43	4.56	4.71	
Amps	15.8	16.1	16.5	17.0	16.8	17.1	17.5	18.0	17.9	18.2	18.7	19.3	18.9	19.2	19.7	20.3	19.8	20.2	20.8	21.4	20.8	21.2	21.8	22.5	
Hi PR	241	259	274	286	270	291	307	321	308	331	350	365	350	377	398	415	394	424	448	467	436	469	495	516	
Lo PR	110	117	127	136	116	123	135	143	120	128	140	149	126	135	147	156	133	141	154	164	137	146	159	170	

Shaded area reflects ARI conditions IDB: Entering Indoor Dry Bulb Temperature kW = Total system power Amps = outdoor unit amps (comp. +fan)
 High and low pressures are measured at the liquid and suction service valves.

EXPANDED COOLING DATA — APG1560***41** — SINGLE STAGE

IDB	Airflow	Outdoor Ambient Temperature																							
		65°F				75°F				85°F				95°F				105°F				115°F			
		59	63	67	71	59	63	67	71	59	63	67	71	59	63	67	71	59	63	67	71	59	63	67	71
70	MBh	40.2	41.6	45.6	-	39.2	40.7	44.6	-	38.3	39.7	43.5	-	37.4	38.7	42.4	-	35.5	36.8	40.3	-	32.9	34.1	37.3	-
	S/T	0.77	0.65	0.45	-	0.80	0.67	0.46	-	0.82	0.69	0.48	-	0.85	0.71	0.49	-	0.88	0.74	0.51	-	0.89	0.74	0.51	-
	ΔT	20	17	13	-	20	17	13	-	20	17	13	-	20	17	13	-	20	17	13	-	18	16	12	-
	kW	2.88	2.94	3.03	-	3.09	3.16	3.25	-	3.28	3.35	3.45	-	3.44	3.52	3.63	-	3.59	3.66	3.78	-	3.71	3.79	3.91	-
	Amps	13.6	13.9	14.2	-	14.5	14.7	15.1	-	15.4	15.7	16.2	-	16.3	16.6	17.1	-	17.1	17.5	18.0	-	18.0	18.3	18.8	-
	Hi PR	231	248	262	-	259	279	294	-	294	317	335	-	335	361	381	-	377	406	429	-	417	449	474	-
	Lo PR	111	118	129	-	117	125	136	-	122	129	141	-	128	136	148	-	134	143	156	-	139	147	161	-
	MBh	39.0	40.4	44.3	-	38.1	39.5	43.3	-	37.2	38.5	42.2	-	36.3	37.6	41.2	-	34.5	35.7	39.1	-	31.9	33.1	36.3	-
	S/T	0.74	0.62	0.43	-	0.76	0.64	0.44	-	0.78	0.65	0.45	-	0.81	0.68	0.47	-	0.84	0.70	0.49	-	0.85	0.71	0.49	-
	ΔT	20	18	13	-	21	18	14	-	21	18	14	-	21	18	14	-	20	18	13	-	19	17	13	-
1463	kW	2.86	2.92	3.00	-	3.07	3.13	3.23	-	3.25	3.32	3.43	-	3.42	3.49	3.60	-	3.56	3.63	3.75	-	3.68	3.76	3.88	-
	Amps	13.5	13.8	14.1	-	14.4	14.6	15.0	-	15.3	15.6	16.0	-	16.2	16.5	16.9	-	17.0	17.3	17.8	-	17.8	18.2	18.7	-
	Hi PR	228	246	260	-	256	276	291	-	292	314	331	-	332	357	377	-	374	402	424	-	413	444	469	-
	Lo PR	110	117	127	-	116	123	135	-	120	128	140	-	127	135	147	-	133	141	154	-	137	146	159	-
	MBh	36.0	37.3	40.9	-	35.2	36.4	39.9	-	34.3	35.6	39.0	-	33.5	34.7	38.0	-	31.8	33.0	36.1	-	29.5	30.5	33.5	-
	S/T	0.71	0.59	0.41	-	0.74	0.62	0.43	-	0.76	0.63	0.44	-	0.78	0.65	0.45	-	0.81	0.68	0.47	-	0.82	0.68	0.47	-
	ΔT	21	18	14	-	21	18	14	-	21	18	14	-	21	18	14	-	21	18	14	-	19	17	13	-
	kW	2.79	2.85	2.93	-	3.00	3.06	3.15	-	3.18	3.24	3.34	-	3.34	3.41	3.51	-	3.47	3.55	3.66	-	3.59	3.67	3.78	-
	Amps	13.2	13.5	13.8	-	14.1	14.3	14.7	-	15.0	15.3	15.7	-	15.8	16.1	16.5	-	16.6	17.0	17.4	-	17.4	17.8	18.3	-
	Hi PR	222	238	252	-	249	268	283	-	283	304	321	-	322	347	366	-	362	390	412	-	400	431	455	-
Lo PR	106	113	124	-	112	120	131	-	117	124	136	-	123	131	143	-	129	137	149	-	133	142	155	-	

75	MBh	40.9	42.1	45.5	48.9	39.9	41.1	44.5	47.7	39.0	40.1	43.4	46.6	38.0	39.1	42.4	45.5	36.1	37.2	40.2	43.2	33.4	34.4	37.3	40.0
	S/T	0.88	0.79	0.60	0.38	0.91	0.81	0.62	0.40	0.93	0.84	0.63	0.41	0.96	0.86	0.65	0.42	1.00	0.90	0.68	0.44	1.00	0.90	0.68	0.44
	ΔT	23	21	17	12	23	21	17	12	23	21	17	12	23	21	17	12	23	21	17	12	21	20	16	11
	kW	2.90	2.96	3.05	3.15	3.12	3.18	3.28	3.38	3.31	3.38	3.48	3.59	3.47	3.55	3.66	3.78	3.62	3.69	3.81	3.94	3.74	3.82	3.94	4.07
	Amps	13.7	14.0	14.3	14.7	14.6	14.8	15.2	15.7	15.6	15.9	16.3	16.8	16.4	16.7	17.2	17.7	17.3	17.6	18.1	18.7	18.1	18.5	19.0	19.6
	Hi PR	233	251	265	276	262	281	297	310	297	320	338	353	339	365	385	402	381	410	433	452	421	453	479	499
	Lo PR	112	119	130	138	118	126	137	146	123	131	143	152	129	137	150	160	135	144	157	167	140	149	163	173
	MBh	39.7	40.8	44.2	47.4	38.7	39.9	43.2	46.3	37.8	38.9	42.2	45.2	36.9	38.0	41.1	44.1	35.1	36.1	39.1	41.9	32.5	33.4	36.2	38.8
	S/T	0.84	0.75	0.57	0.37	0.87	0.78	0.59	0.38	0.89	0.80	0.60	0.39	0.92	0.82	0.62	0.40	0.95	0.85	0.65	0.42	0.96	0.86	0.65	0.42
	ΔT	24	22	18	12	24	22	18	12	24	22	18	12	24	22	18	13	24	22	18	12	22	20	17	12
1463	kW	2.88	2.94	3.03	3.12	3.09	3.16	3.25	3.36	3.28	3.35	3.45	3.57	3.45	3.52	3.63	3.75	3.59	3.66	3.78	3.91	3.71	3.79	3.91	4.04
	Amps	13.6	13.9	14.2	14.6	14.5	14.7	15.1	15.6	15.4	15.7	16.2	16.6	16.3	16.6	17.1	17.6	17.1	17.5	18.0	18.5	18.0	18.3	18.8	19.4
	Hi PR	231	248	262	274	259	279	294	307	294	317	335	349	335	361	381	398	377	406	429	447	417	449	474	494
	Lo PR	111	118	129	137	117	125	136	145	122	129	141	151	128	136	149	158	134	143	156	166	139	147	161	171
	MBh	36.6	37.7	40.8	43.8	35.8	36.8	39.9	42.8	34.9	35.9	38.9	41.8	34.1	35.1	38.0	40.7	32.4	33.3	36.1	38.7	30.0	30.9	33.4	35.8
	S/T	0.81	0.72	0.55	0.35	0.84	0.75	0.57	0.36	0.86	0.77	0.58	0.37	0.89	0.79	0.60	0.39	0.92	0.82	0.62	0.40	0.93	0.83	0.63	0.40
	ΔT	24	22	18	12	24	22	18	13	24	22	18	13	24	22	18	13	24	22	18	13	22	21	17	12
	kW	2.81	2.87	2.96	3.05	3.02	3.08	3.18	3.28	3.20	3.27	3.37	3.48	3.36	3.43	3.54	3.66	3.50	3.57	3.69	3.81	3.62	3.70	3.81	3.94
	Amps	13.3	13.6	13.9	14.3	14.2	14.4	14.8	15.2	15.1	15.4	15.8	16.3	15.9	16.2	16.7	17.2	16.7	17.1	17.5	18.1	17.6	17.9	18.4	19.0
	Hi PR	224	241	254	265	251	270	285	298	286	307	325	339	325	350	370	386	366	394	416	434	404	435	460	479
Lo PR	108	114	125	133	114	121	132	141	118	126	137	146	124	132	144	153	130	138	151	161	134	143	156	166	

Shaded area reflects ACCA (TVA) conditions IDB: Entering Indoor Dry Bulb Temperature kW = Total system power Amps = outdoor unit amps (comp. +fan)
 High and low pressures are measured at the liquid and suction service valves.

EXPANDED COOLING DATA — APG1560***41** — SINGLE STAGE (CONT.)

IDB	Airflow	Outdoor Ambient Temperature																							
		65°F				75°F				85°F				105°F				115°F							
		59	63	67	71	59	63	67	71	59	63	67	71	59	63	67	71	59	63	67	71				
80	MBh	41.6	42.5	45.4	48.5	40.6	41.5	44.3	47.4	39.6	40.5	43.3	46.3	38.7	39.5	42.2	45.1	36.7	37.6	40.1	42.9	34.0	34.8	37.2	39.7
	S/T	0.96	0.90	0.74	0.55	1.00	0.94	0.76	0.57	1.00	0.96	0.78	0.58	1.00	1.00	0.81	0.60	1.00	1.00	0.84	0.63	1.00	1.00	0.84	0.63
	ΔT	25	24	21	17	26	24	21	17	25	24	21	17	24	25	21	17	23	24	21	17	21	22	20	16
	kW	2.92	2.98	3.07	3.17	3.14	3.21	3.31	3.41	3.33	3.40	3.51	3.62	3.50	3.58	3.69	3.81	3.65	3.72	3.84	3.97	3.77	3.85	3.98	4.11
	Amps	13.8	14.1	14.4	14.8	14.7	14.9	15.3	15.8	15.7	16.0	16.4	16.9	16.5	16.9	17.3	17.9	17.4	17.7	18.2	18.8	18.2	18.6	19.1	19.8
	Hi-PR	235	253	268	279	264	284	300	313	300	323	341	356	342	368	389	406	385	414	437	456	425	458	483	504
	Lo-PR	113	120	131	140	119	127	139	148	124	132	144	154	130	139	152	161	137	145	159	169	141	150	164	175
	MBh	40.4	41.3	44.1	47.1	39.4	40.3	43.1	46.0	38.5	39.3	42.0	44.9	37.6	38.4	41.0	43.8	35.7	36.5	39.0	41.6	33.0	33.8	36.1	38.6
	S/T	0.92	0.86	0.70	0.52	0.95	0.89	0.73	0.54	0.98	0.92	0.75	0.56	1.00	0.95	0.77	0.58	1.00	0.98	0.80	0.60	1.00	0.99	0.81	0.60
	ΔT	26	25	22	17	27	25	22	18	27	25	22	18	27	26	22	18	25	25	22	18	23	24	21	16
kW	2.90	2.96	3.05	3.15	3.12	3.18	3.28	3.38	3.31	3.38	3.48	3.59	3.47	3.55	3.66	3.78	3.62	3.69	3.81	3.94	3.74	3.82	3.94	4.07	
Amps	13.7	14.0	14.3	14.7	14.6	14.8	15.2	15.7	15.6	15.9	16.3	16.8	16.4	16.7	17.2	17.7	17.3	17.6	18.1	18.7	18.1	18.5	19.0	19.6	
Hi-PR	233	251	265	276	262	281	297	310	297	320	338	353	339	365	385	402	381	410	433	452	421	453	479	499	
Lo-PR	112	119	130	139	118	126	137	146	123	131	143	152	129	137	150	160	135	144	157	167	140	149	163	173	
MBh	37.3	38.1	40.7	43.5	36.4	37.2	39.7	42.5	35.5	36.3	38.8	41.5	34.7	35.4	37.8	40.5	32.9	33.6	36.0	38.4	30.5	31.2	33.3	35.6	
S/T	0.89	0.83	0.68	0.51	0.92	0.86	0.70	0.52	0.94	0.88	0.72	0.54	0.97	0.91	0.74	0.55	1.01	0.95	0.77	0.58	1.02	0.95	0.78	0.58	
ΔT	27	26	22	18	27	26	23	18	27	26	23	18	27	26	23	18	27	26	22	18	25	24	21	17	
kW	2.84	2.89	2.98	3.07	3.04	3.11	3.20	3.30	3.23	3.30	3.40	3.51	3.39	3.46	3.57	3.69	3.53	3.60	3.72	3.84	3.65	3.73	3.85	3.97	
Amps	13.4	13.7	14.0	14.4	14.3	14.5	14.9	15.3	15.2	15.5	15.9	16.4	16.0	16.4	16.8	17.3	16.9	17.2	17.7	18.2	17.7	18.1	18.6	19.1	
Hi-PR	226	243	257	268	254	273	288	301	289	311	328	342	329	354	373	390	370	398	420	438	408	440	464	484	
Lo-PR	109	116	126	134	115	122	133	142	119	127	139	148	125	133	146	155	131	140	152	162	136	144	158	168	

85	MBh	42.3	43.1	45.2	48.2	41.3	42.1	44.1	47.1	40.3	41.1	43.1	45.9	39.4	40.1	42.0	44.8	37.4	38.1	39.9	42.6	34.6	35.3	37.0	39.4
	S/T	1.00	0.98	0.88	0.71	1.00	1.00	0.91	0.74	1.00	1.00	0.94	0.76	1.00	1.00	0.97	0.78	1.00	1.00	1.00	0.81	1.00	1.00	1.00	0.82
	ΔT	27	26	25	22	26	26	25	22	25	26	25	22	25	25	26	22	24	24	25	22	22	22	23	20
	kW	2.95	3.01	3.10	3.19	3.17	3.23	3.33	3.44	3.36	3.43	3.54	3.65	3.53	3.61	3.72	3.84	3.67	3.75	3.88	4.00	3.80	3.88	4.01	4.14
	Amps	13.9	14.2	14.5	14.9	14.8	15.1	15.4	15.9	15.8	16.1	16.5	17.0	16.7	17.0	17.5	18.0	17.5	17.9	18.4	19.0	18.4	18.8	19.3	19.9
	Hi-PR	238	256	270	282	267	287	303	316	303	327	345	360	346	372	393	410	389	418	442	461	430	462	488	509
	Lo-PR	114	122	133	141	121	128	140	149	125	133	146	155	132	140	153	163	138	147	160	171	143	152	166	177
	MBh	41.1	41.9	43.9	46.8	40.1	40.9	42.8	45.7	39.2	39.9	41.8	44.6	38.2	39.0	40.8	43.5	36.3	37.0	38.8	41.3	33.6	34.3	35.9	38.3
	S/T	0.96	0.93	0.84	0.68	1.00	0.96	0.87	0.71	1.00	0.99	0.89	0.72	1.00	1.00	0.92	0.75	1.00	1.00	0.96	0.78	1.00	1.00	0.96	0.78
	ΔT	28	28	26	23	28	28	26	23	28	28	26	23	27	28	27	23	26	26	26	23	24	24	24	21
kW	2.92	2.98	3.07	3.17	3.14	3.21	3.31	3.41	3.33	3.40	3.51	3.62	3.50	3.58	3.69	3.81	3.65	3.72	3.84	3.97	3.77	3.85	3.98	4.11	
Amps	13.8	14.1	14.4	14.8	14.7	14.9	15.3	15.8	15.7	16.0	16.4	16.9	16.5	16.9	17.3	17.9	17.4	17.7	18.2	18.8	18.2	18.6	19.1	19.8	
Hi-PR	235	253	268	279	264	284	300	313	300	323	341	356	342	368	389	406	385	414	437	456	425	458	483	504	
Lo-PR	113	120	131	140	119	127	139	148	124	132	144	154	130	139	152	161	137	145	159	169	141	150	164	175	
MBh	37.9	38.6	40.5	43.2	37.0	37.7	39.5	42.2	36.2	36.9	38.6	41.2	35.3	36.0	37.7	40.2	33.5	34.2	35.8	38.2	31.0	31.6	33.1	35.4	
S/T	0.93	0.90	0.81	0.66	0.96	0.93	0.84	0.68	0.99	0.95	0.86	0.70	1.00	0.98	0.89	0.72	1.00	1.00	0.92	0.75	1.00	1.00	0.93	0.75	
ΔT	28	28	26	23	29	28	27	23	29	28	27	23	29	29	27	23	27	28	27	23	25	26	25	22	
kW	2.86	2.91	3.00	3.10	3.07	3.13	3.23	3.33	3.25	3.32	3.43	3.54	3.42	3.49	3.60	3.72	3.56	3.63	3.75	3.87	3.68	3.76	3.88	4.01	
Amps	13.5	13.8	14.1	14.5	14.4	14.6	15.0	15.4	15.3	15.6	16.0	16.5	16.2	16.5	16.9	17.4	17.0	17.3	17.8	18.4	17.8	18.2	18.7	19.3	
Hi-PR	228	246	260	271	256	276	291	304	291	314	331	345	332	357	377	393	373	402	424	443	413	444	469	489	
Lo-PR	110	117	127	136	116	123	135	143	120	128	140	149	127	135	147	157	133	141	154	164	137	146	159	170	

Shaded area reflects ARI conditions
 High and low pressures are measured at the liquid and suction service valves.
 IDB: Entering Indoor Dry Bulb Temperature
 kW = Total system power
 Amps = outdoor unit amps (comp.+fan)

EXPANDED COOLING DATA — APG1560***41** — TWO STAGE

IDB	Airflow	Outdoor Ambient Temperature																							
		65°F				75°F				85°F				95°F				105°F				115°F			
		59	63	67	71	59	63	67	71	59	63	67	71	59	63	67	71	59	63	67	71	59	63	67	71
	MBh	55.4	57.4	62.9	-	54.1	56.1	61.4	-	52.8	54.7	59.9	-	51.5	53.4	58.5	-	48.9	50.7	55.6	-	45.3	47.0	51.5	-
	S/T	0.77	0.65	0.45	-	0.80	0.67	0.46	-	0.82	0.69	0.48	-	0.85	0.71	0.49	-	0.88	0.74	0.51	-	0.89	0.74	0.51	-
	ΔT	19	17	13	-	20	17	13	-	20	17	13	-	20	17	13	-	19	17	13	-	18	16	12	-
2036	kW	4.41	4.50	4.64	-	4.73	4.83	4.98	-	5.02	5.12	5.28	-	5.27	5.38	5.55	-	5.48	5.60	5.77	-	5.66	5.78	5.97	-
	Amps	21.5	21.8	22.4	-	22.7	23.1	23.7	-	24.2	24.6	25.3	-	25.4	25.9	26.6	-	26.7	27.2	27.9	-	28.0	28.5	29.3	-
	Hi PR	256	276	291	-	288	310	327	-	327	352	372	-	373	401	424	-	419	451	477	-	463	499	527	-
	Lo PR	107	114	124	-	113	120	131	-	118	125	137	-	124	131	144	-	130	138	150	-	134	143	156	-
	MBh	53.8	55.7	61.0	-	52.5	54.4	59.6	-	51.3	53.1	58.2	-	50.0	51.8	56.8	-	47.5	49.2	53.9	-	44.0	45.6	50.0	-
	S/T	0.74	0.62	0.43	-	0.76	0.64	0.44	-	0.78	0.65	0.45	-	0.81	0.68	0.47	-	0.84	0.70	0.49	-	0.85	0.71	0.49	-
	ΔT	20	17	13	-	20	18	13	-	20	18	13	-	21	18	14	-	20	18	13	-	19	16	12	-
70	kW	4.38	4.47	4.60	-	4.70	4.79	4.94	-	4.98	5.08	5.24	-	5.23	5.34	5.50	-	5.44	5.55	5.73	-	5.62	5.74	5.92	-
	Amps	21.3	21.7	22.2	-	22.6	23.0	23.5	-	24.0	24.5	25.1	-	25.3	25.7	26.4	-	26.5	27.0	27.7	-	27.8	28.3	29.1	-
	Hi PR	254	273	289	-	285	307	324	-	324	349	368	-	369	397	419	-	415	447	472	-	459	494	521	-
	Lo PR	106	113	123	-	112	119	130	-	116	124	135	-	122	130	142	-	128	136	149	-	133	141	154	-
	MBh	49.6	51.4	56.3	-	48.5	50.2	55.0	-	47.3	49.0	53.7	-	46.2	47.8	52.4	-	43.8	45.4	49.8	-	40.6	42.1	46.1	-
	S/T	0.71	0.59	0.41	-	0.74	0.62	0.43	-	0.76	0.63	0.44	-	0.78	0.65	0.45	-	0.81	0.68	0.47	-	0.82	0.68	0.47	-
	ΔT	20	18	13	-	21	18	14	-	21	18	14	-	21	18	14	-	21	18	14	-	19	17	13	-
1584	kW	4.28	4.37	4.50	-	4.59	4.68	4.82	-	4.86	4.96	5.11	-	5.10	5.21	5.37	-	5.31	5.42	5.59	-	5.48	5.60	5.78	-
	Amps	20.9	21.3	21.8	-	22.1	22.5	23.1	-	23.5	24.0	24.6	-	24.7	25.2	25.8	-	25.9	26.4	27.1	-	27.1	27.7	28.4	-
	Hi PR	246	265	280	-	276	297	314	-	314	338	357	-	358	385	407	-	403	433	458	-	445	479	506	-
	Lo PR	103	109	120	-	109	116	126	-	113	120	131	-	119	126	138	-	124	132	144	-	129	137	149	-

	MBh	56.3	58.0	62.7	67.3	55.0	56.6	61.3	65.8	53.7	55.3	59.8	64.2	52.4	53.9	58.4	62.6	49.8	51.2	55.5	59.5	46.1	47.5	51.4	55.1
	S/T	0.88	0.79	0.60	0.38	0.91	0.81	0.62	0.40	0.93	0.84	0.63	0.41	0.96	0.86	0.65	0.42	1.00	0.90	0.68	0.44	1.00	0.90	0.68	0.44
	ΔT	22	21	17	12	23	21	17	12	23	21	17	12	23	21	17	12	22	21	17	12	21	19	16	11
2036	kW	4.45	4.54	4.67	4.81	4.77	4.87	5.02	5.17	5.06	5.16	5.32	5.49	5.31	5.42	5.59	5.77	5.52	5.64	5.82	6.01	5.71	5.83	6.02	6.21
	Amps	21.6	22.0	22.5	23.1	22.9	23.3	23.9	24.5	24.4	24.8	25.4	26.2	25.6	26.1	26.8	27.6	26.9	27.4	28.2	29.0	28.2	28.7	29.5	30.4
	Hi PR	259	279	294	307	291	313	330	345	331	356	376	392	377	405	428	446	424	456	481	502	468	504	532	555
	Lo PR	108	115	126	134	114	122	133	141	119	126	138	147	125	133	145	154	131	139	152	162	135	144	157	167
	MBh	54.7	56.3	60.9	65.4	53.4	55.0	59.5	63.9	52.1	53.7	58.1	62.3	50.9	52.4	56.7	60.8	48.3	49.7	53.8	57.8	44.7	46.1	49.9	53.5
	S/T	0.84	0.75	0.57	0.37	0.87	0.78	0.59	0.38	0.89	0.80	0.60	0.39	0.92	0.82	0.62	0.40	0.95	0.85	0.65	0.42	0.96	0.86	0.65	0.42
	ΔT	23	21	18	12	24	22	18	12	24	22	18	12	24	22	18	12	23	22	18	12	22	20	17	11
1810	kW	4.41	4.50	4.64	4.78	4.73	4.83	4.98	5.13	5.02	5.12	5.28	5.45	5.27	5.38	5.55	5.72	5.48	5.60	5.77	5.96	5.66	5.78	5.97	6.16
	Amps	21.5	21.8	22.4	23.0	22.7	23.1	23.7	24.4	24.2	24.6	25.3	26.0	25.5	25.9	26.6	27.4	26.7	27.2	28.0	28.8	28.0	28.5	29.3	30.2
	Hi PR	257	276	292	304	288	310	327	341	327	352	372	388	373	401	424	442	419	451	477	497	463	499	527	549
	Lo PR	107	114	124	133	113	120	131	140	118	125	137	146	124	131	144	153	130	138	150	160	134	143	156	166
	MBh	50.5	51.9	56.2	60.3	49.3	50.7	54.9	58.9	48.1	49.5	53.6	57.5	46.9	48.3	52.3	56.1	44.6	45.9	49.7	53.3	41.3	42.5	46.0	49.4
	S/T	0.81	0.72	0.55	0.35	0.84	0.75	0.57	0.36	0.86	0.77	0.58	0.37	0.89	0.79	0.60	0.39	0.92	0.82	0.62	0.40	0.93	0.83	0.63	0.40
	ΔT	24	22	18	12	24	22	18	12	24	22	18	12	24	22	18	13	24	22	18	12	22	20	17	12
1584	kW	4.32	4.40	4.53	4.67	4.63	4.72	4.86	5.01	4.90	5.00	5.16	5.32	5.14	5.25	5.41	5.59	5.35	5.46	5.63	5.81	5.53	5.64	5.82	6.01
	Amps	21.0	21.4	21.9	22.5	22.3	22.7	23.2	23.9	23.7	24.1	24.7	25.4	24.9	25.4	26.0	26.8	26.1	26.6	27.3	28.2	27.3	27.9	28.6	29.5
	Hi PR	249	268	283	295	279	300	317	331	318	342	361	376	362	389	411	429	407	438	462	482	450	484	511	533
	Lo PR	104	111	121	129	110	117	128	136	114	121	133	141	120	128	139	148	126	134	146	155	130	138	151	161

Shaded area reflects ACCA (TVA) conditions IDB: Entering Indoor Dry Bulb Temperature kW = Total system power Amps = outdoor unit amps (comp.+fan)
 High and low pressures are measured at the liquid and suction service valves.

EXPANDED COOLING DATA — APG1560***41** — TWO STAGE (CONT.)

IDB	Airflow	Outdoor Ambient Temperature																							
		65°F				75°F				85°F				95°F				105°F				115°F			
		59	63	67	71	59	63	67	71	59	63	67	71	59	63	67	71	59	63	67	71	59	63	67	71
2036	MBh	57.3	58.6	62.6	66.9	56.0	57.2	61.1	65.3	54.6	55.8	59.6	63.8	53.3	54.5	58.2	62.2	50.6	51.7	55.3	59.1	46.9	47.9	51.2	54.7
	S/T	0.96	0.90	0.74	0.55	1.00	0.94	0.76	0.57	1.00	0.96	0.78	0.58	1.00	1.00	0.81	0.60	1.00	1.00	0.84	0.63	1.00	1.00	0.84	0.63
	ΔT	25	24	21	17	25	24	21	17	24	25	21	17	24	25	21	17	23	23	21	17	21	22	20	16
	kW	4.48	4.57	4.71	4.85	4.81	4.91	5.06	5.22	5.10	5.20	5.37	5.54	5.35	5.46	5.64	5.82	5.57	5.69	5.87	6.06	5.75	5.88	6.07	6.27
	Amps	21.7	22.1	22.7	23.3	23.0	23.5	24.0	24.7	24.5	25.0	25.6	26.4	25.8	26.3	27.0	27.8	27.1	27.6	28.4	29.2	28.4	28.9	29.7	30.6
	Hi PR	262	282	297	310	294	316	330	348	334	359	380	396	380	409	432	451	428	461	486	507	473	509	537	560
	Lo PR	109	116	127	135	116	123	134	143	120	128	139	148	126	134	146	156	132	141	153	163	137	145	159	169
	MBh	55.6	56.9	60.7	64.9	54.3	55.5	59.3	63.4	53.0	54.2	57.9	61.9	51.8	52.9	56.5	60.4	49.2	50.2	53.7	57.4	45.5	46.5	49.7	53.2
	S/T	0.92	0.86	0.70	0.52	0.95	0.89	0.73	0.54	0.98	0.92	0.75	0.56	1.00	0.95	0.77	0.58	1.00	0.98	0.80	0.60	1.00	0.99	0.81	0.60
	ΔT	26	25	22	17	26	25	22	18	26	25	22	18	26	25	22	18	25	25	22	17	23	23	20	16
kW	4.45	4.54	4.67	4.82	4.77	4.87	5.02	5.17	5.06	5.16	5.32	5.49	5.31	5.42	5.59	5.77	5.52	5.64	5.82	6.01	5.71	5.83	6.02	6.21	
Amps	21.6	22.0	22.5	23.1	22.9	23.3	23.9	24.5	24.4	24.8	25.4	26.2	25.6	26.1	26.8	27.6	26.9	27.4	28.2	29.0	28.2	28.7	29.5	30.4	
Hi PR	259	279	294	307	291	313	330	345	331	356	376	392	377	405	428	446	424	456	482	502	468	504	532	555	
Lo PR	108	115	126	134	114	122	133	141	119	126	138	147	125	133	145	154	131	139	152	162	135	144	157	167	
MBh	51.4	52.5	56.1	59.9	50.2	51.3	54.8	58.5	49.0	50.0	53.5	57.1	47.8	48.8	52.1	55.7	45.4	46.4	49.5	53.0	42.0	43.0	45.9	49.1	
S/T	0.89	0.83	0.68	0.51	0.92	0.86	0.70	0.52	0.94	0.88	0.72	0.54	0.97	0.91	0.74	0.55	1.01	0.95	0.77	0.58	1.02	0.95	0.78	0.58	
ΔT	26	25	22	18	27	26	22	18	27	26	22	18	27	26	22	18	27	25	22	18	25	24	21	17	
kW	4.35	4.43	4.57	4.70	4.66	4.76	4.90	5.05	4.94	5.04	5.20	5.36	5.18	5.29	5.46	5.63	5.39	5.51	5.68	5.86	5.57	5.69	5.87	6.06	
Amps	21.2	21.5	22.1	22.7	22.4	22.8	23.4	24.0	23.9	24.3	24.9	25.6	25.1	25.6	26.2	27.0	26.3	26.8	27.5	28.4	27.5	28.1	28.8	29.7	
Hi PR	251	270	286	298	282	304	321	334	321	345	365	380	365	393	415	433	411	442	467	487	454	489	516	538	
Lo PR	105	112	122	130	111	118	129	137	115	123	134	143	121	129	141	150	127	135	147	157	131	140	152	162	

2036	MBh	58.3	59.4	62.2	66.4	56.9	58.1	60.8	64.9	55.6	56.7	59.4	63.3	54.2	55.3	57.9	61.8	51.5	52.5	55.0	58.7	47.7	48.7	51.0	54.4
	S/T	1.00	0.98	0.88	0.71	1.00	1.00	0.91	0.74	1.00	1.00	0.94	0.76	1.00	1.00	0.97	0.78	1.00	1.00	1.00	0.81	1.00	1.00	1.00	0.82
	ΔT	26	26	25	21	26	26	25	22	25	26	25	22	24	25	25	22	23	24	25	22	22	22	23	20
	kW	4.52	4.61	4.74	4.89	4.85	4.94	5.10	5.26	5.14	5.24	5.41	5.58	5.39	5.51	5.68	5.87	5.61	5.73	5.92	6.11	5.80	5.93	6.12	6.32
	Amps	21.9	22.3	22.8	23.4	23.2	23.6	24.2	24.9	24.7	25.2	25.8	26.6	26.0	26.5	27.2	28.0	27.3	27.8	28.6	29.4	28.6	29.2	29.9	30.9
	Hi PR	264	284	300	313	297	319	337	352	337	363	383	400	384	413	437	455	432	465	491	512	478	514	543	566
	Lo PR	110	117	128	137	117	124	135	144	121	129	141	150	127	135	148	158	133	142	155	165	138	147	160	171
	MBh	56.6	57.7	60.4	64.5	55.3	56.4	59.0	63.0	54.0	55.0	57.6	61.5	52.7	53.7	56.2	60.0	50.0	51.0	53.4	57.0	46.3	47.2	49.5	52.8
	S/T	0.96	0.93	0.84	0.68	1.00	0.96	0.87	0.71	1.00	0.99	0.89	0.72	1.00	1.00	0.92	0.75	1.00	1.00	0.96	0.78	1.00	1.00	0.96	0.78
	ΔT	28	27	26	22	28	28	26	23	27	28	26	23	27	27	26	23	25	26	26	22	24	24	24	21
kW	4.48	4.57	4.71	4.85	4.81	4.91	5.06	5.22	5.10	5.20	5.37	5.54	5.35	5.46	5.64	5.82	5.57	5.69	5.87	6.06	5.75	5.88	6.07	6.27	
Amps	21.7	22.1	22.7	23.3	23.0	23.5	24.0	24.7	24.5	25.0	25.6	26.4	25.8	26.3	27.0	27.8	27.1	27.6	28.4	29.2	28.4	28.9	29.7	30.6	
Hi PR	262	282	297	310	294	316	334	348	334	359	380	396	380	409	432	451	428	461	486	507	473	509	537	560	
Lo PR	109	116	127	135	116	123	134	143	120	128	139	148	126	134	146	156	132	141	153	163	137	145	159	169	
MBh	52.2	53.3	55.8	59.5	51.0	52.0	54.5	58.1	49.8	50.8	53.2	56.7	48.6	49.5	51.9	55.4	46.2	47.1	49.3	52.6	42.8	43.6	45.7	48.7	
S/T	0.93	0.90	0.81	0.66	0.96	0.93	0.84	0.68	0.99	0.95	0.86	0.70	1.00	0.98	0.89	0.72	1.00	1.00	0.92	0.75	1.00	1.00	0.93	0.75	
ΔT	28	28	26	23	29	28	27	23	29	28	27	23	28	28	27	23	27	27	26	23	25	25	25	21	
kW	4.38	4.47	4.60	4.74	4.70	4.79	4.94	5.09	4.98	5.08	5.24	5.40	5.22	5.33	5.50	5.68	5.43	5.55	5.73	5.91	5.62	5.74	5.92	6.11	
Amps	21.3	21.7	22.2	22.8	22.6	23.0	23.5	24.2	24.0	24.5	25.1	25.8	25.3	25.7	26.4	27.2	26.5	27.0	27.7	28.6	27.7	28.3	29.0	29.9	
Hi PR	254	273	288	301	285	307	324	338	324	349	368	384	369	397	419	437	415	447	472	492	459	494	521	544	
Lo PR	106	113	123	131	112	119	130	139	116	124	135	144	122	130	142	151	128	136	149	159	133	141	154	164	

Shaded area reflects ARI conditions IDB: Entering Indoor Dry Bulb Temperature kW = Total system power Amps = outdoor unit amps (comp.+fan)
 High and low pressures are measured at the liquid and suction service valves.

PRODUCT SPECIFICATIONS

DIMENSIONS

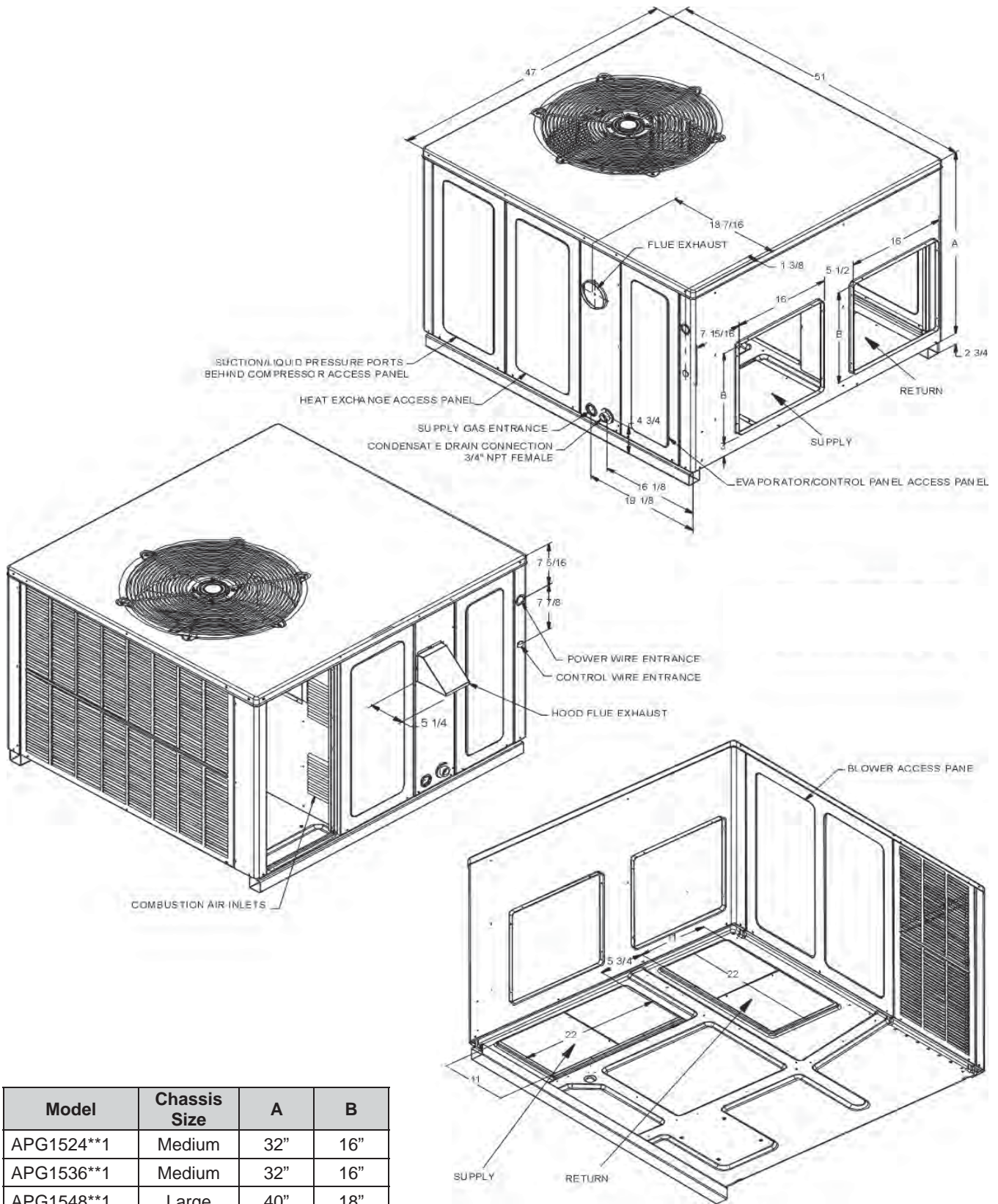

Model	Chassis Size	A	B
APG1524**1	Medium	32"	16"
APG1536**1	Medium	32"	16"
APG1548**1	Large	40"	18"
APG1560**1	Large	40"	18"

PRODUCT SPECIFICATIONS

WIRING DIAGRAMS (CONT.)

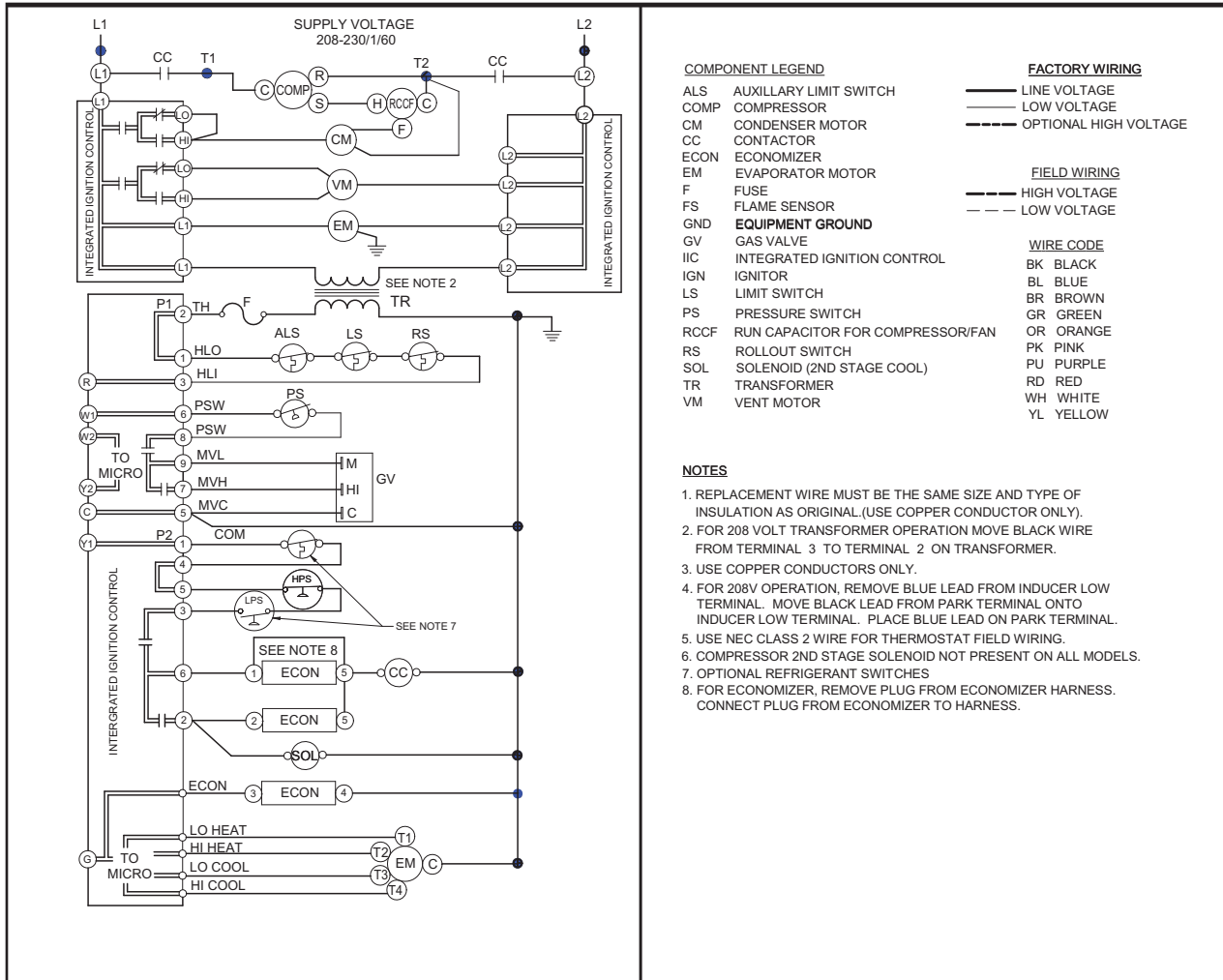

DIAGNOSTIC LED - RED	STATUS	CHECK
ON	NORMAL OPERATION	-
OFF	NO POWER OR INTERNAL CONTROL FAULT	CHECK INPUT POWER CHECK FUSE(S) REPLACE CONTROL
1 FLASH	IGNITION FAILURE	GAS FLOW GAS PRESSURE GAS VALVE FLAME SENSOR
2 FLASHES	PRESSURE SWITCH OPEN	CHECK PRESSURE SWITCH CHECK TUBING CHECK VENT MOTOR
3 FLASHES	PRESSURE SWITCH CLOSED WITHOUT INDUCER ON	CHECK PRESSURE SWITCH CHECK WIRING FOR SHORTS
4 FLASHES	OPEN LIMIT SWITCH	CHECK MAIN LIMIT SWITCH CHECK AUXILIARY LIMIT SW. CHECK ROLLOUT LIMIT SW.
5 FLASHES	FALSE FLAME DETECTED	CHECK GAS VALVE CHECK FOR SHORTS IN FLAME SENSOR WIRING
6 FLASHES	COMPR. SHORT CYCLE DELAY	3 MIN COMP. SHORT CYCLE DELAY

DIAGNOSTIC LED - RED	STATUS	CHECK
7 FLASHES	LIMIT OPEN 5 TIMES IN SAME CALL FOR HEAT	CHECK MAIN LIMIT SWITCH CHECK AUXILIARY LIMIT SW.
8 FLASHES	IDT/ODT OPEN	CHECK JUMPER BETWEEN 1 AND 4 ON 6-CIRCUIT CONNECTOR CHECK OPTIONAL REFRIGERANT SWITCHES
9 FLASHES	PSW/LOC OPEN	CHECK REFRIGERANT SWITCHES FOR LOSS OF CHARGE OR HIGH HEAD PRESSURE

DIAGNOSTIC LED - AMBER	STATUS	CHECK
OFF	NO FLAME PRESENT	-
ON	NORMAL FLAME PRESENT	-
1 FLASH	LOW FLAME SIGNAL	GAS FLOW GAS PRESSURE GAS VALVE FLAME SENSOR
2 FLASHES	FALSE FLAME DETECTED	CHECK GAS VALVE CHECK FOR SHORTS IN FLAME SENSOR WIRING

0140G00533 REV A

Wiring is subject to change. Always refer to the wiring diagram on the unit for the most up-to-date wiring.

	WARNING	High Voltage: Disconnect all power before servicing or installing this unit. Multiple power sources may be present. Failure to do so may cause property damage, personal injury, or death.	
--	----------------	--	--

ACCESSORIES

Description	Part Numbers		
	Small Chassis	Medium Chassis	Large Chassis
Roof Curb	PGC101/102/103	PGC101/102/103	PGC101/102/103
Downflow Economizer	PGED101/102	PGED101/102	PGED103
Horizontal Economizer	PGEH101/102	PGEH101/102	PGEH103
Downflow Manual Damper	PGMDD101/102	PGMDD101/102	PGMDD103
Downflow Motorized Damper	PGMDMD 101/102	PGMDMD 101/102	PGMDMD 103
Horizontal Manual Damper	PGMDH101	PGMDH102	PGMDH103
Horizontal Motorized Damper	PGMDMH 101	PGMDMH 102	PGMDMH 103
Filter Rack	PGFR101/102/103	PGFR101/102/103	PGFR101/102/103
Downflow Square-to-Round	SQRPG101/102	SQRPG101/102	SQRPG103
Horizontal Square-to-Round	SQRPGH101/102	SQRPGH101/102	SQRPGH103
Concentric Converter	CDK1-2	CDK1-2	CDK3
The above accessories are offered by McDaniel Metals • Main: (281) 987-8400 • Fax: (281) 987-9494			
LPM-05	L.P. Conversion Kit		

THERMOSTATS

Part Number	Description
CHSATG	White, 1-Stage Heating/1-Stage Cooling, Non-programmable
CH70TG	White, 1-Stage Heating/1-Stage Cooling, Non-programmable, Digital
CHTS36-60	Beige, 1-Stage Heating/2-Stage Cooling
1213423	White, 2-Stage Heating/2-Stage Cooling, Digital

NOTES

