



Air Conditioning & Heating

PRODUCT SPECIFICATIONS



11.5 EER / 80% AFUE

THREE-PHASE

COOLING CAPACITY: 90,000 — 118,000 BTU/h

HEATING CAPACITY: 168,000 BTU/h



CPG COMMERCIAL

7½- TO 10-TON SELF-CONTAINED PACKAGED GAS/ELECTRIC UNITS

The new Goodman® CPG Commercial Packaged Gas/Electric Units feature the environmentally friendly refrigerant R-410A, which is chlorine-free to help prevent damage to the ozone layer. Other features include our patented TuffTube™ dual-diameter tubular heat exchanger and a high-efficiency scroll compressor. These units are housed in a heavy-gauge, galvanized-steel cabinet with UV-resistant power-paint finish.

Standard Features

- Environmentally friendly R-410A refrigerant
- TuffTube™ tubular heat exchanger
- High-efficiency scroll compressor
- Copper tube / aluminum fin coils
- Contactor with lugs
- High-capacity, steel-cased filter dryer
- Single-point entry
- 24-volt terminal strip
- Convertible
- Easy to service
- Built-in filter rack with standard 2" filters
- Bottom utility entry
- Complies with California NOx emissions standards
- ARI Certified; ETL Listed

Cabinet Features

- Heavy-gauge, galvanized-steel cabinet with UV-resistant powder-paint finish
- Full Perimeter Rail
- Curb Fit

Contents

Nomenclature.....	2
Product Specifications.....	3
Airflow Data	5
Cooling Data Summary	7
Expanded Cooling Data.....	8
Dimensions.....	12
Wiring Diagram	16
Accessories	20



NOMENCLATURE

	C	P	G	060	070	1	D	X	X	X	
	1	2	3	4,5,6	7,8,9	10	11	12	13	14	
Brand	C Commercial										Factory-Installed Options (Coming Soon)
Configuration	P Packaged Multi-Position										Special Features X No Features
Application	C Cooling G Gas Heat H Heat Pump										Special Treatment X No Treatment/ Standard Aluminized Heat Exchanger (AH)
Nominal Gross Cooling Capacity	036 3 Tons 048 4 Tons 060 5 Tons 072 6 Tons 090 7½ Tons 102 8½ Tons	120 10 Tons 150 12½ tons 180 15 Tons 240 20 Tons 300 25 Tons									Economizer Options (Factory Installed) X No Economizer
Heating Capacity	CPG 070 70,000 BTU/h 105 105,000 BTU/h 140 140,000 BTU/h 210 210,000 BTU/h 350 350,000 BTU/h 400 400,000 BTU/h	CPC/CPH XXX No Heat 010 10 kW Electric Heater 015 15 kW Electric Heater 020 20 kW Electric Heater 025 25 kW Electric Heater									Supply Fan/Drive Type/Motor B Belt Drive D Direct Drive H High-Static Belt Drive
											Voltage 1 208v 1 Phase 2 220/240V 1 Phase 5 3 208v 3 Phase 4 460v 3 Phase 5 380/415v 3 Phase 50 Hz 7 575v 3 Phase

PRODUCT SPECIFICATIONS — 7½ TONS

	CPG0902103B***	CPG0902104B***	CPG0902107B***
Cooling Capacity			
Total BTU/h	90,000	90,000	90,000
Sensible BTU/h	65,700	65,700	65,700
EER / IPLV	11.5 / 12.3	11.5 / 12.3	11.5 / 12.3
Decibels	82.0	82.0	82.0
ARI Reference #s	3000985	3000985	3000985
Heating Capacity			
Max. Input BTU/h	210,000	210,000	210,000
Output BTU/h	168,000	168,000	168,000
Steady-State Efficiency (AFUE)	80	80	80
Temperature Rise Range (°F)	35	35	35
No. of Burners	6	6	6
Evaporator Motor / Coil			
Motor Type	Belt Drive	Belt Drive	Belt Drive
Indoor Nominal CFM	3,000	3,000	3,000
Motor Speed Tap / FLA (Cooling)	-- / 5.0	-- / 2.5	-- / 2.3
Horsepower / RPM	1½ / 1725	1½ / 1725	1½ / 1725
Piston Size (Cooling)	0.076	0.076	0.076
Filter Size	16" x 24" x 2"	16" x 24" x 2"	16" x 24" x 2"
Drain Size (NPT)	¾"	¾"	¾"
R-410A Refrigerant Charge: Cir #1 / #2 (oz.)	215 / 215	215 / 215	215 / 215
Evaporator Coil Face Area (ft²)	10.2	10.2	10.2
Rows Deep / Fins per Inch	4 / 16	4 / 16	4 / 16
Belt Drive Evap Fan Data			
# of Wheels (D x W)	1 (15" x 12")	1 (15" x 12")	1 (15" x 12")
Motor / Blower Sheave	VL40 / AK74	VL40 / AK74	VL40 / AK74
Belt	AX51	AX51	AX51
Rows Deep / Fins per Inch	4 / 16	4 / 16	4 / 16
Condenser Fan / Coil			
Quantity of condenser Fan Motors	2	2	2
Horsepower - RPM	¼ - 1090	¼ - 890	¼ - 1075
Fan Diameter / # Fan Blades	22 / 4	22 / 4	22 / 4
Outdoor Nominal CFM	76,00	76,00	76,00
Face Area (ft²)	32.4	32.4	32.4
Rows Deep / Fins per Inch	2 / 20	2 / 20	2 / 20
Electrical Data			
Voltage / Phase / Frequency	208-230 / 3 / 60	460 / 3 / 60	575 / 3 / 60
Quantity of Compressors	2	2	2
Compressor RLA / LRA	13.1 / 83.1	6.1 / 41.0	4.4 / 33.0
Outdoor Fan HP / RLA	¼ / 1.4	¼ / 0.8	¼ / 0.6
Total Unit Amps	34.1	16.3	12.2
Min. Circuit Ampacity ¹	37	18	13
Max. Overcurrent Protection (amps) ²	50	20	15
Entrance Power Supply & Control Voltage	Locating Dimple	Locating Dimple	Locating Dimple
Operating Weight (lbs)	1210	1210	1210
Ship Weight (lbs)	1250	1250	1250

¹ Wire size should be determined in accordance with National Electrical Codes. Extensive wire runs will require larger wire sizes.

² May use fuses or HACR-type circuit breakers of the same size as noted.

Note: Always check the S&R plate for electrical data on the unit being installed.

PRODUCT SPECIFICATIONS — 10 TONS

	CPG120***3B***	CPG120***4B***	CPG120***7B***
Cooling Capacity			
Total BTU/h	118,000	118,000	118,000
Sensible BTU/h	87,300	87,300	87,300
EER / IPLV	11.50 / 12.00	11.50 / 12.00	11.50 / 12.00
Decibels	83.0	83.0	83.0
ARI Reference #s	3023834	3023834	3023834
Heating Capacity			
Max. Input BTU/h	210,000	210,000	210,000
Output BTU/h	168,000	168,000	168,000
Steady State Efficiency	80	80	80
Temperature Rise Range (°F)	25-55	25-55	25-55
No. of Burners	6	6	6
Evaporator Motor / Coil			
Motor Type	Belt Drive	Belt Drive	Belt Drive
Indoor Nominal CFM	4,000	4,000	4,000
Indoor motor FLA (Cooling)	7.8	3.9	2.7
Horsepower - RPM	2.0 - 1,725	2.0 - 1,725	2.0 - 1,725
Piston Size (Cooling)	0.086	0.086	0.086
Filter Size	(4) 16" x 24" x 2"	(4) 16" x 24" x 2"	(4) 16" x 24" x 2"
Drain Size (NPT)	¾"	¾"	¾"
R-410A Refrigerant Charge Cir #1(oz.)	220	220	220
R-410A Refrigerant Charge Cir #2(oz.)	220	220	220
Evaporator Coil Face Area (ft²)	10.2	10.2	10.2
Rows Deep / Fins per Inch	4 / 16	4 / 16	4 / 16
Belt Drive Evap Fan Data			
# of Wheels (D x W)	(1) 15" x 15"	(1) 15" x 15"	(1) 15" x 15"
Motor Sheave / Blower Sheave	VL40 / AK74	VL40 / AK74	VL40 / AK74
Belt	AX51	AX51	AX51
Rows Deep / Fins per Inch	4 / 14	4 / 14	4 / 14
Condenser Fan / Coil			
Quantity of condenser Fan Motors	2	2	2
Horsepower - RPM	⅓ - 1,075	⅓ - 1,075	⅓ - 1,075
Fan Motor Amps (Cooling) ea.	2.40	1.20	0.84
Fan Diameter / # Fan Blades	22 / 3	22 / 3	22 / 3
Outdoor Nominal CFM	7,200	7,200	7,200
Face Area (ft²)	32.4	32.4	32.4
Rows Deep/ Fins per Inch	2/2 rows 22 fpi	2/2 rows 22 fpi	2/2 rows 22 fpi
Electrical Data			
Voltage/Phase/ Frequency	208-230/3/60	460/3/60	575/3/60
Quantity of Compressors	2	2	2
Compressor RLA / LRA ea.	16 / 110.0	7.8 / 52.0	5.7 / 38.9
Standard Max Static	2.0"	2.0"	2.0"
Outdoor Fan RLA ea.	2.40	1.20	0.89
Total Unit Amps	45	22	16
Min. Circuit Ampacity ¹	49	24	17
Max. Overcurrent Protection (amps) ²	60	30	20
Entrance Power Supply	Locating Dimple	Locating Dimple	Locating Dimple
Entrance Control Voltage	Locating Dimple	Locating Dimple	Locating Dimple
Operating Weight (lbs)	1235	1235	1235
Ship Weight (lbs)	1275	1275	1275

¹ Wire size should be determined in accordance with National Electrical Codes. Extensive wire runs will require larger wire sizes.

² May use fuses or HACR-type circuit breakers of the same size as noted.

Note: Always check the S&R plate for electrical data on the unit being installed.

AIRFLOW DATA — 7½ TONS

Standard Belt Drive — Down Shot

ESP, In H ₂ O	Turns Open																	
	0			1			2			3			4			5		
	CFM	RPM	BHP	CFM	RPM	BHP	CFM	RPM	BHP	CFM	RPM	BHP	CFM	RPM	BHP	CFM	RPM	BHP
0.1										3522	750	1.14	3228	706	0.94	2964	661	0.73
0.3							3337	800	1.19	3102	756	1	2800	706	0.76	2504	661	0.59
0.5				3387	844	1.32	2834	806	0.99	2603	757	0.8						
0.7	3453	893	1.5	2903	850	1.12												
0.9	2957	899	1.29															

High-Static Belt Drive — Down Shot

ESP, In H ₂ O	Turns Open																	
	0			1			2			3			4			5		
	CFM	RPM	BHP	CFM	RPM	BHP	CFM	RPM	BHP	CFM	RPM	BHP	CFM	RPM	BHP	CFM	RPM	BHP
0.7																3575	904	1.66
0.9													3258	925	1.56	3113	909	1.41
1.1										3580	1013	1.97	3001	948	1.42	2722	915	1.25
1.3							3616	1063	2.17	3247	1019	1.79	2646	959	1.3			
1.5							3275	1069	2.05	2803	1025	1.68						
1.7				3346	1118	2.24	2885	1074	1.97									
1.9				3009	1125	2.05												
2.1																		

Standard Belt Drive — Horizontal

ESP, In H ₂ O	Turns Open																	
	0			1			2			3			4			5		
	CFM	RPM	BHP	CFM	RPM	BHP	CFM	RPM	BHP	CFM	RPM	BHP	CFM	RPM	BHP	CFM	RPM	BHP
0.1													3381	703	0.99	3078	659	0.78
0.3							3560	796	1.26	3271	747	1.02	2946	703	0.82	2604	659	0.63
0.5				3492	841	1.36	3159	799	1.09	2819	752	0.86						
0.7	3453	891	1.5	3094	846	1.18												
0.9	2964	896	1.29	2524	852	0.96												
1.1	2537	902	1.08															

High-Static Belt Drive — Horizontal

ESP, In H ₂ O	Turns Open																	
	0			1			2			3			4			5		
	CFM	RPM	BHP	CFM	RPM	BHP	CFM	RPM	BHP	CFM	RPM	BHP	CFM	RPM	BHP	CFM	RPM	BHP
0.7																3567	903	1.58
0.9													3596	953	1.79	3145	906	1.39
1.1										3630	1007	1.97	3168	963	1.56	2675	909	1.18
1.3							3649	1063	2.19	3255	1021	1.8	2724	965	1.35			
1.5							3316	1068	2.0	2823	1058	1.61						
1.7				3287	1112	2.16	2869	1074	1.78									
1.9				2970	1122	2.0												
2.1				2644	1133	1.92												

Notes :

Assume dry coil with filter in place; CFM correction for wet coil = 3%

Any adjustment made to the blower should not cause the motor to draw more than the motor rated RLA. Applications that exceed the above could require a larger motor. Minimum rated SCFM is 350 per ton.

AIRFLOW DATA — 10 TONS

Standard Belt-Drive Down-shot

ESP, In H ₂ O	Turns Open																	
	0			1			2			3			4			5		
	CFM	RPM	BHP	CFM	RPM	BHP	CFM	RPM	BHP	CFM	RPM	BHP	CFM	RPM	BHP	CFM	RPM	BHP
0.2							4316	780	1.57	4118	738	1.36	3771	687	1.08	3376	644	0.85
0.4				4282	830	1.76	3928	786	1.4	3595	740	1.13						
0.6	4232	874	1.87	3872	830	1.52	3444	786	1.2									
0.8	3839	880	1.64	3367	836	1.27												
1	3326	885	1.4															
1.2																		
1.4																		

High-Static Belt-Drive Down-shot

ESP, In H ₂ O	Turns Open																	
	0			1			2			3			4			5		
	CFM	RPM	BHP	CFM	RPM	BHP	CFM	RPM	BHP	CFM	RPM	BHP	CFM	RPM	BHP	CFM	RPM	BHP
0.8													4188	943	2.11	3793	889	1.67
1										4305	1002	2.39	3836	946	1.89	3416	893	1.45
1.2							4324	1053	2.63	3879	1003	2.11	3425	951	1.63			
1.4				4428	1109	2.92	3973	1056	2.35	3434	1009	1.8						
1.6	4465	1160	3.2	4088	1113	2.67	3506	1068	2.1									
1.8	4129	1168	2.9	3625	1122	2.3												
2	3694	1175	2.65															

Standard Belt-Drive Horizontal

ESP, In H ₂ O	Turns Open																	
	0			1			2			3			4			5		
	CFM	RPM	BHP	CFM	RPM	BHP	CFM	RPM	BHP	CFM	RPM	BHP	CFM	RPM	BHP	CFM	RPM	BHP
0.2										4391	737	1.48	4054	693	1.22	3760	645	0.97
0.4							4314	781	1.61	3969	737	1.29	3534	693	1			
0.6				4255	826	1.69	3894	781	1.38	3447	743	1.09						
0.8	4234	876	1.85	3792	832	1.47												
1	3724	877	1.59															
1.2																		
1.4																		

High-Static Belt-Drive Horizontal

ESP, In H ₂ O	Turns Open																				
	0			1			2			3			4			5					
	CFM	RPM	BHP	CFM	RPM	BHP	CFM	RPM	BHP	CFM	RPM	BHP	CFM	RPM	BHP	CFM	RPM	BHP			
0.8	DO NOT OPERATE															4408	885	2.02			
1													4464	940	2.29	3929	891	1.76			
1.2													4585	996	2.58	4026	946	2	3436	897	1.46
1.4										4697	1049	2.92	4141	1001	2.26	3509	951	1.7			
1.6										4264	1056	2.58	3663	1007	1.96						
1.8							4359	1105	2.85	3785	1061	2.22									
2							3907	1114	2.49												

COOLING DATA SUMMARY

10 Tons

Indoor Air		Condenser Air Temperature														
		75			85			95			105			115		
SCFM	WB	Total MBTU/h	Sens MBTU/h	Watts KWH	Total MBTU/h	Sens MBTU/h	Watts KWH	Total MBTU/h	Sens MBTU/h	Watts KWH	Total MBTU/h	Sens MBTU/h	Watts KWH	Total MBTU/h	Sens MBTU/h	Watts KWH
2400	71	94.8	47.1	7.13	92.5	47.2	7.56	90.3	47.5	7.93	85.8	46.8	8.25	79.4	43.7	8.53
	67	88.7	59.0	6.92	86.6	59.0	7.33	84.5	59.4	7.69	80.2	58.6	8.00	74.3	54.8	8.27
	63	83.0	67.8	6.72	81.0	67.9	7.12	79.0	68.4	7.46	75.1	67.4	7.76	69.6	63.0	8.02
	59	81.2	70.8	6.59	79.3	70.8	6.97	77.4	71.3	7.31	73.5	70.3	7.60	68.1	65.7	7.85
3000	71	102.7	52.9	7.30	100.3	53.0	7.74	97.8	53.4	8.13	92.9	52.6	8.46	86.1	49.2	8.74
	67	96.1	66.3	7.08	93.8	66.3	7.51	91.5	66.8	7.88	86.9	65.9	8.20	80.5	61.5	8.47
	63	89.9	76.2	6.88	87.8	76.3	7.29	85.6	76.8	7.64	81.4	75.7	7.95	75.4	70.7	8.21
	59	88.0	79.5	6.74	85.9	79.6	7.14	83.8	80.2	7.49	79.6	79.0	7.79	73.8	73.8	8.04
3375	71	105.8	57.2	7.36	103.3	57.2	7.80	100.7	57.6	8.19	95.7	56.8	8.53	88.7	53.1	8.81
	67	99.0	71.6	7.14	96.6	71.6	7.57	94.2	72.1	7.94	89.5	71.1	8.26	82.9	66.4	8.54
	63	92.6	82.3	6.93	90.4	82.4	7.34	88.2	83.0	7.70	83.8	83.8	8.01	77.6	77.6	8.28
	59	90.6	85.9	6.79	88.5	88.5	7.19	86.3	86.3	7.55	82.0	82.0	7.85	76.0	76.0	8.11

Sensible heat capacities shown are based on 80°F DB entering air at the evaporator coil.

For sensible heat capacities at other than 80°F DB, deduct 84 BTU/h per 100 CFM of evaporator coil air for each degree below 80°F, or add 84 BTU/h per 100 CFM of evaporator coil air per degree above 80°F.

Capacities at 95°F Outdoor, 75°F DB and 63°F WB Indoor

Total MBTU/h **84.8** Sensible MBTU/h **66.1** Latent MBTU/h **18.7**

10 Tons

Indoor Air		Condenser Air Temperature														
		75			85			95			105			115		
SCFM	WB	Total MBTU/h	Sens MBTU/h	Watts KWH	Total MBTU/h	Sens MBTU/h	Watts KWH	Total MBTU/h	Sens MBTU/h	Watts KWH	Total MBTU/h	Sens MBTU/h	Watts KWH	Total MBTU/h	Sens MBTU/h	Watts KWH
3200	71	122.3	61.6	9.75	119.3	61.7	10.32	116.4	62.1	10.82	110.6	61.2	11.25	102.5	57.2	11.62
	67	114.4	77.1	9.47	111.6	77.2	10.02	108.9	77.7	10.50	103.5	76.6	10.91	95.8	71.6	11.27
	63	107.0	88.7	9.20	104.5	88.7	9.73	101.9	89.4	10.20	96.8	88.1	10.59	89.7	82.3	10.93
	59	104.8	92.5	9.03	102.3	92.6	9.54	99.8	93.3	9.99	94.8	92.0	10.38	87.8	85.9	10.71
4000	71	132.4	69.2	9.98	129.3	69.3	10.56	126.1	69.8	11.08	119.8	68.8	11.52	111.0	64.3	11.90
	67	123.9	86.6	9.69	121.0	86.7	10.25	118.0	87.3	10.75	112.1	86.1	11.17	103.8	80.4	11.54
	63	116.0	99.6	9.41	113.2	99.7	9.96	110.4	100.4	10.43	104.9	99.0	10.84	97.2	92.5	11.19
	59	113.5	103.9	9.23	110.8	104.1	9.76	108.1	104.8	10.23	102.7	102.7	10.62	95.1	95.1	10.97
4500	71	136.4	74.7	10.05	133.2	74.8	10.65	129.9	75.4	11.17	123.4	74.3	11.61	114.3	69.4	12.00
	67	127.6	93.6	9.76	124.6	93.6	10.33	121.5	94.3	10.83	115.5	93.0	11.26	107.0	86.9	11.63
	63	119.4	107.6	9.48	116.6	107.7	10.03	113.8	108.5	10.51	108.1	108.1	10.93	100.1	100.1	11.28
	59	116.9	112.3	9.30	114.1	114.1	9.83	111.3	111.3	10.30	105.8	105.8	10.71	98.0	98.0	11.05

Sensible heat capacities shown are based on 80°F DB entering air at the evaporator coil.

For sensible heat capacities at other than 80°F DB, deduct 84 BTU/h per 100 CFM of evaporator coil air for each degree below 80°F, or add 84 BTU/h per 100 CFM of evaporator coil air per degree above 80°F.

Capacities at 95°F Outdoor, 75°F DB and 63°F WB Indoor

Total MBTU/h **109.3** Sensible MBTU/h **86.4** Latent MBTU/h **22.9**

EXPANDED COOLING DATA — 7½ TONS

IDB*	Airflow	Outdoor Ambient Temperature																							
		65				75				85				95				105				115			
		59	63	67	71	59	63	67	71	59	63	67	71	59	63	67	71	59	63	67	71	59	63	67	71
70	MBh	88.2	91.4	100.2	-	86.1	89.3	97.8	-	84.1	87.2	95.5	-	82.0	85.0	93.2	-	77.9	80.8	88.5	-	72.2	74.8	82.0	-
	S/T	0.73	0.61	0.42	-	0.76	0.63	0.44	-	0.78	0.65	0.45	-	0.80	0.67	0.47	-	0.83	0.70	0.48	-	0.84	0.70	0.49	-
	ΔT	18	15	12	-	18	15	12	-	18	15	12	-	18	16	12	-	18	15	12	-	17	14	11	-
	kW	6.19	6.32	6.50	-	6.64	6.77	6.98	-	7.03	7.17	7.39	-	7.37	7.53	7.76	-	7.67	7.83	8.08	-	7.92	8.09	8.35	-
	Amps	20.4	20.8	21.2	-	21.6	22.0	22.5	-	23.0	23.4	24.0	-	24.1	24.6	25.2	-	25.3	25.8	26.5	-	26.5	27.0	27.7	-
	Hi pr	234	252	266	-	262	282	298	-	298	321	339	-	340	366	386	-	382	411	434	-	422	454	480	-
	Lo Pr	108	115	126	-	114	122	133	-	119	126	138	-	125	133	145	-	131	139	152	-	135	144	157	-
	MBh	85.6	88.7	97.2	-	83.6	86.7	95.0	-	81.6	84.6	92.7	-	79.7	82.6	90.5	-	75.7	78.4	85.9	-	70.1	72.6	79.6	-
	S/T	0.70	0.58	0.40	-	0.72	0.61	0.42	-	0.74	0.62	0.43	-	0.77	0.64	0.44	-	0.80	0.66	0.46	-	0.80	0.67	0.46	-
	ΔT	18	16	12	-	19	16	12	-	19	16	12	-	19	16	12	-	18	16	12	-	17	15	11	-
	kW	6.15	6.27	6.45	-	6.59	6.72	6.92	-	6.98	7.12	7.34	-	7.32	7.47	7.70	-	7.61	7.77	8.01	-	7.86	8.03	8.28	-
	Amps	20.3	20.6	21.1	-	21.4	21.8	22.4	-	22.8	23.2	23.8	-	24.0	24.4	25.0	-	25.1	25.6	26.3	-	26.3	26.8	27.5	-
Hi pr	231	249	263	-	260	279	295	-	295	318	336	-	336	362	382	-	378	407	430	-	418	450	475	-	
Lo Pr	107	114	124	-	113	120	132	-	118	125	137	-	124	132	144	-	130	138	150	-	134	143	156	-	
MBh	79.0	81.9	89.7	-	77.2	80.0	87.7	-	75.4	78.1	85.6	-	73.5	76.2	83.5	-	69.8	72.4	79.3	-	64.7	67.1	73.5	-	
S/T	0.67	0.56	0.39	-	0.70	0.58	0.40	-	0.72	0.60	0.41	-	0.74	0.62	0.43	-	0.77	0.64	0.44	-	0.77	0.65	0.45	-	
ΔT	20	18	13	-	21	18	14	-	21	18	14	-	21	18	14	-	21	18	13	-	19	17	13	-	
kW	6.01	6.13	6.31	-	6.44	6.57	6.76	-	6.81	6.95	7.16	-	7.15	7.29	7.52	-	7.43	7.58	7.82	-	7.67	7.83	8.08	-	
Amps	19.9	20.2	20.7	-	21.0	21.4	21.9	-	22.3	22.7	23.3	-	23.5	23.9	24.5	-	24.6	25.1	25.7	-	25.7	26.2	26.9	-	
Hi pr	224	242	255	-	252	271	286	-	286	308	326	-	326	351	371	-	367	395	417	-	406	436	461	-	
Lo Pr	104	111	121	-	110	117	128	-	114	121	133	-	120	128	139	-	126	134	146	-	130	138	151	-	
75	MBh	89.7	92.3	100.0	107.3	87.6	90.2	97.6	104.8	85.5	88.0	95.3	102.3	83.4	85.9	93.0	99.8	79.3	81.6	88.3	94.8	73.4	75.6	81.8	87.8
	S/T	0.83	0.75	0.56	0.36	0.86	0.77	0.58	0.38	0.89	0.79	0.60	0.39	0.91	0.82	0.62	0.40	0.95	0.85	0.64	0.41	0.96	0.86	0.65	0.42
	ΔT	20	19	15	11	21	19	16	11	21	19	16	11	21	19	16	11	20	19	15	11	19	18	14	10
	kW	6.24	6.36	6.55	6.75	6.69	6.82	7.03	7.25	7.08	7.23	7.45	7.69	7.43	7.59	7.83	8.07	7.73	7.89	8.14	8.40	7.99	8.16	8.42	8.69
	Amps	20.5	20.9	21.4	22.0	21.7	22.1	22.7	23.3	23.1	23.5	24.1	24.8	24.3	24.8	25.4	26.2	25.5	26.0	26.7	27.5	26.7	27.2	27.9	28.8
	Hi pr	236	254	268	280	265	285	301	314	301	324	342	357	343	369	390	407	386	415	439	458	427	459	485	506
	Lo Pr	109	116	127	135	116	123	134	143	120	128	139	149	126	134	146	156	132	141	154	163	137	145	159	169
	MBh	87.1	89.7	97.0	104.1	85.1	87.6	94.8	101.7	83.0	85.5	92.5	99.3	81.0	83.4	90.3	96.9	77.0	79.2	85.8	92.0	71.3	73.4	79.4	85.3
	S/T	0.79	0.71	0.54	0.35	0.82	0.74	0.56	0.36	0.84	0.76	0.57	0.37	0.87	0.78	0.59	0.38	0.90	0.81	0.61	0.39	0.91	0.82	0.62	0.40
	ΔT	21	20	16	11	21	20	16	11	21	20	16	11	22	20	16	11	21	20	16	11	20	18	15	10
	kW	6.19	6.32	6.50	6.70	6.64	6.77	6.98	7.19	7.03	7.17	7.39	7.63	7.38	7.53	7.76	8.01	7.67	7.83	8.08	8.34	7.92	8.09	8.35	8.62
	Amps	20.4	20.8	21.2	21.8	21.6	22.0	22.5	23.1	23.0	23.4	24.0	24.7	24.1	24.6	25.2	26.0	25.3	25.8	26.5	27.3	26.5	27.0	27.7	28.6
Hi pr	234	252	266	277	262	282	298	311	298	321	339	354	340	366	386	403	382	411	434	453	422	454	480	501	
Lo Pr	108	115	126	134	114	122	133	141	119	126	138	147	125	133	145	154	131	139	152	162	135	144	157	167	
MBh	80.4	82.7	89.6	96.1	78.5	80.8	87.5	93.9	76.6	78.9	85.4	91.7	74.8	77.0	83.3	89.4	71.0	73.1	79.2	85.0	65.8	67.7	73.3	78.7	
S/T	0.77	0.69	0.52	0.33	0.79	0.71	0.54	0.35	0.81	0.73	0.55	0.35	0.84	0.75	0.57	0.37	0.87	0.78	0.59	0.38	0.88	0.79	0.60	0.38	
ΔT	24	22	18	12	24	22	18	12	24	22	18	12	24	22	18	13	24	22	18	12	22	20	17	12	
kW	6.06	6.18	6.36	6.55	6.49	6.62	6.82	7.02	6.87	7.01	7.22	7.45	7.20	7.35	7.58	7.82	7.49	7.65	7.88	8.13	7.73	7.90	8.15	8.41	
Amps	20.0	20.3	20.8	21.4	21.2	21.5	22.0	22.7	22.5	22.9	23.5	24.1	23.6	24.1	24.7	25.4	24.8	25.3	25.9	26.7	25.9	26.4	27.1	27.9	
Hi pr	227	244	258	269	254	274	289	302	289	311	329	343	330	355	375	391	371	399	421	439	410	441	466	486	
Lo Pr	105	112	122	130	111	118	129	137	115	123	134	143	121	129	141	150	127	135	147	157	131	140	153	162	

* Entering Indoor Dry Bulb Temperature
 High pressure is measured at the liquid line gauge port connection
 Shaded area reflects ACCA (TVA) conditions
 Low pressure is measured at the compressor suction gauge port connection.

EXPANDED COOLING DATA — 7½ TONS (CONT.)

IDB*	Airflow	Outdoor Ambient Temperature																													
		65					75					85					95					105					115				
		59	63	67	71	75	59	63	67	71	75	59	63	67	71	75	59	63	67	71	75	59	63	67	71	75	59	63	67	71	75
80	3375	MBh	91.3	93.3	99.7	106.5	89.2	91.1	97.3	104.1	87.0	88.9	95.0	101.6	84.9	86.8	92.7	99.1	80.7	82.4	88.1	94.1	74.7	76.4	81.6	87.2					
		S/T	0.91	0.86	0.70	0.52	0.95	0.89	0.72	0.54	1.00	0.91	0.74	0.55	1.00	0.94	0.77	0.57	1.00	1.00	0.79	0.59	1.00	1.00	0.80	0.60					
		ΔT	23	22	19	15	23	22	19	15	24	22	19	15	23	22	19	15	22	22	19	15	20	21	18	14					
		kW	6.29	6.41	6.60	6.80	6.74	6.88	7.08	7.30	7.14	7.29	7.51	7.75	7.49	7.65	7.89	8.14	7.79	7.96	8.21	8.47	8.05	8.22	8.48	8.76					
		Amps	20.7	21.0	21.5	22.1	21.9	22.3	22.8	23.5	23.3	23.7	24.3	25.0	24.5	24.9	25.6	26.3	25.7	26.2	26.9	27.7	26.9	27.4	28.1	29.0					
	3000	Hi pr	238	257	271	283	268	288	304	317	304	328	346	361	347	373	394	411	390	420	443	462	431	464	490	511					
		Lo Pr	110	118	128	137	117	124	136	144	121	129	141	150	127	136	148	158	134	142	155	165	138	147	160	171					
		MBh	88.6	90.6	96.8	103.4	86.6	88.5	94.5	101.0	84.5	86.3	92.3	98.6	82.4	84.2	90.0	96.2	78.3	80.0	85.5	91.4	72.5	74.1	79.2	84.7					
		S/T	0.87	0.82	0.67	0.50	0.90	0.85	0.69	0.52	0.93	0.87	0.71	0.53	0.96	0.90	0.73	0.55	0.99	0.93	0.76	0.57	1.00	0.94	0.76	0.57					
		ΔT	24	23	20	16	24	23	20	16	24	23	20	16	24	23	20	16	24	23	20	16	22	21	19	15					
2400	kW	6.24	6.36	6.55	6.75	6.69	6.82	7.03	7.25	7.08	7.23	7.45	7.69	7.43	7.59	7.83	8.07	7.73	7.89	8.14	8.40	7.99	8.16	8.42	8.69						
	Amps	20.5	20.9	21.4	22.0	21.7	22.1	22.7	23.3	23.1	23.5	24.1	24.8	24.3	24.8	25.4	26.2	25.5	26.0	26.7	27.5	26.7	27.2	27.9	28.8						
	Hi pr	236	254	268	280	265	285	301	314	301	324	342	357	343	369	390	407	386	415	439	458	427	459	485	506						
	Lo Pr	109	116	127	135	116	123	134	143	120	128	139	149	126	134	147	156	132	141	154	164	137	145	159	169						
	MBh	81.8	83.6	89.3	95.5	79.9	81.6	87.2	93.2	78.0	79.7	85.1	91.0	76.1	77.8	83.1	88.8	72.3	73.9	78.9	84.4	67.0	68.4	73.1	78.1						
85	3375	S/T	0.84	0.79	0.64	0.48	0.87	0.82	0.67	0.50	0.89	0.84	0.68	0.51	0.92	0.86	0.70	0.53	0.96	0.90	0.73	0.55	0.97	0.91	0.74	0.55					
		ΔT	26	25	22	18	27	26	22	18	27	26	22	18	27	26	22	18	27	25	22	18	25	24	21	16					
		kW	6.10	6.22	6.40	6.60	6.54	6.67	6.87	7.08	6.92	7.06	7.28	7.50	7.26	7.41	7.64	7.88	7.55	7.71	7.95	8.20	7.80	7.96	8.21	8.48					
		Amps	20.1	20.5	21.0	21.5	21.3	21.7	22.2	22.8	22.6	23.1	23.6	24.3	23.8	24.2	24.9	25.6	25.0	25.4	26.1	26.9	26.1	26.6	27.3	28.1					
		Hi pr	229	246	260	271	257	277	292	305	292	315	332	346	333	358	378	395	375	403	426	444	414	445	470	490					
	3000	Lo Pr	106	113	123	131	112	119	130	139	116	124	135	144	122	130	142	151	128	136	149	159	133	141	154	164					
		MBh	92.9	94.7	99.2	105.8	90.7	92.5	96.8	103.3	88.6	90.3	94.5	100.9	86.4	88.1	92.2	98.4	82.1	83.7	87.6	93.5	76.0	77.5	81.2	86.6					
		S/T	0.96	0.92	0.83	0.68	0.99	0.96	0.86	0.70	1.00	0.98	0.89	0.72	1.00	1.00	0.92	0.74	1.00	1.00	0.95	0.77	1.00	1.00	0.96	0.78					
		ΔT	24	24	23	20	25	24	23	20	24	24	23	20	24	24	23	20	24	23	23	20	21	21	21	18					
		kW	6.33	6.46	6.65	6.85	6.79	6.93	7.14	7.36	7.19	7.34	7.57	7.81	7.55	7.71	7.95	8.20	7.85	8.02	8.27	8.54	8.12	8.29	8.55	8.83					
2400	Amps	20.8	21.2	21.7	22.3	22.0	22.4	23.0	23.6	23.4	23.9	24.5	25.2	24.7	25.1	25.8	26.5	25.9	26.4	27.1	27.9	27.1	27.6	28.4	29.2						
	Hi pr	241	259	274	285	270	291	307	320	307	331	349	364	350	377	398	415	394	424	448	467	435	468	495	516						
	Lo Pr	112	119	130	138	118	125	137	146	122	130	142	152	129	137	149	159	135	143	157	167	139	148	162	173						
	MBh	90.2	91.9	96.3	102.7	88.1	89.8	94.0	100.3	86.0	87.6	91.8	97.9	83.9	85.5	89.6	95.5	79.7	81.2	85.1	90.8	73.8	75.2	78.8	84.1						
	S/T	0.91	0.88	0.80	0.65	0.95	0.91	0.82	0.67	0.97	0.94	0.85	0.69	1.00	0.97	0.87	0.71	1.00	1.00	0.91	0.74	1.00	1.00	0.91	0.74						
85	3000	ΔT	25	25	23	20	26	25	24	21	26	25	24	21	26	25	24	21	24	25	24	20	23	23	22	19					
		kW	6.29	6.41	6.60	6.80	6.74	6.88	7.08	7.30	7.14	7.29	7.51	7.75	7.49	7.65	7.89	8.14	7.79	7.96	8.21	8.47	8.05	8.22	8.48	8.76					
		Amps	20.7	21.0	21.5	22.1	21.9	22.3	22.8	23.5	23.3	23.7	24.3	25.0	24.5	24.9	25.6	26.3	25.7	26.2	26.9	27.7	26.9	27.4	28.1	29.0					
		Hi pr	238	257	271	283	268	288	304	317	304	328	346	361	347	373	394	411	390	420	443	462	431	464	490	511					
		Lo Pr	110	118	128	137	117	124	136	144	121	129	141	150	127	136	148	158	134	142	155	165	138	147	160	171					
	2400	MBh	83.2	84.8	88.9	94.8	81.3	82.9	86.8	92.6	79.4	80.9	84.7	90.4	77.4	78.9	82.7	88.2	73.6	75.0	78.5	83.8	68.1	69.4	72.7	77.6					
		S/T	0.88	0.85	0.77	0.62	0.91	0.88	0.80	0.65	0.94	0.90	0.82	0.66	0.97	0.93	0.84	0.68	1.00	0.97	0.87	0.71	1.00	0.98	0.88	0.71					
		ΔT	28	28	26	23	28	28	26	23	28	28	26	23	29	28	27	23	28	28	26	23	26	26	25	21					
		kW	6.15	6.27	6.45	6.65	6.59	6.72	6.92	7.13	6.97	7.12	7.33	7.56	7.32	7.47	7.70	7.94	7.61	7.77	8.01	8.27	7.86	8.02	8.28	8.55					
		Amps	20.3	20.6	21.1	21.7	21.4	21.8	22.3	23.0	22.8	23.2	23.8	24.5	24.0	24.4	25.0	25.8	25.1	25.6	26.3	27.1	26.3	26.8	27.5	28.4					
85	Hi pr	231	249	263	274	260	279	295	308	295	318	335	350	336	362	382	399	378	407	430	448	418	450	475	495						
	Lo Pr	107	114	124	133	113	120	131	140	118	125	137	146	124	131	144	153	130	138	150	160	134	143	156	166						

* Entering Indoor Dry Bulb Temperature
High pressure is measured at the liquid line gauge port connection
Shaded area reflects ARI conditions
Low pressure is measured at the compressor suction gauge port connection.

EXPANDED COOLING DATA — 10 TONS

IDB		Outdoor Ambient Temperature																													
		65					75					85					95					105					115				
		Entering Indoor Wet Bulb Temperature																													
Airflow	59	63	67	71	59	63	67	71	59	63	67	71	59	63	67	71	59	63	67	71	59	63	67	71	59	63	67	71			
4500	MBh	115.6	119.8	131.3	-	112.9	117.1	128.3	-	110.3	114.3	125.2	-	107.6	111.5	122.1	-	102.2	105.9	116.0	-	94.7	98.1	107.5	-						
	S/T	0.74	0.62	0.43	-	0.77	0.64	0.45	-	0.79	0.66	0.46	-	0.82	0.68	0.47	-	0.85	0.71	0.49	-	0.85	0.71	0.49	-						
	ΔT	18	15	12	-	18	15	12	-	18	15	12	-	18	16	12	-	18	15	12	-	17	14	11	-						
	Hi Pr	247	265	280	-	277	298	314	-	315	339	358	-	358	386	407	-	403	434	458	-	446	479	506	-						
4000	Lo Pr	106	113	124	-	112	120	131	-	117	124	136	-	123	131	143	-	129	137	149	-	133	142	155	-						
	MBh	112.3	116.4	127.5	-	109.7	113.7	124.5	-	107.0	110.9	121.6	-	104.4	108.2	118.6	-	99.2	102.8	112.7	-	91.9	95.3	104.4	-						
	S/T	0.71	0.59	0.41	-	0.73	0.61	0.43	-	0.75	0.63	0.44	-	0.78	0.65	0.45	-	0.81	0.67	0.47	-	0.81	0.68	0.47	-						
	ΔT	18	16	12	-	19	16	12	-	19	16	12	-	19	16	12	-	18	16	12	-	17	15	11	-						
3200	Hi Pr	244	263	277	-	274	295	311	-	312	335	354	-	355	382	403	-	399	430	454	-	441	475	501	-						
	Lo Pr	105	112	122	-	111	118	129	-	116	123	134	-	122	129	141	-	127	135	148	-	132	140	153	-						
	MBh	103.6	107.4	117.7	-	101.2	104.9	114.9	-	98.8	102.4	112.2	-	96.4	99.9	109.5	-	91.6	94.9	104.0	-	84.8	87.9	96.3	-						
	S/T	0.68	0.57	0.40	-	0.71	0.59	0.41	-	0.73	0.61	0.42	-	0.75	0.63	0.43	-	0.78	0.65	0.45	-	0.78	0.66	0.45	-						
70	ΔT	20	18	13	-	21	18	14	-	21	18	14	-	21	18	14	-	20	18	13	-	19	17	13	-						
	Hi Pr	237	255	269	-	266	286	302	-	302	325	343	-	344	370	391	-	387	417	440	-	428	460	486	-						
	Lo Pr	102	109	119	-	108	115	125	-	112	119	130	-	118	125	137	-	124	131	143	-	128	136	148	-						

4500	MBh	117.6	121.1	131.0	140.6	114.9	118.3	128.0	137.4	112.1	115.4	125.0	134.1	109.4	112.6	121.9	130.8	103.9	107.0	115.8	124.3	96.3	99.1	107.3	115.1
	S/T	0.84	0.76	0.57	0.37	0.88	0.78	0.59	0.38	0.90	0.80	0.61	0.39	0.93	0.83	0.63	0.40	0.96	0.86	0.65	0.42	0.97	0.87	0.66	0.42
	ΔT	20	19	15	11	21	19	16	11	21	19	16	11	21	19	16	11	20	19	15	11	19	18	14	10
	Hi Pr	249	268	283	295	280	301	318	331	318	342	361	377	362	390	411	429	407	438	463	483	450	484	511	533
4000	Lo Pr	107	114	125	133	114	121	132	140	118	126	137	146	124	132	144	153	130	138	151	161	134	143	156	166
	MBh	114.2	117.5	127.2	136.6	111.5	114.8	124.3	133.4	108.9	112.1	121.3	130.2	106.2	109.3	118.4	127.0	100.9	103.9	112.4	120.7	93.5	96.2	104.2	111.8
	S/T	0.81	0.72	0.55	0.35	0.84	0.75	0.57	0.36	0.86	0.77	0.58	0.37	0.88	0.79	0.60	0.38	0.92	0.82	0.62	0.40	0.93	0.83	0.63	0.40
	ΔT	21	19	16	11	21	20	16	11	21	20	16	11	22	20	16	11	21	20	16	11	20	18	15	10
3200	Hi Pr	247	265	280	292	277	298	315	328	315	339	358	373	358	386	407	425	403	434	458	478	446	480	506	528
	Lo Pr	106	113	124	132	112	120	131	139	117	124	136	145	123	131	143	152	129	137	149	159	133	142	155	165
	MBh	105.4	108.5	117.4	126.0	102.9	106.0	114.7	123.1	100.5	103.4	112.0	120.2	98.0	100.9	109.2	117.2	93.1	95.9	103.8	111.4	86.3	88.8	96.1	103.2
	S/T	0.78	0.69	0.53	0.34	0.81	0.72	0.55	0.35	0.83	0.74	0.56	0.36	0.85	0.76	0.58	0.37	0.88	0.79	0.60	0.39	0.89	0.80	0.60	0.39
75	ΔT	24	22	18	12	24	22	18	12	24	22	18	12	24	22	18	13	24	22	18	12	22	20	17	12
	Hi Pr	239	257	272	284	268	289	305	318	305	329	347	362	348	374	395	412	391	421	445	464	432	465	491	512
	Lo Pr	103	110	120	128	109	116	127	135	113	121	132	140	119	127	138	147	125	133	145	154	129	137	150	160

IDB = Entering Indoor Dry Bulb Temperature Design Superheat 7±2 °F; Design Subcooling 12 ±2 °F pressures measured @ the suction and liquid access fittings; ARI 95° test conditions
 High and low pressures are measured at the liquid and suction service access fittings. Shaded area reflects ACCA (TVA) conditions

EXPANDED COOLING DATA — 10 TONS (CONT.)

IDB		Outdoor Ambient Temperature																													
		65					75					85					95					105					115				
		Entering Indoor Wet Bulb Temperature																													
Airflow	59	63	67	71	59	63	67	71	59	63	67	71	59	63	67	71	59	63	67	71	59	63	67	71	59	63	67	71			
4500	MBh	119.7	122.3	130.7	139.7	116.9	119.4	127.6	136.4	114.1	116.6	124.6	133.2	111.3	113.8	121.5	129.9	105.8	108.1	115.5	123.4	98.0	100.1	107.0	114.3						
	S/T	0.93	0.87	0.71	0.53	0.96	0.90	0.73	0.55	1.00	0.92	0.75	0.56	1.00	0.95	0.78	0.58	1.00	1.00	0.81	0.60	1.00	1.00	0.81	0.61						
	ΔT	23	22	19	15	23	22	19	15	23	22	19	15	23	22	19	15	22	22	19	15	20	20	18	14						
	Hi Pr	252	271	286	298	282	304	321	335	321	346	365	381	366	394	416	433	411	443	468	488	455	489	517	539						
80	Lo Pr	109	116	126	134	115	122	133	142	119	127	138	147	125	133	145	155	131	140	152	162	136	144	158	168						
	MBh	116.2	118.7	126.9	135.6	113.5	116.0	123.9	132.4	110.8	113.2	121.0	129.3	108.1	110.4	118.0	126.1	102.7	104.9	112.1	119.8	95.1	97.2	103.8	111.0						
	S/T	0.88	0.83	0.67	0.50	0.92	0.86	0.70	0.52	0.94	0.88	0.72	0.54	0.97	0.91	0.74	0.55	1.00	0.94	0.77	0.57	1.00	0.95	0.77	0.58						
	ΔT	24	23	20	16	24	23	20	16	24	23	20	16	24	23	20	16	24	23	20	16	22	21	18	15						
3200	Hi Pr	249	268	283	295	280	301	318	331	318	342	361	377	362	390	412	429	407	438	463	483	450	484	511	533						
	Lo Pr	107	114	125	133	114	121	132	140	118	126	137	146	124	132	144	153	130	138	151	161	134	143	156	166						
	MBh	107.2	109.6	117.1	125.2	104.8	107.0	114.4	122.3	102.3	104.5	111.6	119.3	99.8	101.9	108.9	116.4	94.8	96.8	103.5	110.6	87.8	89.7	95.8	102.5						
	S/T	0.85	0.80	0.65	0.49	0.88	0.83	0.67	0.50	0.91	0.85	0.69	0.52	0.93	0.88	0.71	0.53	0.97	0.91	0.74	0.55	0.98	0.92	0.75	0.56						
85	ΔT	26	25	22	17	27	25	22	18	27	25	22	18	27	26	22	18	26	25	22	18	25	24	21	16						
	Hi Pr	242	260	275	286	271	292	308	321	308	332	350	366	351	378	399	416	395	425	449	468	437	470	496	517						
	Lo Pr	104	111	121	129	110	117	128	136	114	122	133	142	120	128	140	149	126	134	146	156	130	139	151	161						
	MBh	121.8	124.1	130.0	138.7	118.9	121.2	127.0	135.5	116.1	118.4	124.0	132.2	113.3	115.5	120.9	129.0	107.6	109.7	114.9	122.6	99.7	101.6	106.4	113.5						
4500	S/T	0.97	0.94	0.85	0.69	1.00	0.97	0.88	0.71	1.00	1.00	0.90	0.73	1.00	1.00	0.93	0.75	1.00	1.00	0.96	0.78	1.00	1.00	0.97	0.79						
	ΔT	24	24	22	19	24	24	23	20	24	24	23	20	23	24	23	20	22	22	23	20	20	21	21	18						
	Hi Pr	254	273	289	301	285	307	324	338	324	349	369	384	369	398	420	438	416	447	472	493	459	494	522	544						
	Lo Pr	110	117	127	136	116	123	135	143	120	128	140	149	126	135	147	156	133	141	154	164	137	146	159	170						
85	MBh	118.2	120.5	126.2	134.7	115.5	117.7	123.3	131.5	112.7	114.9	120.3	128.4	110.0	112.1	117.4	125.3	104.5	106.5	111.5	119.0	96.8	98.7	103.3	110.2						
	S/T	0.93	0.89	0.81	0.65	0.96	0.93	0.84	0.68	0.98	0.95	0.86	0.70	1.00	0.98	0.89	0.72	1.00	1.00	0.92	0.75	1.00	1.00	0.93	0.75						
	ΔT	25	25	23	20	25	25	24	21	26	25	24	21	25	25	24	21	24	24	24	20	22	23	22	19						
	Hi Pr	252	271	286	298	282	304	321	335	321	346	365	381	366	394	416	433	411	443	468	488	455	489	517	539						
3200	Lo Pr	109	116	126	134	115	122	133	142	119	127	138	147	125	133	145	155	131	140	152	162	136	144	158	168						
	MBh	109.1	111.2	116.5	124.3	106.6	108.6	113.8	121.4	104.0	106.1	111.1	118.5	101.5	103.5	108.4	115.6	96.4	98.3	103.0	109.8	89.3	91.1	95.4	101.7						
	S/T	0.89	0.86	0.78	0.63	0.93	0.89	0.81	0.65	0.95	0.92	0.83	0.67	0.98	0.95	0.85	0.69	1.00	0.98	0.89	0.72	1.00	0.99	0.89	0.72						
	ΔT	28	28	26	23	28	28	26	23	28	28	26	23	29	28	27	23	28	28	26	23	26	26	24	21						
85	Hi Pr	244	263	277	289	274	295	311	325	311	335	354	369	355	382	403	420	399	430	454	473	441	475	501	523						
	Lo Pr	105	112	122	130	111	118	129	138	116	123	134	143	121	129	141	150	127	135	148	157	132	140	153	163						

IDB = Entering Indoor Dry Bulb Temperature Design Superheat 7±2 °F, Design Subcooling 12 ±2 °F, pressures measured @ the suction and liquid access fittings; ARI 95° test conditions
 High and low pressures are measured at the liquid and suction access fittings. Shaded area reflects ARI Rating conditions

DIMENSIONS

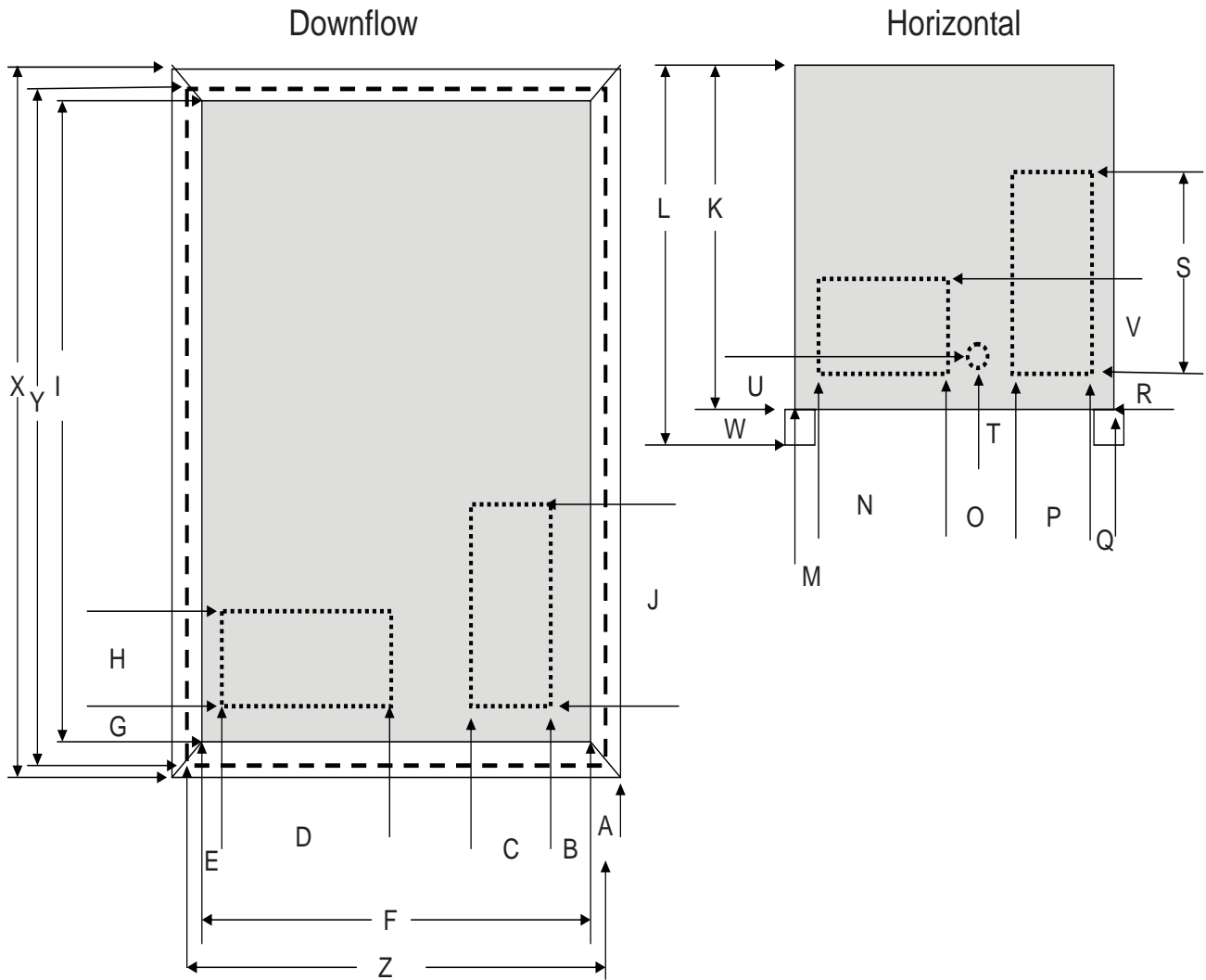

Point	Dimension (")
A	3½
B	4½
C	12 ⁵ / ₈
D	28 ⁵ / ₁₆
E	4
F	54¾
G	3
H	14
I	92 ¹⁵ / ₁₆
J	36 ³ / ₈
K	48 ³ / ₈
L	52 ⁷ / ₈
M	6 ¹³ / ₁₆

Point	Dimension (")
N	28 ³ / ₈
O	7 ³ / ₈
P	12 ⁵ / ₈
Q	5 ⁷ / ₈
R	1¾
S	36 ³ / ₈
T	5
U	15½
V	13 ⁷ / ₈
W	4½
X	99¾
Y	99 ¹ / ₈
Z	61

UNIT CLEARANCES

Maintain an adequate clearance around the unit for safety, service, maintenance, and proper unit operation. Leave a total clearance of 75" on the main control panel side of the unit for possible removal of fan shaft, coil, electric heat, and gas furnace. Leave a clearance of 48" on all other sides of the unit for possible compressor removal or service access, and to ensure proper ventilation and condenser airflow. Do not install the unit beneath any obstruction. Install the unit away from all building exhausts to inhibit ingestion of exhaust air into the unit's fresh-air intake.

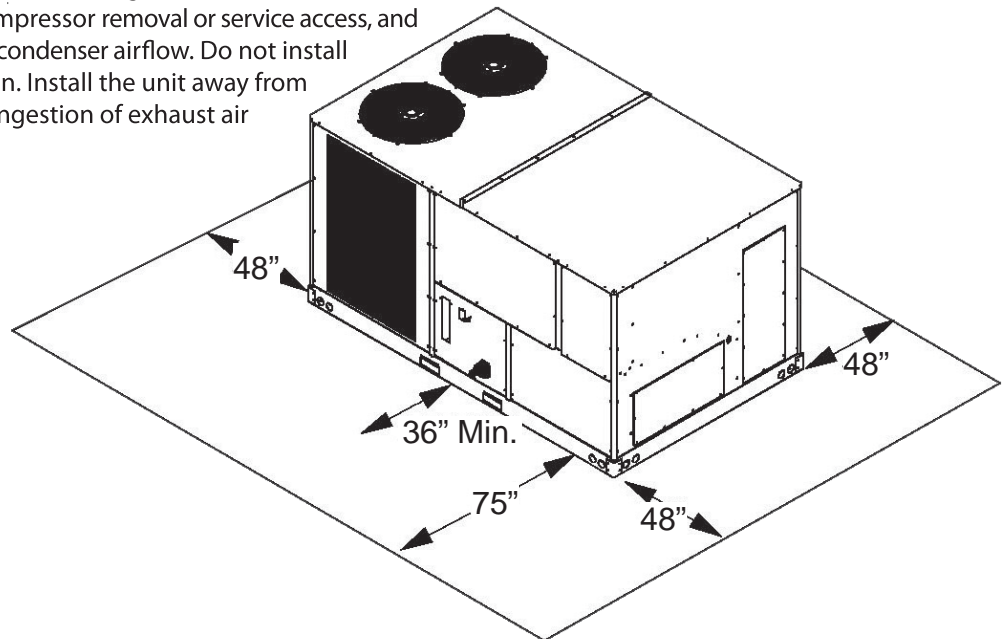

ELECTRICAL ENTRANCE LOCATIONS

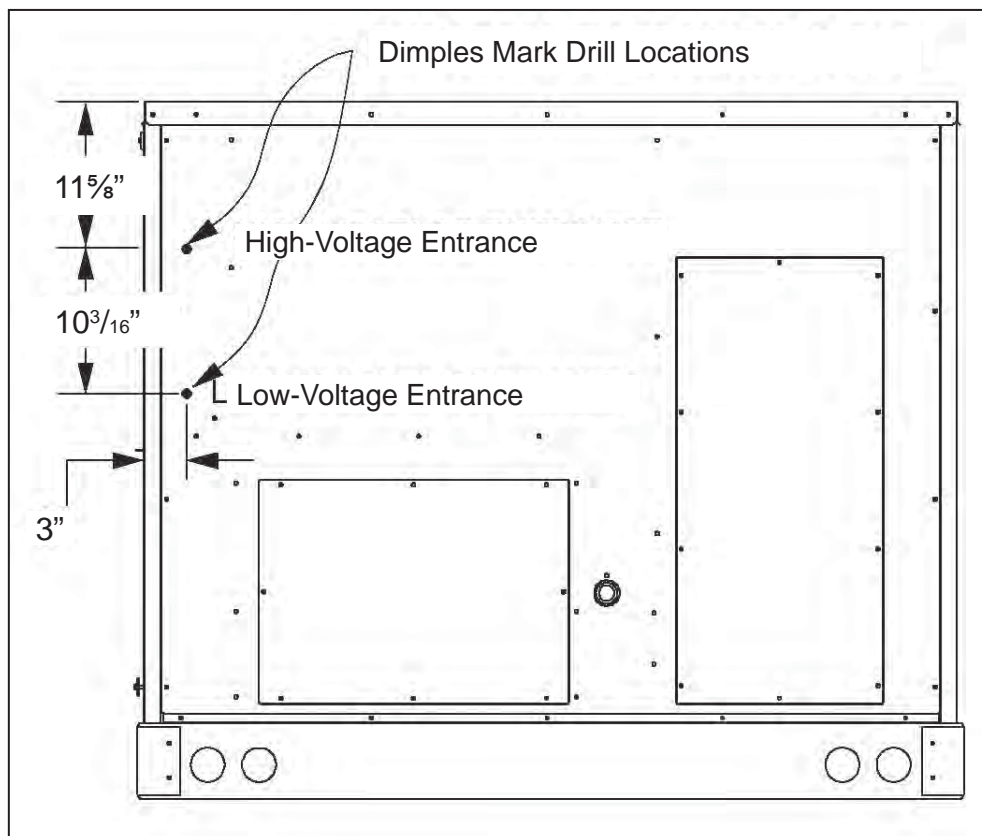

ROOF CURB INSTALLATION — RIGGING

Provisions for forks have been included in the unit base frame. No other fork locations are approved.

- Unit must be lifted by the four lifting holes located at the base frame corners.
- Lifting cables should be attached to the unit with shackles.
- The distance between the crane hook and the top of the unit must not be less than 60”.
- Two spreader bars must span over the unit to prevent damage to the cabinet by the lift cables. Spreader bars must be of sufficient length so that cables do not come in contact with the unit during transport. Remove wood struts mounted beneath unit base frame before setting unit on roof curb. These struts are intended to protect unit base frame from fork lift damage. To remove the struts, extract the sheet metal retainers and pull the struts through the base of the unit. Refer to rigging label on the unit.

Important: If using bottom discharge with roof curb, duct-work should be attached to the curb prior to installing the unit. Duct-work dimensions are shown in Roof Curb Installation Instructions Manual.

Refer to the Roof Curb Installation Instructions for proper curb installation. Curbing must be installed in compliance with the National Roofing Contractors Association Manual.

Lower unit carefully onto roof mounting curb. While rigging the unit, the center of gravity will cause the condenser end to be lower than the supply air end.

Bring condenser end of unit into alignment with the curb. With condenser end of the unit resting on curb member and using curb as a fulcrum, lower opposite end of the unit until entire unit is seated on the curb. When a rectangular cantilever curb is used, take care to center the unit. Check for proper alignment and orientation of supply and return openings with duct.

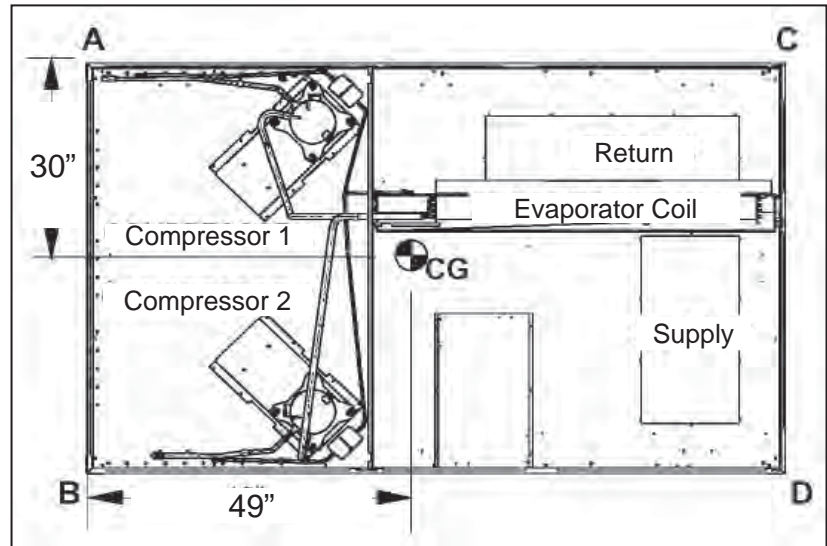
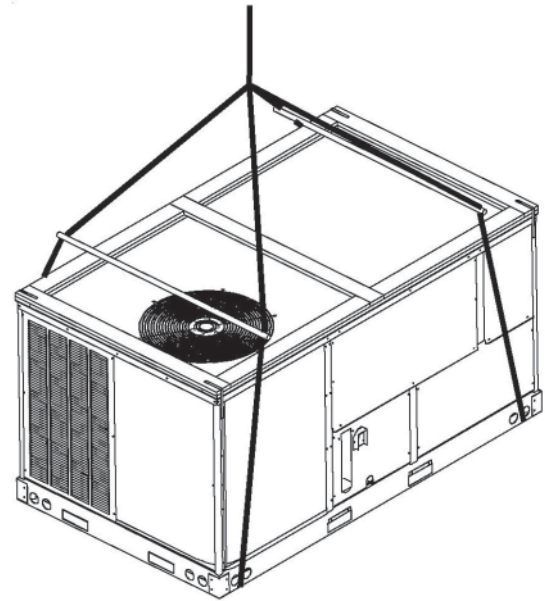

Corner & Center-of-Gravity Locations

To assist in determining rigging requirements, unit weights are shown to the right.

Note: These weights are calculated without accessories installed.

Weight Types	7½-Ton Weights (lbs)	10-Ton Weights (lbs)
Weight A	225	230
Weight B	325	330
Weight C	275	280
Weight D	400	405
Shipping Weight	1250	1275
Operating Weight	1210	1235

ROOF CURB INSTALLATION (CONT.)

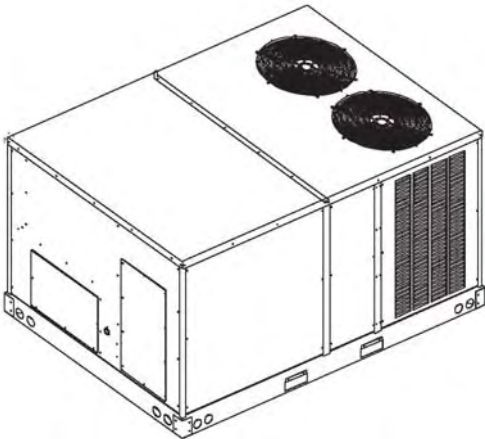

Curb installations must comply with local codes and should follow the established guidelines of the National Roofing Contractors Association.

Proper unit installation requires that the roof curb be firmly and permanently attached to the roof structure. Check for adequate fastening method prior to setting the unit on the curb.

Full perimeter roof curbs are available from the factory and are shipped unassembled. The installing contractor is responsible for field assembly, squaring, leveling, and mounting on the roof structure. All required hardware necessary for the assembly of the sheet metal curb is included in the curb accessory package.

- Determine sufficient structural support before locating and mounting the curb and package unit.
- Duct-work must be constructed using industry guidelines. The duct-work must be placed into the roof curb before mounting the package unit. Our full perimeter curbs include duct connection frames to be assembled with the curb. Cantilevered-type curbs are not available from the factory.

3-D VIEW

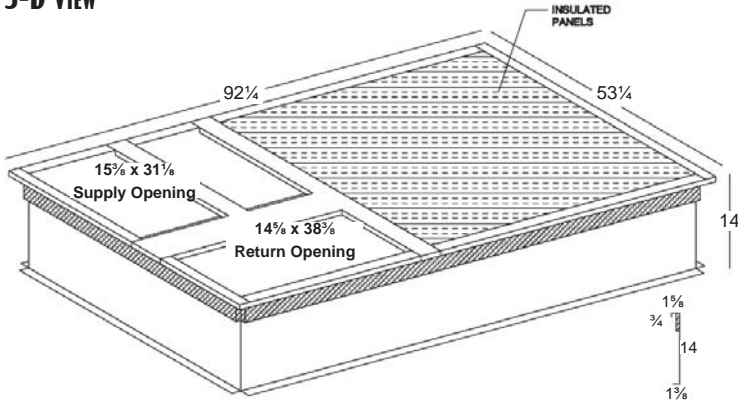

- Contractor furnishes curb insulation, cant strips, flashing, and general roofing material.
- Support curbs on parallel sides with roof members. To prevent damage to the unit, the roof members cannot penetrate supply and return duct openings.

Note: The unit and curb accessories are designed to allow vertical duct installation before unit placement. Duct installation after unit placement is not recommended.

See the manual shipped with the roof curb for assembly and installation instructions.

TOP VIEW

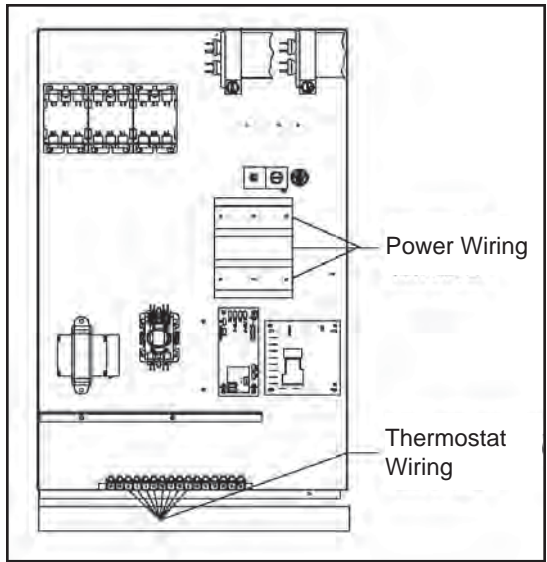
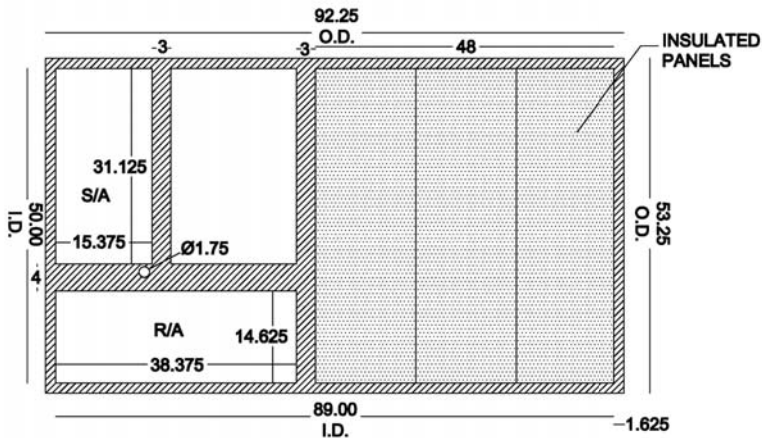

POWER AND LOW-VOLTAGE BLOCK LOCATIONS

WIRING DIAGRAM — CPG090/120**3B** (THREE-PHASE BELT DRIVE)

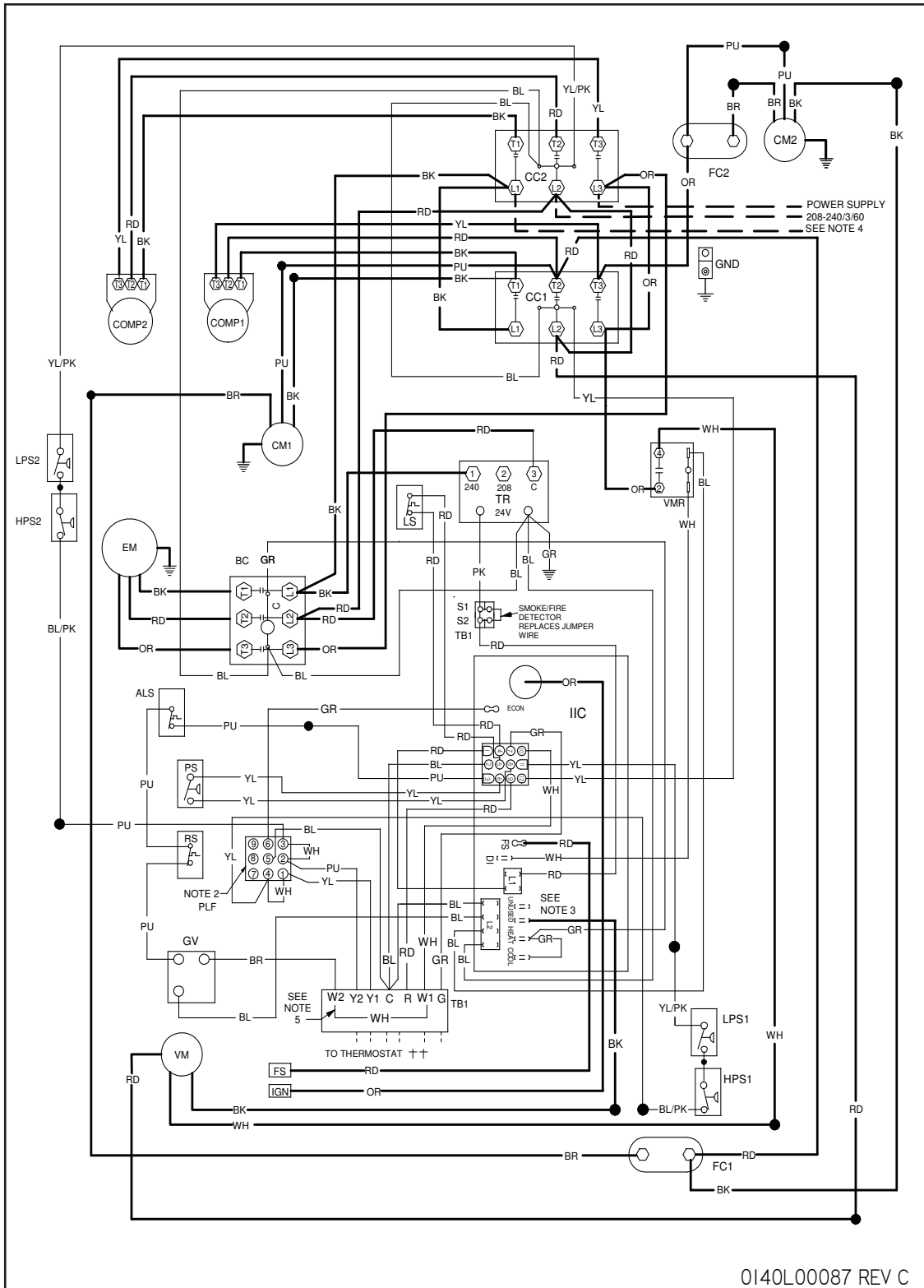



High Voltage:
Disconnect all power before servicing or installing this unit. Multiple power sources may be present. Failure to do so may cause property damage, personal injury, or death.

WARNING



Wiring is subject to change. Always refer to the wiring diagram on the unit for the most up-to-date wiring.

WIRING DIAGRAM — CPG090/120*3B** (THREE-PHASE BELT DRIVE) CONT.

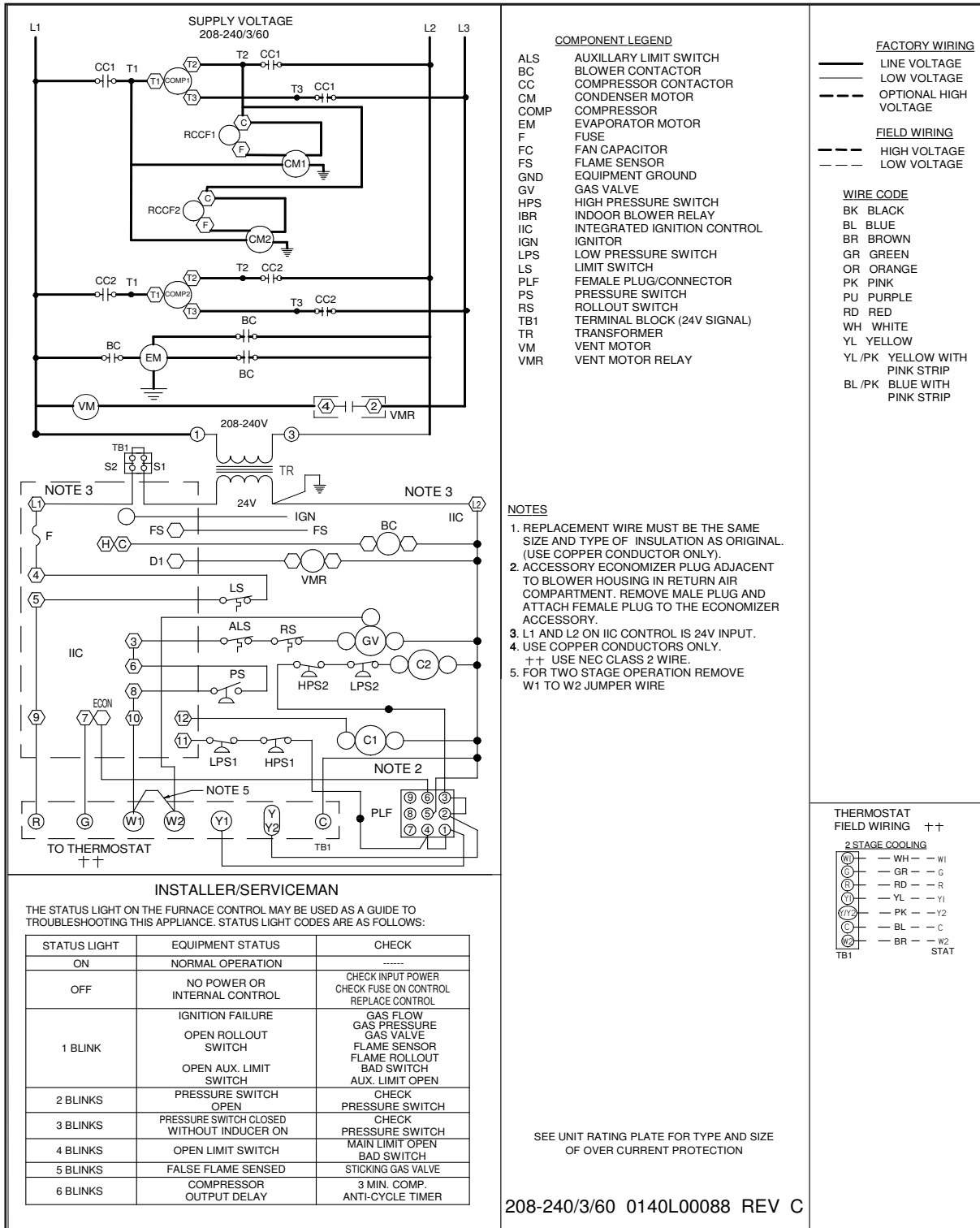

Wiring is subject to change. Always refer to the wiring diagram on the unit for the most up-to-date wiring.



WARNING

High Voltage:
Disconnect all power before servicing or installing this unit. Multiple power sources may be present. Failure to do so may cause property damage, personal injury, or death.



WIRING DIAGRAM — CPG090/120*4B/7B** (460V / 575V BELT DRIVE)

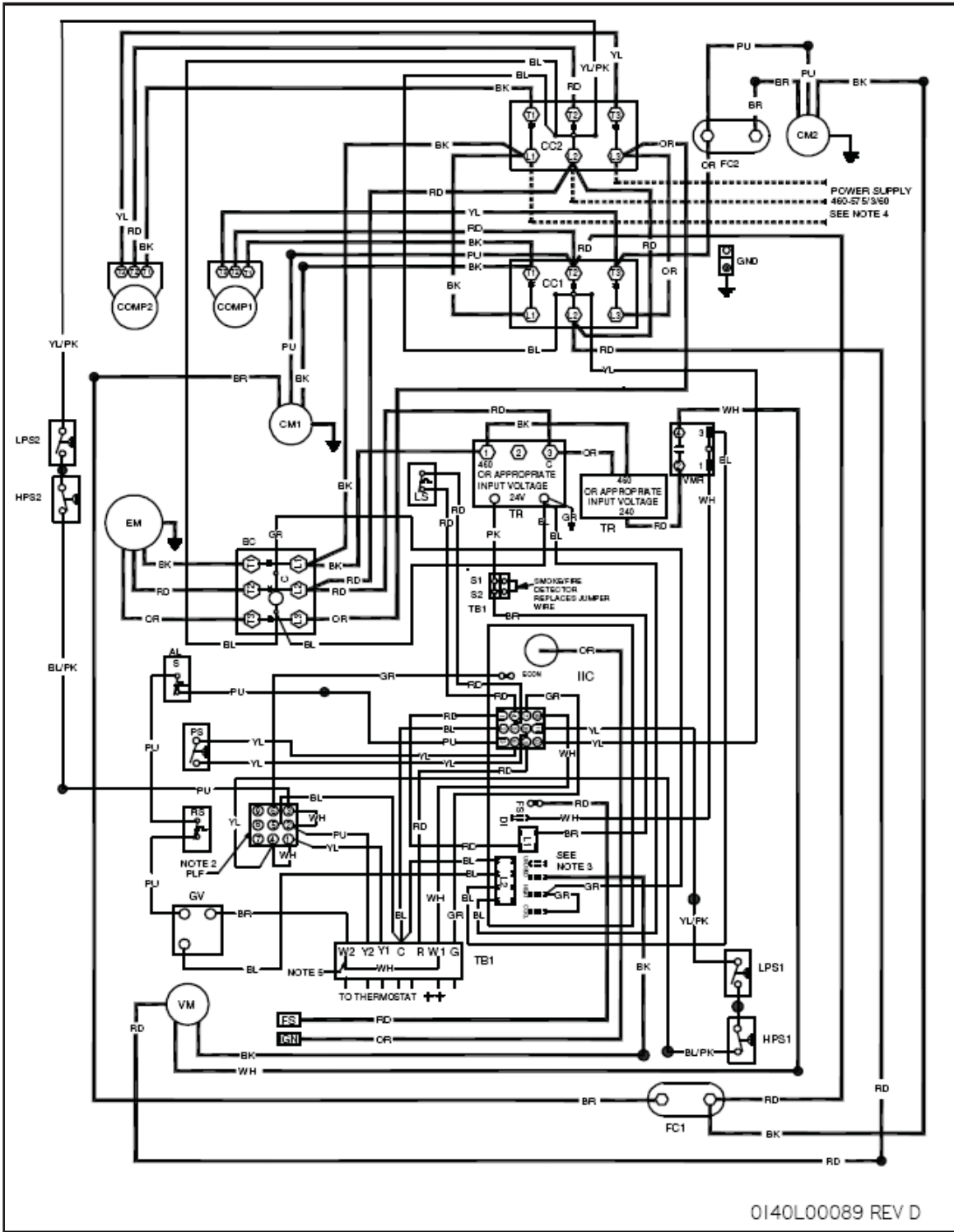



Wiring is subject to change. Always refer to the wiring diagram on the unit for the most up-to-date wiring.

 WARNING	<p>High Voltage: Disconnect all power before servicing or installing this unit. Multiple power sources may be present. Failure to do so may cause property damage, personal injury, or death.</p>	
--	---	---

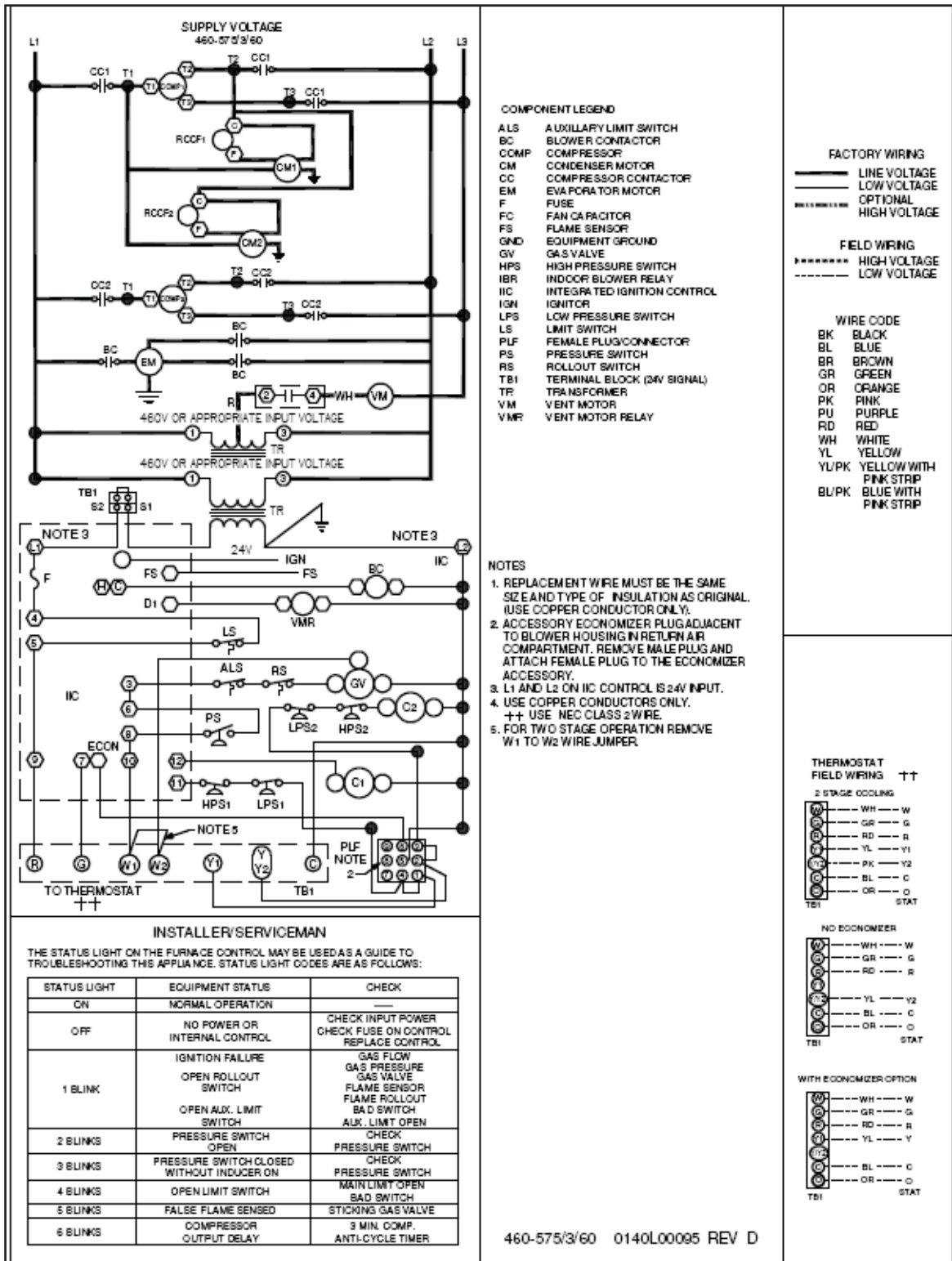
WIRING DIAGRAM — CPG090/120*4B/7B** (460V / 575V BELT DRIVE) CONT.



High Voltage: Disconnect all power before servicing or installing this unit. Multiple power sources may be present. Failure to do so may cause property damage, personal injury, or death.

 **WARNING**

Wiring is subject to change. Always refer to the wiring diagram on the unit for the most up-to-date wiring.

ACCESSORIES

Item #	Description	Fits Model Sizes	Package Dimensions ("	Ship Weight
14CURB90150	Roof Curb 14" Tall	7½-12½ tons	16 x 6 x 94	160
25FD90150	25% Manual Fresh Air Damper	7½-12½ tons	13 x 15½ x 37½	11
25MFD90150	25% Motorized Fresh Air Damper	7½-12½ tons	13 x 15½ x 37½	12
DNSQRRND90	Downflow Square-to-Round Adapter 20" Round	7½ tons	15 x 37½ x 10	16
HZECONGS90150	Horizontal Economizer for CPC/CPG	7½-12½ tons	21 x 21 x 48	110
BRD3672	Horizontal Barometric Relief Damper	7½-12½ tons		
CDK120	Concentric Duct Kit	10 tons		
CDK150	Concentric Duct Kit	12½ tons		
CDK90102	Concentric Duct Kit	7½-8½ tons	31 x 48 x 18	55
DNECONGS90150	Downflow Economizer for CPC/CPG	7½-12½ tons	40 x 20 x 41	135
HailGD02	Condenser Coil Hail Guard	7½ - 10 tons	64 x 52 x 2	
HAKT36300	High-Altitude Kit	All Models		
HSKT090	High Static Kit	7½ tons		
HSKT120	High Static Kit	10 tons		
LPKT36150	LP Conversion Kit	3 - 12½ tons		

