

Installation Instructions

PGF3 Series

PACKAGED GAS / ELECTRIC UNITS



TABLE OF CONTENTS

UNIT DIMENSIONS	2	ORIFICES	6
SAFE INSTALLATION REQUIREMENTS	3	ELECTRICAL WIRING	7
LOCATING THE UNIT	3	DUCTWORK	9
CLEARANCES	3	FILTERS	9
INSTALLATION	3	AIRFLOW ADJUSTMENT	10
GROUND LEVEL INSTALLATION	4	START-UP PROCEDURES	11
HOISTING	4	GAS PRESSURES	12
DOWNFLOW CONVERSION	4	HEATING START-UP PROCEDURES	12
HEATING VENT ASSEMBLY	4	OPERATION	13
CONDENSATE DRAIN	4	MAINTENANCE	13
PRE-EXISTING COMMON VENT CHECK	5	INSPECTION AND CLEANING	14
COMBUSTION BLOWER PIPE INSTALLATION	5	RIGGING	16
GAS SUPPLY AND PIPING	5	WIRING DIAGRAMS	17 - 18



Unit Wiring Diagrams on pages 17 & 18.

1. UNIT DIMENSIONS

1-1/2 TO 3-1/2 TON

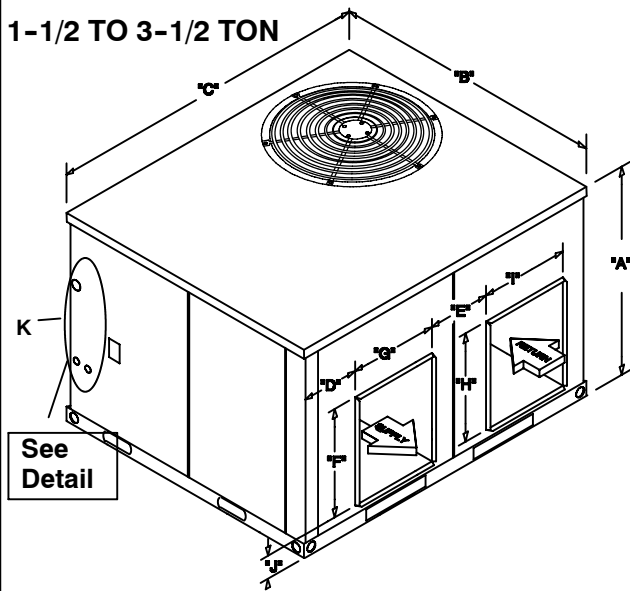

4 TO 5 TON

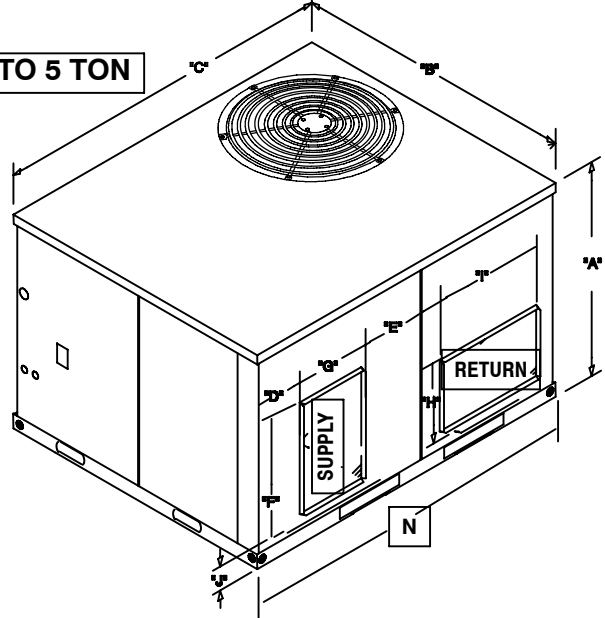

BASE PAN - CHASSIS

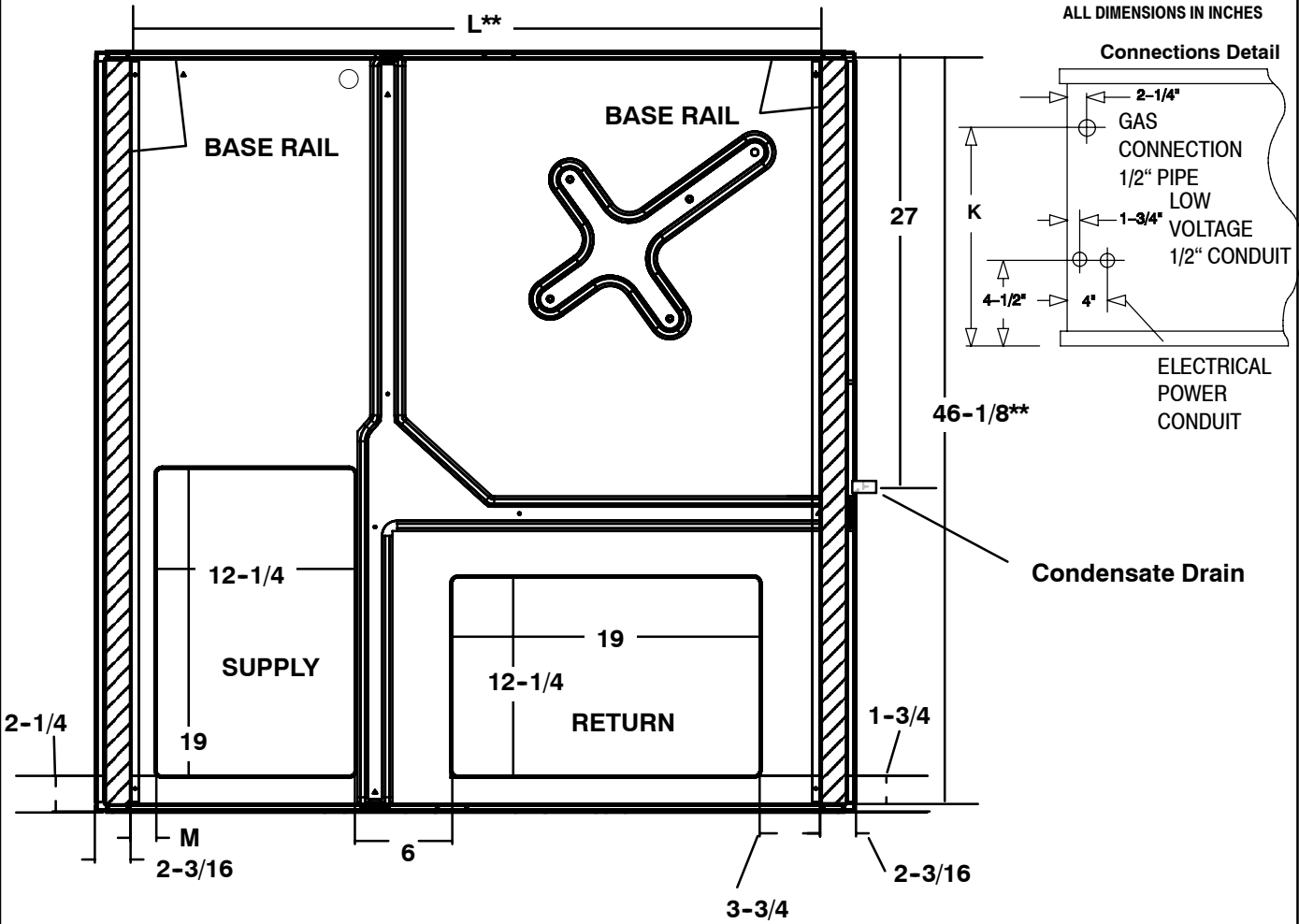

ALL DIMENSIONS IN INCHES

Connections Detail

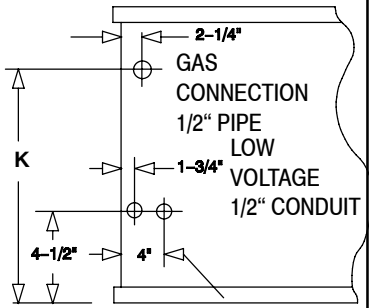

ELECTRICAL POWER CONDUIT

CONDENSATE DRAIN

UNIT SIZE	A	B	C	D	E	F	G	H	I	J	K	L	M	N
2 Ton	29-1/2	47-1/2	47-1/2	3	9-1/2	12	14	12	14	4-1/2	16	42-3/4	1-9/16	46-1/2
2-1/2 TO 3-1/2 Ton	37-1/2	47-1/2	47-1/2	3	9-1/2	12	14	12	14	4-1/2	22	42-3/4	1-9/16	46-1/2
4 TO 5 Ton*	37-1/2	47-1/2	51-1/2	7-1/2	6-1/2	19	12	12	19	4-1/2	22	46-1/4	5-3/16	49-3/4

** Measured from inside to inside on base rails.

2. SAFE INSTALLATION REQUIREMENTS

⚠ WARNING
FIRE, EXPLOSION, ELECTRICAL SHOCK, AND CARBON MONOXIDE POISON HAZARD

Failure to carefully read and follow all instructions in this manual could result in furnace malfunction, property damage, personal injury and/or death.

Installation or repairs made by unqualified persons can result in hazards to you and others. Installation **MUST** conform with local building codes or, in the absence of local codes, with the National Fuel Gas Code NFPA 54-2005/ANSI Z223.1-2005 and the National Electrical Code NFPA70-2005 or in Canada the National Standard CAN/CGA B149-1 and CSA C.22.1 - Canadian Electrical Code Part 1.

The information contained in this manual is intended for use by a qualified service technician familiar with safety procedures and equipped with the proper tools and test instruments.

- Do **NOT** use this furnace as a construction heater.
- Use only the Type of gas approved for this furnace (See **Rating Plate**).
- Do **NOT** use open flame to test for gas leak.
- Seal supply and return air ducts.
- Check to see that filters are installed correctly and are the proper type and size.

NOTE: It is the personal responsibility and obligation of the customer to contact a qualified installer to ensure that the installation is adequate and conforms to governing codes and ordinances.

⚠ CAUTION
UNIT SAFETY

Failure to follow this caution may reduce unit reliability. It is recommended that a qualified service technician check the heat exchanger integrity every two (2) years, after the first four (4) years of operation.

3. LOCATING THE UNIT

ACCESS PANELS

See **FIGURE 1** for a general view of unit and location of access panels.

⚠ WARNING
CARBON MONOXIDE POISONING HAZARD.

Failure to follow this warning could result in bodily injury and/or death.

Keep blower door closed.

CLEARANCES

The location **MUST** allow for minimum clearances and should not be adjacent to a patio or other area where the unit's operating sound level might be objectionable. The combustion air inlet openings **MUST** not be obstructed (see **FIGURE 1**). In addition, local codes **MUST** be observed.

NOTE: Units with available filter racks (3-1/2 to 5 ton), need a 26" minimum clearance at side of unit for removal of filters. See chart below if unit is going to be placed near combustible construction or materials.

While minimum clearances are acceptable for safety reasons, they may not allow adequate air circulation around the unit for proper operation in the cooling mode. Whenever possible, it is desirable to allow additional clearance, especially around the condenser inlet and discharge openings.

Do **NOT** install the unit in a location that will permit discharged air from the condenser to recirculate to the condenser inlet.

⚠ CAUTION
UNIT DAMAGE HAZARD

Failure to follow this caution may result in shorten life of unit components.

Do **NOT** operate unit in a corrosive atmosphere containing chlorine, fluorine, or any other corrosive chemicals.

Minimum Clearances to Combustible Construction

Furnace Plenum	2"
Duct Side	2"
Condenser Inlet	30"
Blower Service (Side)	30"
Control Service Side	
(Front Combustion Air Inlet)	30"
Clearance between 3 Ft. Overhang	
and Top of Unit	30"
Combustible Base	
(Wood or Class A, B or C	
roof covering material)	0"

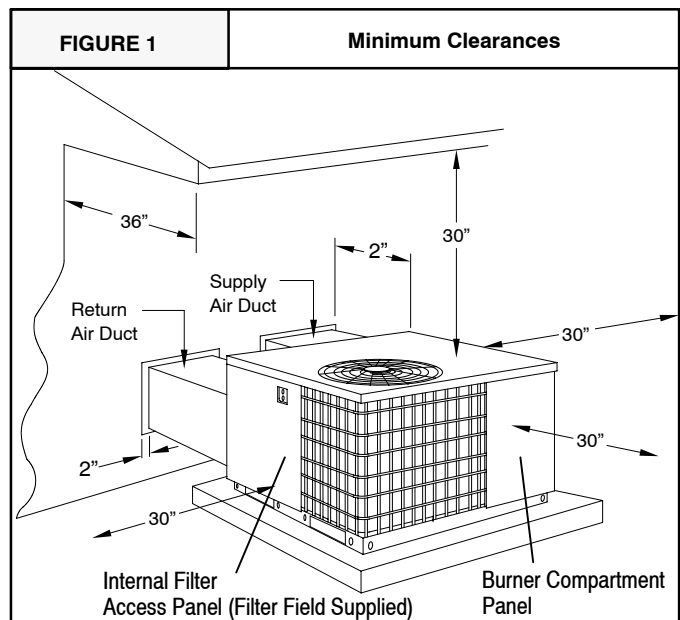

INSTALLATION

NOTICE

Unit will **NOT** operate properly unless it is installed level front to rear and side to side. The slope **MUST NOT** be greater than 1/8" per foot (10mm per meter). For side to side leveling, the drain side **MUST** always be lower.

Ground Level Installation

Ground level platform requirements:

- The unit **MUST** be situated to provide safe access for servicing.
- Platform may be made of either concrete or pressure treated wood and **MUST** be level and strong enough to support unit weight.
- Position platform separate from building foundation.
- Install in well-drained area, with top surface of platform above grade level.
- Platform must be high enough to allow for proper condensate trap installation and drainage. See **FIGURE 3** and associated text for more information about condensate drainage.

Rooftop Installation

Rooftop platform requirements:

- The unit **MUST** be situated to provide safe access for servicing.
- The existing roof structure **MUST** be adequate to support the weight of the unit or the roof **MUST** be reinforced. Check the weight of the unit in relation to the roof structure and local building codes or ordinances and reinforce roof structure if necessary. See the last page of this manual for unit weights.
- Support for the unit **MUST** be level and strong enough to carry unit weight. The support may consist of a platform or a combination of platform and roof beams or curb.
- See *Hoisting* section for hoisting instructions.

HOISTING

NOTE: All access panels **MUST** be secured in place before hoisting.

The unit should be hoisted with two lifting slings. Attach the slings to rigging shackles that have been hooked through holes in the base rail.

Two spreader bars **MUST** be placed on top of the unit to protect the unit from damage from the pressure exerted by the slings. Make sure that all equipment is adequate to handle the weight of the unit and that the slings will not allow the unit to shift.

Refer to **FIGURE 19** on the back cover of this manual for illustrated rigging instructions and weight chart.

DOWNFLOW CONVERSION

NOTE: In downflow applications with roof curbs or jack stands, the center rail under the unit must be removed. The center rail is attached to the base rail with screws.

These units are adaptable to downflow use. To convert to downflow use, follow these steps:

1. Remove the blockoff plates found in the return air compartment and the supply air compartment.

NOTE: Blockoff plate in the supply air compartment only contains one screw. If reinstalling plate, back part of plate **MUST** fit into mating dimples on flange. To reinstall, slant plate into dimples, then put plate into position and fasten with screw.

2. Install the removed plates on the horizontal return and supply air openings.
3. Install roof curb on the building. Be sure to follow all directions included with curb and all applicable building codes in your installation.

Heating Vent Assembly

Refer to **FIGURE 2** and assemble as shown.

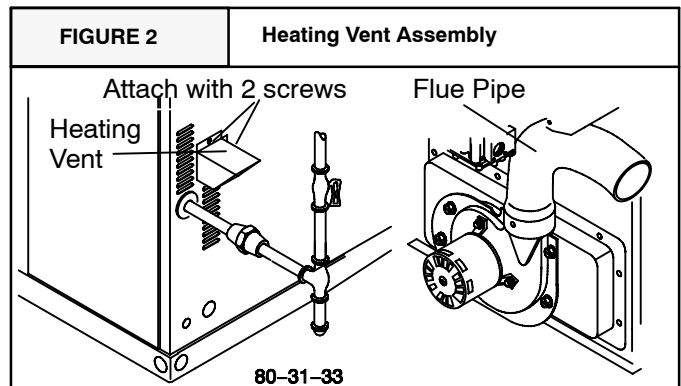

CAUTION	
UNIT DAMAGE Failure to follow this caution may result in unit damage. Do not operate the unit without the vent assembly installed.	

Condensate Drain

The condensate drain outlet is a $\frac{3}{4}$ " (19.1mm) female PVC connection located at the bottom on the left hand side (see **FIGURE 3**).

The circulating blower creates a negative pressure on the condensate drain line that can prevent the condensate from draining properly. To combat this negative pressure, a field supplied condensate trap that will allow a standing column of water of at least 2" (50.8mm) **MUST** be installed. Top of outlet from trap **MUST** be at least 1" (25.4mm) below top of outlet from unit. **Install the trap as near to the unit as possible for proper drainage.**

A $\frac{3}{4}$ " (19.1mm) drain line **MUST** be installed if required by local codes or if location of unit requires it. Run the drain line to an open drain or other suitable disposal point.

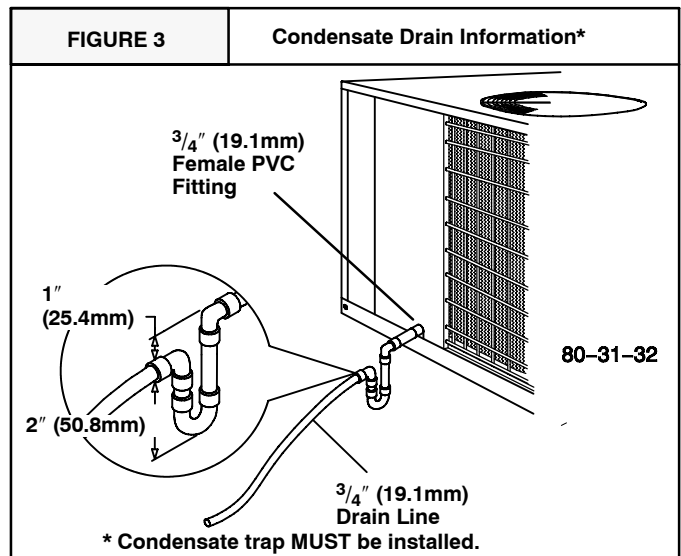

4. PRE-EXISTING COMMON VENT CHECK

If the installation of this new combination gas heat/electric cool unit involves removing an existing gas-fired furnace from a common vent system with other gas-fired appliances (gas-fired hot water heater, etc.), the existing vent system must be checked and inspected by a qualified technician. The qualified technician can determine if the existing vent system will properly vent the flue products of the remaining gas-fired appliances. In many cases, the existing vent system may be oversized for the remaining appliances.

Combustion Blower Pipe Installation

Remove the combustion blower pipe from the right corner of the burner compartment and position the end of the pipe with the screw hole over the opening of the combustion blower. The other end of the pipe should now be aligned through the opening in the side panel of the unit. The pipe should slightly protrude through the opening in the side panel.

Remove (1) chisel pointed #10 screw (self-drilling) taped to the vent cap. Position the screw to the hole in the pipe and drill through the combustion blower outlet securing the pipe to the combustion blower.

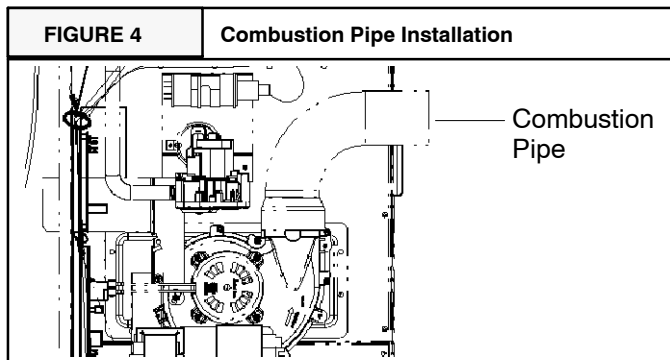

5. GAS SUPPLY AND PIPING

NOTE: Because there are many types of liquified petroleum (LP) gases, the term LP as used in this manual refers to *propane* gas. If you intend to use any type of LP gas, proper precautions **MUST** be used in the handling, piping, and use of such gas. **NOTE:** In Canada, installations **MUST** be performed by licensed LP installers.

The UL rating plate located on the side panel on the unit contains the model number, type of gas, gas input rating, and other important information.

⚠ WARNING

FIRE OR EXPLOSION HAZARD
Failure to follow this warning could result in property damage, personal injury, and/or death.

Make certain the unit is equipped to operate on the type of gas available. Models designated as natural gas are to be used with natural gas only. Models designated for use with liquefied petroleum (LP) gas are shipped with orifices sized for commercially pure propane gas. They **MUST** not be used with butane or a mixture of butane and propane unless properly sized orifices are installed by a licensed LP installer.

GAS PIPING

The gas supply line **MUST** be of adequate size to handle the Btu/hr requirements and length of the run for the unit being installed. Determine the minimum pipe size for natural gas from the table in **FIGURE 5** or **FIGURE 6**. Base the length of the run from the gas meter or source to the unit.

Gas Pipe Size

Btu ratings of all other gas appliances **MUST** be considered for sizing of main gas line. Check gas line to installation for compliance with local codes or, in the absence of local codes, with the National Fuel Gas Code NFPA 54-2005/ANSI Z223.1-2005 or in Canada the National Standard CAN/CGA B149-1 or current editions.

FIGURE 5		Gas Pipe Size, Length and Btu/hr Capacity for Schedule 40 Iron Pipe (English)				
NATURAL GAS						
Pipe Length (Includes Fittings)	Btu/hr (in thousands)					
	3/4"	1"	1 1/4"	1 1/2"	2"	
20'	190	350	730	1,100	2,100	
40'	130	245	500	760	1,450	
60'	105	195	400	610	1,150	
LP GAS						
Pipe Length (Includes Fittings)	Btu/hr (in thousands)					
	1/2"	3/4"	1"	1 1/4"	1 1/2"	
20'	189	393	732	1,496	2,299	
40'	129	267	504	1,039	1,559	
60'	103	217	409	834	1,275	

FIGURE 6		Gas Pipe Size, Length and Btu/hr Capacity for Schedule 40 Iron Pipe (English)				
NATURAL GAS						
Pipe Length (Includes Fittings)	kW**					
	3/4"	1"	1 1/4"	1 1/2"	2"	
6.1m	56	103	214	322	615	
12.2m	38	72	147	223	425	
18.3m	31	57	117	179	337	
LP GAS						
Pipe Length (Includes Fittings)	kW**					
	1/2"	3/4"	1"	1 1/4"	1 1/2"	
6.1m	55	115	215	438	674	
12.2m	38	78	148	305	457	
18.3m	30	64	120	244	374	

**kW (Kilowatts) is the metric equivalent of Btu/hr.

PIPING AT UNIT

Connections

NOTE: The rules listed apply to natural and LP gas pipe installations.

1. If installation is for LP gas, have LP gas installer use **TWO-STAGE REGULATION** and make all connections from storage tank to unit.
2. Use black iron or steel pipe and fittings or other pipe approved by local code.
3. If copper tubing is used, it **MUST** comply with limitation set in Fuel Gas Code.

NOTE: If a gas connector is used, it **MUST** be acceptable to local authority. Connector **MUST NOT** be used inside the furnace or be secured or supported by the furnace or ductwork.

⚠ WARNING
FIRE OR EXPLOSION HAZARD
 Failure to do so could result in personal injury, death and/or property damage.
 Gas connector **MUST** be properly installed and can **NOT** be used inside the furnace.

4. Use pipe joint compound on external (male) threads **ONLY**. Joint compound **MUST** be resistant to any chemical action of LP gases. Do **NOT** put pipe compound on last 2 threads of pipe.
5. Use ground joint unions and install a drip leg no less than 3 inches (76 mm) long to trap dirt and moisture before it can enter gas valve.

⚠ CAUTION
UNIT OPERATION AND COMPONENT DAMAGE HAZARD
 Failure to follow this caution may result in misaligned burners, flame rollout and or unit damage.
 Overtightening assembly may cause damage to the gas valve and/or wiring and may misalign the burners.

6. Use a wrench on gas valve when making connections to prevent gas valve from turning. Do **NOT** use a pipe wrench on the gas valve body.
7. Provide a 1/8 inch (3mm) National Pipe Thread (NPT) plug for test gauge connection immediately upstream of the gas supply connection to the furnace if none is supplied with the gas valve of unit.
8. Install a manual shutoff valve and tighten all joints securely.

ORIFICES

Orifice Sizes

Orifice sizes **MUST** be matched to the heating value of the gas (see **TABLE 1 & 2**). Check with your gas supplier and the National Fuel Gas Code ANSI Z223.1.

NOTE: An LP Conversion Kit **MUST** be used for conversion to LP gas.

NOTE: For elevations above 2000 feet (610 meters), the Btu input rating **MUST** be reduced by 4% for each 1000 feet (305 meters) above sea level, unless the gas supplier's Btu/ft³ content has already been adjusted for altitude. Check **Table 1 & 2** for the proper orifice sizes.

TABLE 1 & 2: Equivalent Orifice Sizes at High Altitudes

Table 1	NATURAL GAS ORIFICE SIZING								
	MEAN ELEVATION FEET ABOVE SEA LEVEL								
	0 to 2000		2001 to 4000	4001 to 5000	5001 to 6000	6001 to 7000	7001 to 8000	8001 to 9000	9001 to 10000
Nominal Heating Size	Orifice Drill #	Kit Number	Orifice Drill #	Orifice Drill #	Orifice Drill #	Orifice Drill #	Orifice Drill #	Orifice Drill #	Orifice Drill #
040, 060, 080	44	1173863	45	46	47	47	48	48	49
100	41	1173865	43	43	43	44	44	45	46
120, 140	42	1173865	43	43	44	44	45	46	47

NOTE: The orifice sizes in the chart above derate the input rate at 4% per 1000 feet above sea level for altitudes exceeding 2000 feet above sea level. If converting from LP gas to Natural Gas at altitudes exceeding 2000 feet above sea level, use part number 330732-401, plus the required orifice size # shown in Table 1. Natural Gas data is based on 0.60 specific gravity, a heating value of 1030 Btu/Cu.Ft., and 3.5" W.C. manifold pressure. For fuels with different specific gravity, consult the National Fuel Gas Code NFPA 54-2005/ANSI Z223.1-2005 or National Standard of Canada, Natural Gas and Propane Installation Code CSA B149.1-05.

Table 2	LP GAS ORIFICE SIZING									
	MEAN ELEVATION FEET ABOVE SEA LEVEL									
	0 to 2000		2001 to 4000		4001 to 7000		7001 to 9000		9001 to 10,000	
Nominal Heating Size	Orifice Drill #	Kit Number	Orifice Drill #	Kit Number	Orifice Drill #	Kit Number	Orifice Drill #	Kit Number	Orifice Drill #	Kit Number
040, 060, 080	55	1173857	55	1173857	56	1173859	56	1173859	57	1173861
100, 120, 140	54	1173855	55	1173857	55	1173857	56	1173859	56	1173859

NOTE: The orifice sizes in the chart above derate the input rate at 4% per 1000 feet above sea level for altitudes exceeding 2000 feet above sea level. LP Gas data is based on 1.52 specific gravity, a heating value of 2500 Btu/Cu.Ft., and 10.0" W.C. manifold pressure. For fuels with different specific gravity, consult the National Fuel Gas Code NFPA 54-2005/ANSI Z223.1-2005 or National Standard of Canada, Natural Gas and Propane Installation Code CSA B149.1-05.

Changing Orifices

⚠ WARNING

ELECTRICAL SHOCK, FIRE AND/OR EXPLOSION HAZARD

Failure to follow this warning could result in property damage, personal injury, and/or death.

Shut off electric power at unit disconnect or service panel and shut off gas at manual shut off valve before beginning the following procedure.

Changing orifices requires a qualified service technician.

1. Shut **OFF** gas at manual shut off valve.
2. Shut **OFF** electric power at unit disconnect or service panel. If unit is still running, allow 3 minutes after gas shut off before turning off power.
3. Disconnect the wires from the gas valve, sparker, and flame sensor.
4. Remove the four screws holding the manifold to the manifold brackets.
5. Carefully remove the manifold with the gas valve attached.
6. If unit has v-shaped NOx baffles installed in the firing tubes, they must be removed. Some baffles may be attached by screws. Replace screws after removing NOx baffles (figure 7).

⚠ WARNING

CARBON MONOXIDE HAZARD.

Failure to follow this warning could result in property damage, personal injury and/or death.

NOx baffles for use with Natural Gas units **ONLY**. If LP Gas is required, NOx inserts must be removed.

FIGURE 7

Removing NOx Baffles

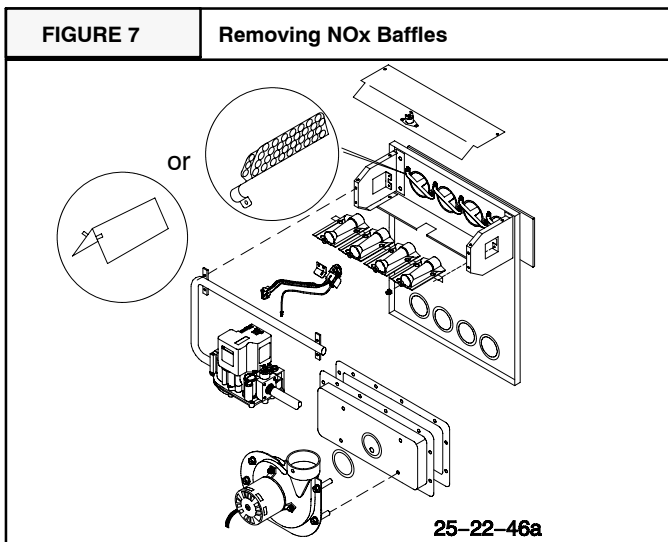

7. Remove the orifices from the manifold with a $\frac{7}{16}$ " box end or socket wrench.
8. Check to be sure that the size of each orifice is correct for the Btu input desired.

FIGURE 8

Manifold/Orifice Measurement

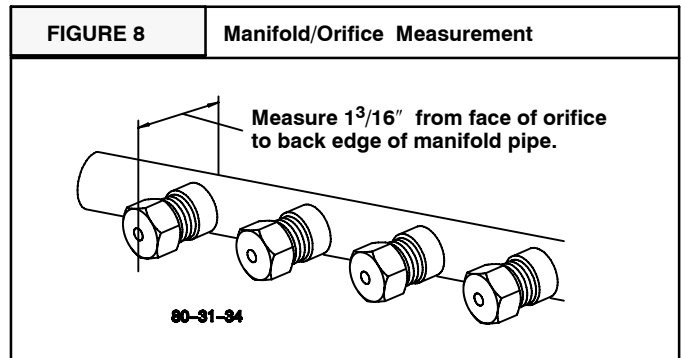

9. Install the correct orifices. Gauge the size of the orifices with a new twist drill bit of the correct size.

Make sure that the orifices go in straight so that they form a right angle (90°) to the manifold pipe.

Tighten the orifices so that there is a $1\frac{3}{16}$ " distance between the faces of the orifices to the back of the manifold pipe.

Measure the distance with a set of calipers. If you do not have a calipers, you can use an adjustable wrench and measure between the face of the jaws.

10. Reassemble in reverse order.

6. ELECTRICAL WIRING

⚠ WARNING

ELECTRICAL SHOCK HAZARD.

Failure to follow this warning could result in property damage, personal injury, and/or death.

The unit cabinet must have an uninterrupted, unbroken electrical ground to minimize the possibility of serious injury if an electrical fault should occur. This ground may consist of an electrical wire connected to the unit ground lug in the control compartment, or conduit approved for electrical ground when installed in accordance with National Electric Code (NEC) NFPA 70, National Fuel Gas Code NFPA 54-2005/ANSI Z223.1-2005 and local electrical codes. In Canada, follow Canadian Electrical Code CSA (Canadian Standards Association) C22.1 and local electrical codes. Failure to adhere to this warning could result in serious injury or death.



CAUTION

REDUCED EQUIPMENT LIFE HAZARD

Failure to follow these precautions could result in damage to the unit being installed.

- 1) Make all electrical connections in accordance with National Electric code (NEC) NFPa 70, National Fuel Gas Code NFPA 54-2005/ANSI Z223.1-2005 and local electrical codes governing such wiring. In Canada, all electrical connections must be in accordance with CSA standard C22.1, Canadian Electrical Code Part 1, and applicable local codes. Refer to unit wiring diagram.
- 2) Use only copper conductor for connections between field-supplied electrical disconnect switch and unit. **DO NOT USE ALUMINUM WIRE.**
- 3) Be sure that high-voltage power to unit is within operating voltage range indicated on unit rating plate.
- 4) Do not damage internal components when drilling through any panel to mount electrical hardware, conduit, etc. Consult local power company for correction of improper voltage and/or phase imbalance.

For access, remove the burner access panel. See **FIGURE 1** for access panel location. Wiring **MUST** be protected from possible mechanical damage.

Disconnect Switch

The unit must have separate electrical service with a field-supplied, waterproof, disconnect switch mounted at, or within sight from, the unit. Refer to the unit rating plate for maximum fuse/circuit breaker size and minimum circuit amps (ampacity) for wire sizing.

Ground Connections

Do **NOT** complete line voltage connections until unit is permanently grounded. All line voltage connections and the ground connection **MUST** be made with copper wire.

A ground lug is installed in the control box area for the ground connection. Use a copper conductor of the appropriate size from the unit to a grounded connection in the electrical service panel or a properly driven and electrically grounded ground rod. See warning above.

Line Voltage Wiring

Connections for line voltage are made in the unit control box area. Refer to wiring diagram located on the Burner Access panel. For access, remove the burner access panel.

1. Run the high voltage (L1, L2) and ground leads into the control box.
2. Connect ground lead to chassis ground connection.
3. Connect L1 to pressure lug connection 11 of the compressor contactor.
4. Connect L2 to pressure lug connection 23 of the compressor contactor.

Thermostat / Low Voltage Wiring

Location of the thermostat has an important effect on home comfort. FOLLOW THE THERMOSTAT INSTRUCTION MANUAL FOR CORRECT LOCATION, MOUNTING, AND WIRING.

For 2 to 3-1/2 Ton Models Only:

A single stage thermostat is required for proper operation. Thermostat must have the following terminals: "R", "W", "Y", and "G". Some electronic thermostats use low voltage from the unit for power for temperature display and programming. These electronic thermostats will have a "C" terminal. The outdoor unit has color-coded wires for easy connection. Using wire nuts, follow figure 9 for proper connections:

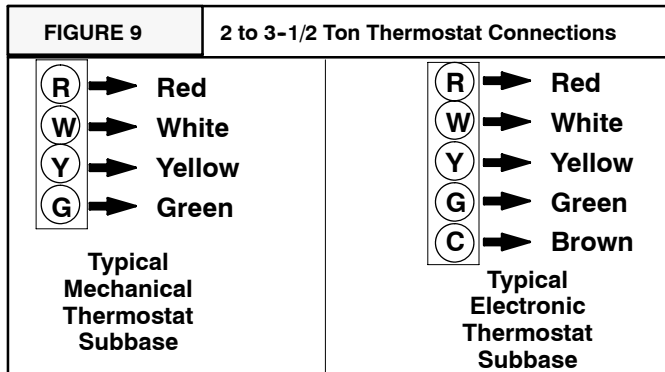

For 4 to 5 Ton Models Only:

A two-stage thermostat is required for proper operation. Thermostat should have the following terminals: "R", "W/W1", "Y1", "Y2", and "G". Some electronic thermostats use low voltage from the unit for power for temperature display and programming. These electronic thermostats will have a "C" terminal. The outdoor unit has color-coded wires for easy connection. Using wire nuts, follow figure 10 for proper connections:

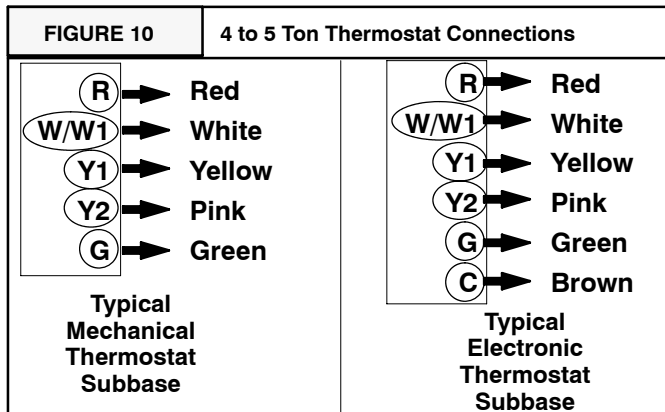

THERMOSTAT HEAT ANTICIPATOR

Some thermostats have an adjustable heat anticipator. The heat anticipator prevents temperature overshoot in heating mode. If the heat doesn't turn off until the set point temperature on the thermostat is exceeded, then the anticipator setting is too low. If the heat turns off before the thermostat reaches the set point temperature on the thermostat, then the anticipator setting is too high. Follow the thermostat instruction manual for proper adjustment of the heat anticipator.

Final Electrical Check

1. Make a final wiring check to be sure system is correctly wired. Inspect field installed wiring and the routing to ensure that rubbing or chafing due to vibration will not occur.

NOTE: Wiring **MUST** be installed so it is protected from possible mechanical damage.

7. DUCTWORK

Ductwork Sizing

The maximum recommended velocity in trunk ducts is 1000 feet per minute. The maximum recommended velocity in branch ducts is 800 feet per minute.

Ductwork sizing affects the discharge temperature, airflow velocity, and efficiency of the system. Be sure to properly size ductwork to the capacity of the unit and to the airflow requirements of the conditioned space. Failure to properly size ductwork can result in inadequate airflow and poor efficiency. Undersized ductwork may result in tripped limit controls and premature failure of compressors, motors and other components.

Ductwork Insulation

Ductwork installed outdoors must have a minimum 2" thick fiberglass "wrap" insulation and a weatherproof vapor barrier installed around it. The insulation and vapor barrier must be protected against potential damage. Caulking, flashing, and other means of providing a permanent weather seal must be used.

Ductwork Connections

The use of flexible, non-combustible connectors between main trunk ducts and supply and return air plenums is

permitted. If flexible connectors are used, they should be protected from potential mechanical damage such as punctures and tears.

NOTE: When connecting the supply and return plenums to the unit, make sure that the plenums are sealed against the side casing of the unit and do not interfere with removal of the top of the unit.

FILTERS

All return air **MUST** pass through a filter before entering the unit. An electronic air cleaner, optional filter racks, or other accessible filter arrangement must be installed in the return air ductwork. Minimum recommended filter sizes are listed in FIGURE 10 and are based on maximum face velocities of 300 ft/min for disposable filters and 600 ft/min for washable (high velocity) filters. See figure 10 for filter sizes.

⚠ CAUTION

REDUCED EQUIPMENT LIFE HAZARD

Failure to follow this caution may result in improper unit operation.

Do not operate the unit without a filter.

FIGURE 11		Filter Sizes		
Model	Disposable Filters		Washable Filters ¹	
	Nominal Size (qty x w x d)	Minimum Area (sq. inches)	Nominal Size (w x d) (inches)	Minimum Area (sq. inches)
PGF324040K****	1 x 20" x 20"	384	1 x 10" x 20"	192
PGF324060K****	1 x 20" x 24"	480	1 x 12" x 20"	240
PGF330060K****	1 x 20" x 24"	480	1 x 12" x 20"	240
PGF330080K****	2 x 15" x 20"	576	1 x 15" x 20"	288
PGF336060K****	2 x 15" x 20"	576	1 x 15" x 20"	288
PGF336080K****	2 x 15" x 20"	576	1 x 15" x 20"	288
PGF336100K****	2 x 18" x 20"	720	1 x 18" x 20"	360
PGF342080K****	2 x 18" x 20"	672	1 x 18" x 20"	336
PGF342100K****	2 x 18" x 20"	720	1 x 18" x 20"	360
PGF348080K****	2 x 20" x 20"	768	1 x 20" x 20"	384
PGF348120K****	2 x 20" x 20"	785	1 x 20" x 20"	393
PGF354100K****	2 x 20" x 24"	960	1 x 20" x 24"	480
PGF354140K****	2 x 24" x 24"	1008	1 x 24" x 24"	504

¹ Washable filter size is based on an allowable face velocity of 600 ft/min. Refer to filter manufacturer's specifications for allowable face velocity and required filter area.

8. AIRFLOW ADJUSTMENT



WARNING

ELECTRICAL SHOCK HAZARD.

Failure to follow this warning could result in property damage, personal injury, and/or death.

Turn off electric power supply at disconnect switch or service panel before removing access or service panels from unit.

PGF3 SERIES HEATING CHART																							
					External Static Pressure (in H ₂ O)																		
					.1"			.2"			.3"			.4"			.5"			.6"			.7"
Model	Cooling Tons	Heating Input (Btu/hr)	Heating Rise Range (°F)	Speed Tap	CFM	Heating Rise (°F)	CFM	Heating Rise (°F)	CFM	Heating Rise (°F)	CFM	Heating Rise (°F)	CFM	Heating Rise (°F)	CFM	Heating Rise (°F)	CFM	Heating Rise (°F)	CFM	Heating Rise (°F)			
PGF324040K****	2	40000	30 - 60	4	1211	NA	1175	NA	1134	NA	1086	NA	1044	NA	985	30	841	35	604	49			
				3	1136	NA	1098	NA	1056	NA	1020	NA	980	30	920	32	785	38	569	52			
				2	968	31	927	32	885	33	859	34	790	37	735	40	657	45	524	57			
				1	891	33	845	35	804	37	758	39	707	42	649	46	582	51	509	58			
PGF324060K****	2	60000	30 - 60	4	1211	37	1175	38	1134	39	1086	41	1044	43	985	45	841	53	604	NA			
				3	1136	39	1098	40	1056	42	1020	44	980	45	920	48	785	57	569	NA			
				2	968	46	927	48	885	50	859	52	790	56	735	NA	657	NA	524	NA			
				1	891	50	845	53	804	55	758	59	707	NA	649	NA	582	NA	509	NA			
PGF330060K****	2.5	60000	30 - 60	4	1352	33	1311	34	1274	35	1233	36	1203	37	1162	38	1119	40	1066	41			
				3	1268	35	1225	36	1186	37	1158	38	1129	39	1085	41	1044	42	1004	44			
				2	1076	41	1038	43	997	44	973	45	913	48	875	51	840	53	786	56			
				1	986	45	949	47	908	49	856	52	819	54	781	57	717	NA	664	NA			
PGF330080K****	2.5	80000	35 - 65	4	1352	44	1311	45	1274	46	1233	48	1203	49	1162	51	1119	53	1066	55			
				3	1268	47	1225	48	1186	50	1158	51	1129	52	1085	54	1044	57	1004	59			
				2	1076	55	1038	57	997	59	973	61	913	65	875	NA	840	NA	786	NA			
				1	986	60	949	62	908	65	856	NA	819	NA	781	NA	717	NA	664	NA			
PGF336060K****	3	60000	30 - 60	4	1652	NA	1607	NA	1574	NA	1541	NA	1500	NA	1462	30	1426	31	1384	32			
				3	1529	NA	1484	30	1440	31	1402	32	1364	32	1326	33	1284	34	1238	36			
				2	1278	35	1233	36	1191	37	1149	38	1108	40	1060	42	1005	44	943	47			
				1	1162	38	1118	40	1062	42	1014	44	958	46	892	50	826	54	780	57			
PGF336080K****	3	80000	35 - 65	4	1652	36	1607	37	1574	38	1541	38	1500	39	1462	40	1426	41	1384	43			
				3	1529	39	1484	40	1440	41	1402	42	1364	43	1326	45	1284	46	1238	48			
				2	1278	46	1233	48	1191	50	1149	51	1108	53	1060	56	1005	59	943	63			
				1	1162	51	1118	53	1062	56	1014	58	958	62	892	NA	826	NA	780	NA			
PGF336100K****	3	100000	35 - 65	4	1652	44	1607	45	1574	46	1541	47	1500	48	1462	50	1426	51	1384	53			
				3	1529	48	1484	49	1440	50	1402	52	1364	53	1326	55	1284	57	1238	59			
				2	1278	57	1233	59	1191	61	1149	63	1108	NA	1060	NA	1005	NA	943	NA			
				1	1162	63	1118	65	1062	NA	1014	NA	958	NA	892	NA	826	NA	780	NA			
PGF342080K****	3.5	80000	35 - 65	4	1643	36	1609	37	1577	37	1541	38	1509	39	1476	40	1439	41	1402	42			
				3	1505	39	1467	40	1431	41	1398	42	1363	43	1324	45	1283	46	1234	48			
				2	1240	48	1189	50	1145	52	1104	54	1063	56	1010	59	952	62	891	NA			
				1	1138	52	1087	54	1041	57	989	60	940	63	865	NA	806	NA	752	NA			
PGF342100K****	3.5	100000	35 - 65	4	1643	44	1609	45	1577	46	1541	47	1509	48	1476	49	1439	51	1402	52			
				3	1505	48	1467	50	1431	51	1398	52	1363	53	1324	55	1283	57	1234	59			
				2	1240	59	1189	61	1145	63	1104	NA	1063	NA	1010	NA	952	NA	891	NA			
				1	1138	64	1087	NA	1041	NA	989	NA	940	NA	865	NA	806	NA	752	NA			
PGF348080K****	4	80000	35 - 65	4	1908	NA	1864	NA	1819	NA	1770	NA	1720	35	1678	35	1632	36	1586	37			
				3	1750	34	1696	35	1643	36	1592	37	1547	38	1497	40	1443	41	1400	42			
				2	1245	48	1170	51	1110	53	1034	57	972	61	924	64	875	NA	836	NA			
				1	1154	51	1084	55	1005	59	940	63	880	NA	832	NA	780	NA	713	NA			
PGF348120K****	4	120000	40 - 70	4	1908	47	1864	48	1819	49	1770	50	1720	52	1678	53	1632	54	1586	56			
				3	1750	51	1696	52	1643	54	1592	56	1547	57	1497	59	1443	62	1400	63			
				2	1245	NA	1170	NA	1110	NA	1034	NA	972	NA	924	NA	875	NA	836	NA			
				1	1154	NA	1084	NA	1005	NA	940	NA	880	NA	832	NA	780	NA	713	NA			
PGF354100K****	5	100000	30 - 60	4	2173	34	2113	35	2067	36	2032	36	2003	37	1962	38	1904	39	1822	41			
				3	2109	35	2052	36	2000	37	1952	38	1899	39	1847	40	1798	41	1750	42			
				2	1449	51	1372	54	1318	56	1258	59	1195	NA	1130	NA	1086	NA	1048	NA			
				1	1348	55	1274	58	1218	NA	1151	NA	1085	NA	1032	NA	989	NA	954	NA			
PGF354140K****	5	140000	35 - 65	4	2173	48	2113	49	2067	50	2032	51	2003	52	1962	53	1904	54	1822	57			
				3	2109	49	2052	51	2000	52	1952	53	1899	55	1847	56	1798	58	1750	59			
				2	1449	NA	1372	NA	1318	NA	1258	NA	1195	NA	1130	NA	1086	NA	1048	NA			
				1	1348	NA	1274	NA	1218	NA	1151	NA	1085	NA	1032	NA	989	NA	954	NA			

NA = Not Allowed for Heating Speed.

CIRCULATING AIR BLOWER SPEEDS

Model	Red	Black	Violet
PGF324	2	1	N/A
PGF330	3	2	N/A
PGF336	3	2	N/A
PGF342	4	3	N/A
PGF348	4	3	2
PGF354	4	3	2



Verify that the proper blower speeds for heating and cooling are selected on the blower motor by removing the blower access panel and inspecting the blower motor. The motor has 4 speeds numbered "1", "2", "3", and "4". The wires for the speed selection are as follows:

- Red** ➔ **Heating**
- Black** ➔ **High Stage Cooling**
- Violet** ➔ **Low Stage Cooling (4 & 5 ton only)**

Using the same speed for Heating and Cooling.

If the same speed is required for heating and high stage cooling the following procedure must be used:

1. Set Red wire on proper speed selection on blower motor.
2. Remove Black wire from "COOL" (2 - 3.5 Ton models) or "HI" (4 - 5 Ton Models) on Blower Interface Board. Tape end of Black lead using electrical tape.
3. Jumper the Red wire to both the "Heat" terminal and either the "COOL" (2 - 3.5 Ton models) or "HI" (4 - 5 Ton Models) terminal on the Blower Interface Board.

If the same speed is required for heating and low stage cooling (4 & 5 Ton models only), the following procedure must be used:

1. Set Red wire on proper speed selection on blower motor.
2. Remove Violet wire from "LO" on Blower Interface Board. Tape end of Violet lead using electrical tape.
3. Jumper the Red wire to both the "Heat" terminal and the "LO" terminal on the Blower Interface Board.

CONTINUOUS FAN OPERATION

Continuous fan speed operates at the cooling speed for 2 thru 3-1/2 ton models and at the low stage cooling speed for 4 and 5 ton models.

COOLING

1. Turn electric power **OFF**
2. Set thermostat Heat-Cool select to **COOL**.
3. Adjust thermostat setting to below room temperature.
4. Turn power **ON**, for approximately one minute, then **OFF**. During power application check the following:
 - a. Contactor - Contacts Closing
 - b. Compressor - **ON**
 - c. Condenser fan motor - **ON**
 - d. Circulating Air Blower - **ON** 0 second delay
5. Turn power **OFF**, check the following:
 - a. Contactor contacts opening.
 - b. Compressor - **OFF**
 - c. Condenser fan motor - **OFF**
 - d. Circulating blower - **OFF** after a 60 second delay for 2 thru 3-1/2 ton models and a 90 second delay for 4 and 5 ton models.

9. START-UP PROCEDURES

⚠️ WARNING

FIRE OR EXPLOSION HAZARD

Failure to follow this warning could result in property damage, personal injury, and/or death.

Do NOT attempt to light the burner with a match or flame of any kind.

CHECK BEFORE STARTING

1. Check that the blower motor speed terminal block is running the correct heating and cooling speeds.
2. Check to see that clean, properly sized air filters are installed.
3. Replace all service access panels.

Manifold Gas Pressure Adjustment

NOTE: Make adjustment to manifold pressure with burners operating.

⚠️ WARNING

FIRE OR EXPLOSION HAZARD.

Failure to follow this warning could result in personal injury and/or death.

Turn OFF gas at shut off before connecting U-tube manometer.

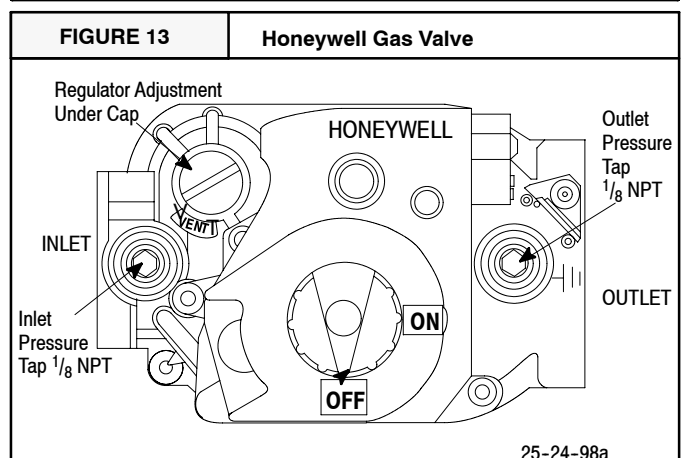

GAS PRESSURES

1. Do **NOT** allow gas supply pressure to fall below the listed minimums. Doing so will decrease input to furnace. Refer to **FIGURE 14** for gas supply pressures.
2. Gas input **MUST NOT** exceed rated input shown on rating plate.
3. Do **NOT** allow pressures to exceed the maximum limits as listed in **FIGURE 14**.

FIGURE 14	Gas Pressures	
	Natural Gas	LP Gas
Minimum Inlet	4.5" W.C. (1120 Pa)	11" W.C. (2740 Pa)
Recommended Inlet	7" W.C. (1740 Pa)	11" W.C. (2740 Pa)
Maximum Inlet	13" W.C. (3230 Pa)	13" W.C. (3230 Pa)
Manifold Pressure	3.5" W.C. (870 Pa)	10" W.C. (2490 Pa)

Manifold Pressures

Manifold pressures are covered in the startup procedure section. See Figure 15.

1. With gas **OFF**, Connect U-Tube manometer to tapped opening on gas valve. Use manometer with a 0 to 12 inches water column range.

FIGURE 15	Manifold Pressure Settings	
	Gas Type	Manifold Pressure
Natural	3.5 Inches Water Column (870 Pa)	
Propane	10 Inches Water Column (2490 Pa)	

2. Turn gas **ON** and remove adjustment screw cover on gas valve. Turn counterclockwise to decrease pressure and clockwise to increase.

NOTE: Adjustment screw cover **MUST** be placed on gas valve before reading manifold pressure and operating furnace.

! WARNING

FIRE AND/OR EXPLOSION HAZARD

Failure to follow this warning could result in property damage, personal injury and/or death.

Do NOT adjust manifold pressure more than ± 0.3 inches water column to obtain rated input.

3. Set pressure to value shown in **FIGURE 15**, ± 0.07 kPa (0.3 inches) water column. Pressure is also listed on furnace rating plate. In **NO** case should final manifold pressure vary more than ± 0.07 kPa (0.3 inches) water column.

Check the unit's operation as outlined in the following instructions. If any unusual sparking, odors or unusual noises are encountered, shut off electric power immediately. Recheck for wiring errors, or obstructions in or near blower motors.

1. Set thermostat Heat-Cool selector to **OFF**.
2. Set thermostat fan switch to **AUTO**.
3. Turn electric power **ON**. Nothing should start running.
4. Turn manual gas valve **ON**.
5. Turn gas control valve **ON**.
6. Set thermostat fan switch to **ON**.
7. Reset thermostat fan switch to **AUTO**.

HEATING START-UP PROCEDURE

1. Adjust thermostat setting above room temperature and set thermostat selector to **HEAT**. The combustion air blower should come **ON**.
2. The combustion air blower will run for 15 seconds to purge the combustion chamber.
3. After the 15 second purge, the combustion air blower will remain on. The sparker will turn on to ignite the gas. Make sure the gas valve is in the "ON" position. (Refer to Figure 14 and the instructions label located on Burner Access Panel of unit.
4. 30 seconds after the burners light, the circulating blower will begin to run.

NOTE: On a call for heat the sparker will remain energized for 7 seconds or until a flame is detected by the flame sensor. It may take several ignition attempts to purge the air out of the gas lines at initial start-up of the unit.

! WARNING

FIRE AND/OR EXPLOSION HAZARD

Failure to follow this warning could result in property damage, personal injury, and/or death.

Do NOT attempt to light the burner with a match or flame of any kind.

Temperature Rise Check

NOTE: Air temperature rise is the temperature difference between supply and return air. With a properly designed distribution system, the proper amount of temperature rise will normally be obtained when the unit is operating at rated input with the recommended blower speed.

1. The temperature rise must be within the specifications marked on the unit rating plate.

To check the temperature rise through the unit, place thermometers in the supply and return air ducts as close to the unit as possible.

Open **ALL** registers and duct dampers. Operate unit **AT LEAST** 15 minutes before taking readings.

If the correct amount of temperature rise is not obtained when operating on the recommended blower speed, it may be necessary to change the blower speed. A faster blower speed will decrease the temperature rise. A slower blower speed will increase the temperature rise.

NOTE: The blower speed **MUST** be set to give the correct air temperature rise through the furnace as marked on the rating plate. See **Figure 12** for more information.

2. After 15 minutes of operation check the limit control function by blocking the return air grille(s).
After several minutes the main burners and pilot should go **OFF**. The circulating air blower should continue to run.
Remove air restrictions. Pilot and main burners should relight after a cool down period of a few minutes.
3. Adjust the thermostat setting below room temperature.

Main burners and combustion air blower should go **OFF**.

The circulating air blower should continue to run for 60, 100, 140 or 180 seconds. This time is adjustable. See **FIGURE 16** for more information.

- Set thermostat Heat-Cool selector to **OFF**.

FAN CONTROL CHECK

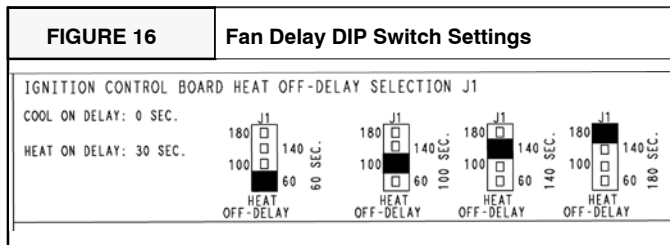

The Fan Control has adjustable settings for the circulating air blower to delay it "ON" and "OFF".

- The Fan Control has a fixed "ON" delay of 30 seconds, and a field adjustable "OFF" delay of 60, 100, 140 and 180 seconds. The "OFF" delay is factory set at 140 seconds.

Refer to **FIGURE 16** for proper DIP switch settings.

- Operate the furnace and ensure that the blower turns **ON** and **OFF** at the appropriate time to provide the desired comfort level.

10. OPERATION

⚠ WARNING
ELECTRICAL SHOCK HAZARD.
Failure to follow this warning could result in property damage, personal injury, and/or death.
Turn off electric power supply at disconnect switch or service panel before removing any access or service panel from unit.

COMBUSTION/INDOOR FAN CONTROL

All functions of the combustion and indoor blower are controlled by the fan control module.

On a call for heat:

The ignition control energizes the combustion blower. Once the combustion air proving switch closes, the ignition sequence begins. The ignition control will sense when the main operator of gas valve has been energized thereby firing the burners and starting the "delay on" timing sequence of the indoor blower.

NOTE: If the control senses that one of the safety limits has opened, the combustion and indoor fans will operate until the limit resets.

On a call for cooling:

The fan control board starts the indoor blower immediately. Once the thermostat is satisfied, the fan control will operate the blower for 30 additional seconds.

11. MAINTENANCE

MONTHLY MAINTENANCE AND INSPECTION CHECKS

Air Filters

⚠ CAUTION
REDUCED EQUIPMENT LIFE HAZARD
Failure to follow this cautions may result in damage to the unit being installed.
Do not operate the unit without a filter.

Inspect filters at least monthly and replace or clean as required. Washable filters may be cleaned by soaking in mild detergent and rinsing with cold water. Replace filters with the arrows on the side pointing in the direction of air flow. Dirty filters are the most common cause of inadequate heating or cooling performance, and of compressor failures.

HEATING SEASON CHECKS (MONTHLY)

Main Burner Flame

Flames should be stable and solid blue, (dust may cause orange tips or they may have wisps of yellow, but they **MUST** not have solid yellow tips). They should extend directly into the heat exchanger tubes and the turbulators should glow orange (after about five minutes of operation). Main burner flame should be inspected monthly.

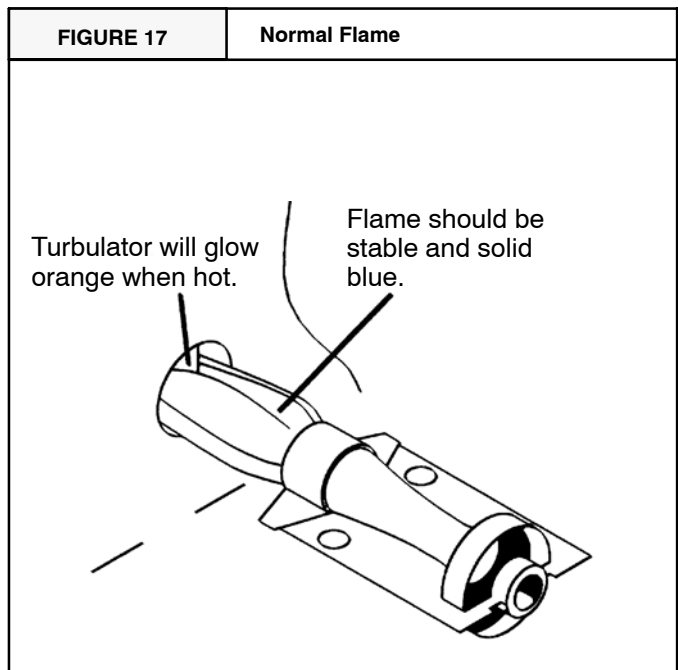

Using a light and mirror (as required) inspect the inside of the vent hood and the inlet air opening in the burner compartment. Look for soot and severe rust or corrosion and any obstructions due to leaves, spiderwebs, etc. Clean as required.

COOLING SEASON CHECKS (MONTHLY)

Condenser Coil

Keep the condenser inlet and outlet area clean and free of leaves, grass clippings or other debris. Grass should be kept short in front of the condenser inlet. Shrubbery **MUST** be trimmed back so it is no closer than 30 inches to unit.

Condensate Drain

Check for condensate drainage. Clean as required.

ANNUAL MAINTENANCE AND INSPECTION

⚠ WARNING

ELECTRICAL SHOCK HAZARD.

Failure to follow this warning could result in property damage, personal injury, and/or death.

Turn off electric power supply at disconnect switch or service panel before removing any access or service panel from unit.

The annual inspection should include cleaning as required to ensure efficient operation of the unit. To simplify access, remove all access panels and the top from the unit if possible .

Condenser Fan Motor

Note: The condenser fan motor is permanently lubricated. No further lubrication is required. Do not attempt to lubricate the condenser fan motor.

VENT ASSEMBLY

⚠ CAUTION

BURN HAZARD.

Failure to follow this caution may result in property damage or personal injury.

Flue cover may be hot! Allow adequate time for flue cover to cool.

Clean the surrounding area and the condenser and evaporator coils. Use caution to avoid damage to coil fins.

BLOWER MOTOR ACCESS

Refer to **Figure 19** for a view of blower motor and compartment.

1. Remove the blower access panel
2. Remove the three screws securing the blower motor housing. If unit has a support bracket, remove the two screws securing the bracket.
3. Remove the two red wires attached to the limit switch and remove the limit switch.

Motor removal and replacement

This method is required to replace or repair blower wheel, blower housing, or any unreachable components behind blower assembly.

1. Remove all screws around rim of unit top, (except screws which are inaccessible because of proximity to structure).

2. Raise unit top at corner of unit closest to blower at least 2" and place a sturdy brace at least 2" thick between top and unit corner. A 2X4 piece of wood is ideal for this.
3. Disconnect all wires from housing and slide housing out of unit. Reverse this process to reinstall.

Circulating Air Blower

Visually inspect the blower wheel for accumulations of dirt or lint. Clean the compartment and the blower wheel. If accumulation is excessive on blower wheel, or does not easily remove, it will be necessary to remove the blower assembly.

Note: The blower motor is permanently lubricated. No further lubrication is required. Do not attempt to lubricate the blower motor.

Burners / Heat Exchangers / Flue Gas Passages

To inspect the burners, heat exchanger and interior flue gas passages, use a light and small mirror on an extension handle.

Check the exterior of the heat exchanger and the interior flue gas passages for any evidence of deterioration due to corrosion, cracking or other causes. If signs of scaling or sooting exist, remove the burners and clean the heat exchanger, as required.

INSPECTION AND CLEANING OF BURNER ASSEMBLY/HEAT EXCHANGERS/FLUE GAS PASSAGES

For Qualified Service Technician Only

See **FIGURE 18** for identification of parts.

1. Disconnect electrical power to unit.
2. Turn **OFF** gas at manual shut off valve.
3. Remove burner access panel.
4. Remove the vent assembly flue pipe.
5. Disconnect gas pipe at union.
6. Disconnect wires from gas valve, note connections.
7. Remove screws that secure the flame shield and remove gas control valve, manifold and burners as an assembly.
8. Remove collector box, injector plate, and restrictor plate, including gaskets.
9. Hold the burner assembly vertically and lightly tap it against a wood block. Clean also with a stiff brush. Severe cases of lint clogging may require washing the burners in hot water.
10. Clean flue gas passages by using small brushes and a vacuum cleaner. It may be necessary to fabricate handle extensions for the brushes to reach the areas that require cleaning. Reinspect after cleaning and replace the heat exchanger if defective.
11. Reinstall parts and gaskets in reverse order. On direct spark models check the spark gap. $\frac{1}{8}$ inch is required between the sparker electrodes.
12. Turn gas on and check for leaks.
13. Install all access panels, turn power on and check for normal operation.

FIGURE 18

Component Locations

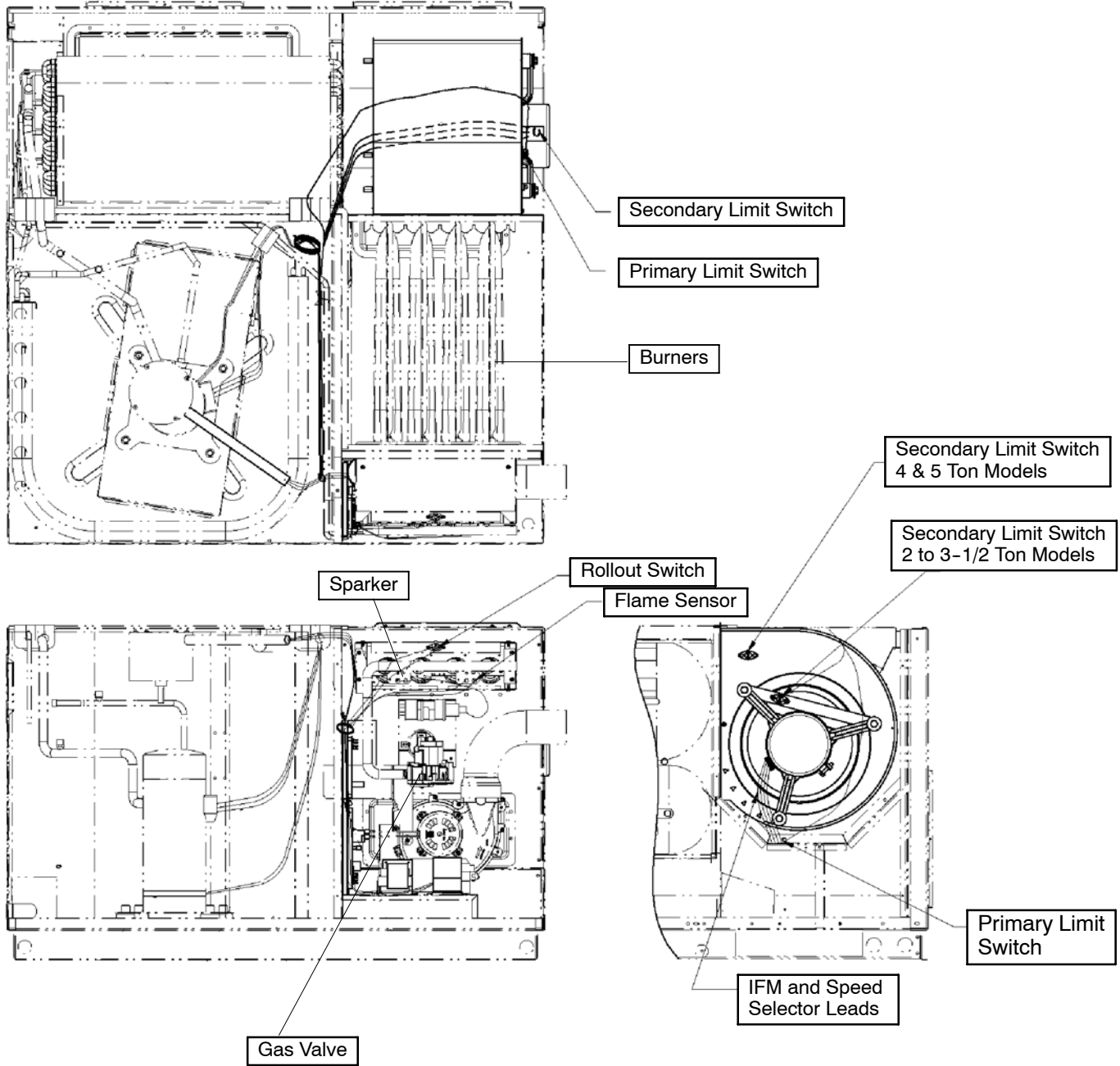

FIGURE 19

Rigging Instructions

1096286

RIGGING INSTRUCTIONS

FAILURE TO FOLLOW THESE INSTRUCTIONS CAN RESULT IN PROPERTY DAMAGE, BODILY INJURY OR DEATH.



- ALL PANELS MUST BE IN PLACE WHEN RIGGING AND LIFTING.
- HOOK RIGGING SHACKLES THROUGH HOLES IN BASE RAIL, AS SHOWN IN DETAIL -A.
- USE SPREADER BARS, WHEN RIGGING, TO PREVENT UNIT DAMAGE.
- BE SURE RIGGING AND SHACKLES ARE SUFFICIENT TO HANDLE WEIGHT LISTED BELOW.

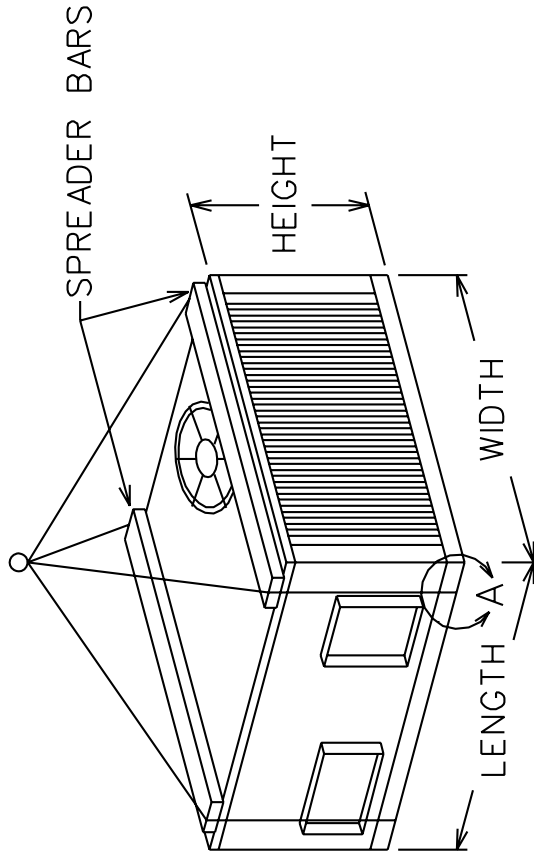

DETAIL - A

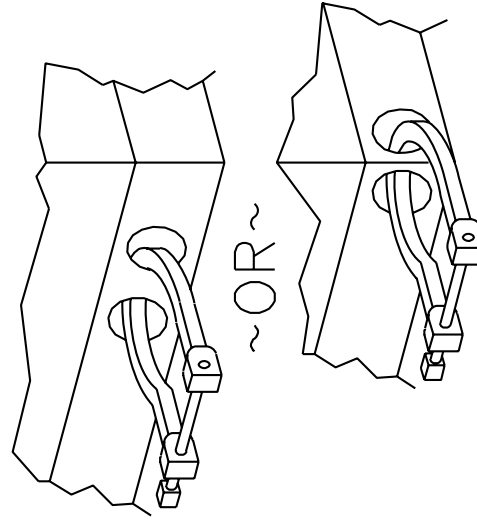

CABINET	MAX. LENGTH		MAX. WIDTH		MAX. HEIGHT		MAX. WEIGHT	
	IN	MM	IN	MM	IN	MM	LB	KG
SMALL	52.00	1219	48.00	1219	38.00	965	500	227
LARGE	73.00	1854	48.00	1219	38.00	965	900	409

2 to 3-1/2 Ton Wiring Diagram

CONNECTION WIRING DIAGRAM

DANGER: ELECTRICAL SHOCK HAZARD DISCONNECT POWER BEFORE SERVICING

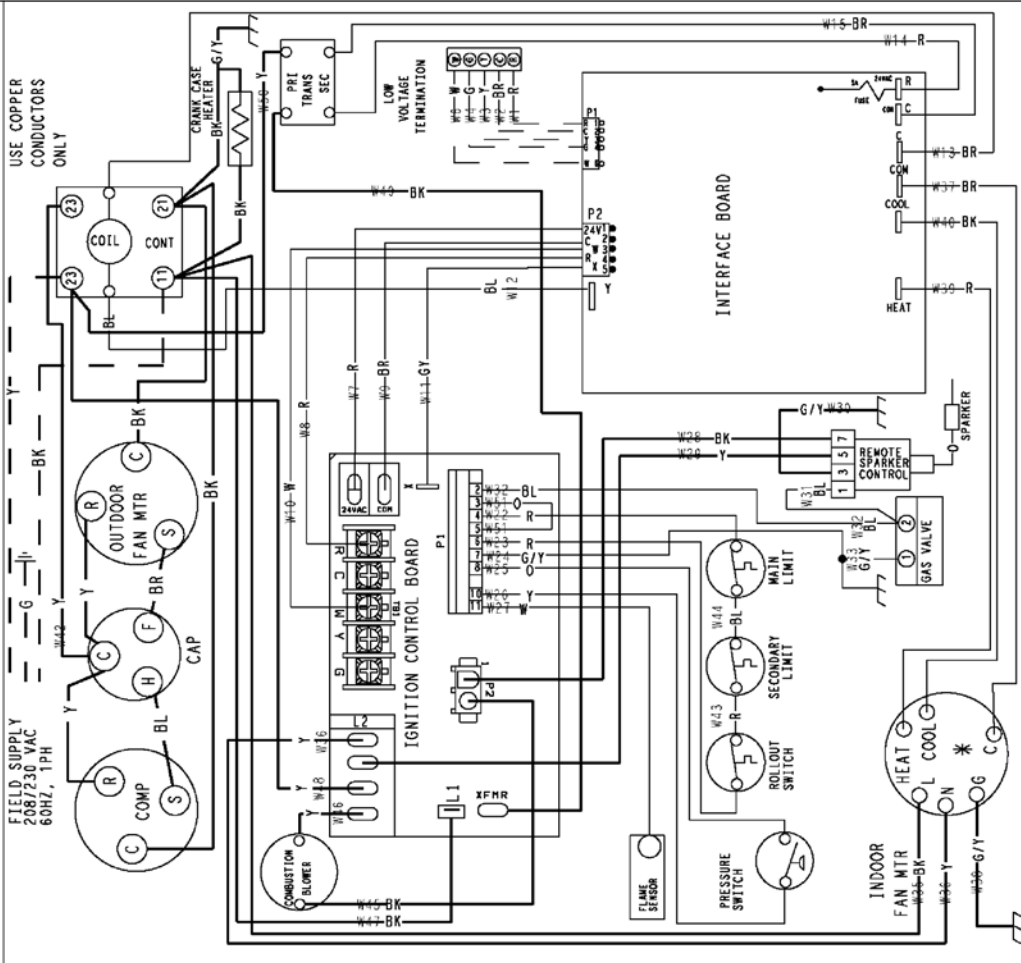

IF ANY OF THE ORIGINAL WIRE AS SUPPLIED WITH THE APPLIANCE MUST BE REPLACED, IT MUST BE REPLACED WITH TYPE AWN-105°C OR ITS EQUIVALENT.

SEE INSTALLATION INSTRUCTIONS FOR PROPER HEATING AND COOLING CONNECTIONS FOR YOUR UNIT. INDOOR FAN MOTOR PLUGS- "Do Not Disconnect Under Load"

—	LINE VOLTAGE FACTORY	BLACK	BK	GREEN	G	WHITE	W
- - -	LOW VOLTAGE FIELD	BLUE	BL	ORANGE	O	YELLOW	Y
— · —	LOW VOLTAGE FACTORY	BROWN	BR	RED	R		
— · — · —	LINE VOLTAGE FIELD	GRAY	GY	VIOLET	V		
— · — · — · —	INTERNAL CIRCUIT	PINK	P				
— · — · — · — · —	BOARD WIRING						

LADDER WIRING DIAGRAM

DANGER: ELECTRICAL SHOCK HAZARD DISCONNECT POWER BEFORE SERVICING

