

## Bronze Series

# HEAT RECOVERY VENTILATORS

### vänEE 90H #1601606

70 to 159 cfm (0.3 in. w.g.)

64 to 150 cfm (0.4 in. w.g.)



VB0023

### BRONZE SERIES: PERFECT FOR NEW RESIDENTIAL CONSTRUCTIONS

Affordability is a priority for the homebuilder who wants to offer a healthy indoor air quality. The Bronze Series is an entry level product, offering all the basic features for the new construction market, such as small size cabinet, integrated balancing damper and a no negative pressure defrost that ensures quick installation and trouble free operation. Best priced for builders & contractors who want simple, affordable and reliable products.

- **Good warranty** : 2 years on all unit parts, and a lifetime warranty on the heat recovery core.
  - **A minimum of vital parts per unit:** motor, damper motor and electronic circuit board.
  - **Microprocessors:** a proven technology known for its reliability which allows the elimination of numerous mechanical parts which are most likely to break down.
- Quiet ventilation is a priority for homeowners and builders. The Bronze Series HRVs provide the quietest operation compared to other units in its category (as much as 10 db quieter), thanks to:
- **The Silent operation system**, a unique design which allows the motor, located at the exhaust ports, to blow air into the house through an integrated silencer in the unit.
  - **The motor** is mounted in the center of the unit to avoid any vibration.

Available at:

### Controls and Options

- Built-in electronic circuit board ready to receive one of the following main controls:
  - Humidity Control #200694
  - Bronze Control #40250
- One of the following optional controls can be added:
  - 20-min. lighted push button #1806110
  - 60-min. mechanical timer #00910
- Complete line of registers and diffusers
- Electric duct heater
- Integrated furnace interlock relay

### Airflow During Air Exchange

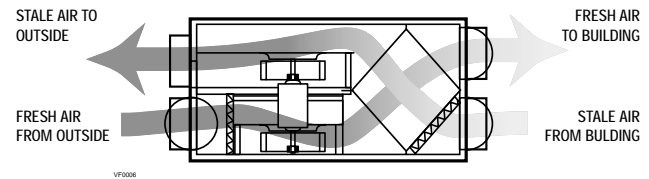

### No Negative Pressure Defrost

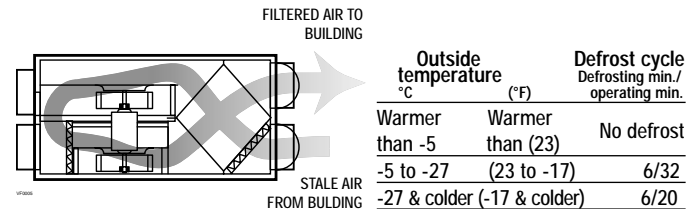

### Heat Recovery Core

Dimensions: 12" x 14" x 15-1/2" (30.5 cm x 35.6 x 39.4 cm)

Exchange surface: 102 ft<sup>2</sup> (9.5 m<sup>2</sup>)

Weight: 6.2 lbs (2.8 kg)

Material: Polypropylene (coroplast)

Type: Crossflow core

Warranty: Lifetime

### Requirements and Standards

- Complies with the CSA C22.2 # 113 Standard applicable to ventilators.
- Complies with CSA F326 requirements regulating the installation of Heat Recovery Ventilators.
- HVI certified
- Technical data was obtained from published results of tests relating to CSA C439 Standards.

# Dimensions and Service Clearances of vanEE 90H

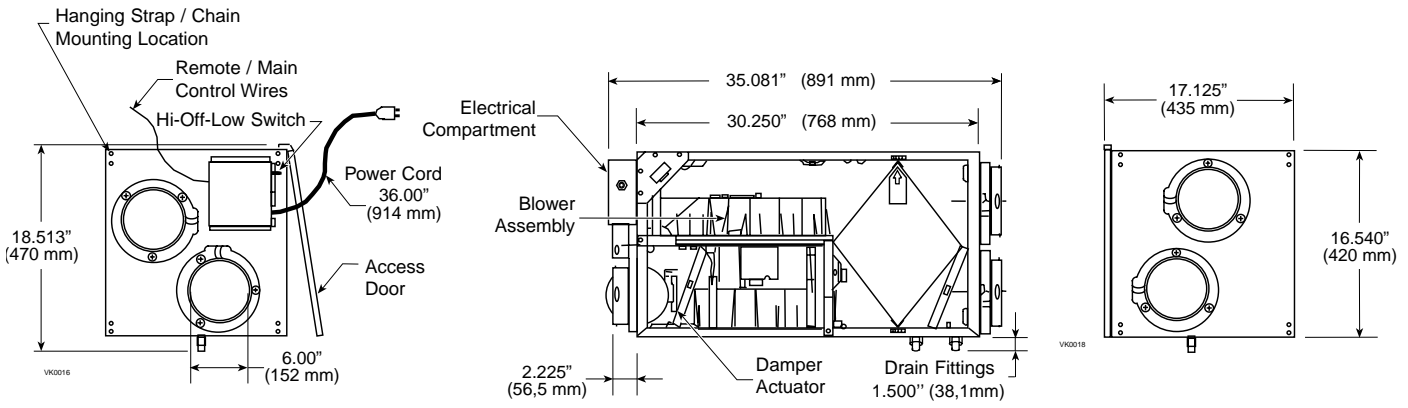

## Ventilation Performance

EXT. STATIC PRESSURE Pa	in. w.g.	NET SUPPLY AIR FLOW			GROSS AIR FLOW					
		l/s	cfm	m <sup>3</sup> /h	l/s	cfm	m <sup>3</sup> /h	l/s	cfm	m <sup>3</sup> /h
25	.1	83	175	297	83	176	299	82	175	297
50	.2	79	168	285	80	169	287	78	165	280
75	.3	75	159	270	75	159	270	75	158	268
100	.4	71	150	255	71	151	257	69	146	248
125	.5	64	136	231	64	136	231	60	127	216
150	.6	60	126	214	60	127	216	48	103	175
175	.7	53	113	192	53	113	192	38	80	136
200	.8	43	91	155	43	91	155	21	45	76

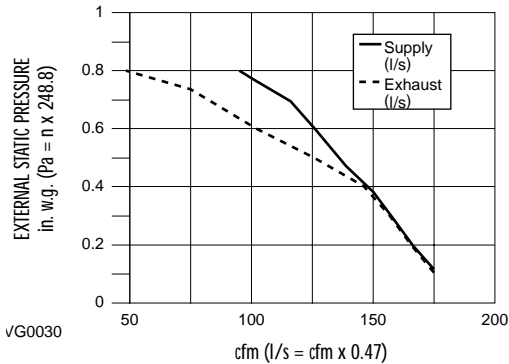

## Energy Performance

SUPPLY TEMPERATURE		NET AIR FLOW			POWER CONSUMED WATTS	SENSIBLE RECOVERY EFFICIENCY	APPARENT SENSIBLE EFFECTIVENESS	LATENT RECOVERY/MOISTURE TRANSFER
C°	F°	l/s	cfm	m <sup>3</sup> /h				
<b>HEATING</b>								
0	+32	31	66	112	85	69	81	-0.01
0	+32	56	119	202	124	60	70	-0.01
0	+32	---	---	---	---	---	---	---
-25	-13	37	78	133	114	62	80	0.08
-25	-13	---	---	---	---	---	---	---
<b>COOLING</b>								
+35	+95	---	---	---	---	TOTAL RECOVERY EFFICIENCY		
+35	+95	---	---	---	---	Not tested		

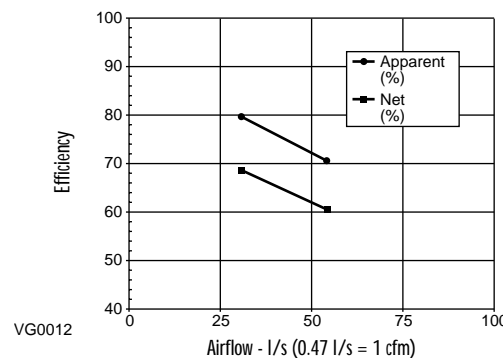

## Specifications and Ratings

- Model: vanEE 90H
- Part Number #1601606
- Total Assembled Weight: 65 lbs (30 Kg)
- Supply Air Duct Connections: 6" diameter
- Exhaust Air Duct Connections: 6" diameter
- Drains: 1/2" Fittings
- Filters: 20 ppi washable reticulated foam  
15.44" x 7.375" x 0.75" (39.2 x 18.7 x 1.9 cm)  
15.44" x 8.5" x 0.75" (39.2 x 21.6 x 1.9 cm)
- Cabinet: 20 ga. pre-painted steel
- Insulation: 1.00" aluminum foil faced fiberglass
- Mounting: Chain and hardware provided to suspend unit
- Supply & Exhaust Blower Motors:
  - Voltage: 120 volts
  - Hz: 60 Hz
  - HP: 1/18
  - RPM: 1660/1300/1050
  - Bearings: Sleeve bearings
  - Type: PSC
- Fan Speed Control: -Low, increased low speed & high -Two speeds available to user. -Low or increased low speed is selected during the installation.
- Heat Recovery Core:
  - Heat Exchange Surface Area: 102 ft<sup>2</sup> (9.5 m<sup>2</sup>)
  - Type/Material: Crossflow - Polypropylene
- Unit Electrical Characteristics:
  - Voltage: 120 volts
  - Power: 150 watts
  - Current: 1.3 amps



NOTE: All specifications are subjected to change without notice.

Submitted by:		Date:	Project:
Qty:	Model #:	Remarks:	Location:
			Architect:
			Engineer:
			Contractor:



550 Lemire B lvd., Drummondville, QC, Canada J2C W97 - Tel.: 1-800-567-3855 Fax: 1-800-567-1715

