

**INSTALLER: THESE INSTRUCTIONS MUST BE CONVEYED TO AND REMAIN WITH THE HOMEOWNER.**



# INSTALLATION AND OPERATION INSTRUCTIONS

CERTIFIED UNDER AMERICAN AND CANADIAN NATIONAL STANDARDS: ANSI Z21.88, CSA 2.33 FOR VENTED GAS FIREPLACE HEATERS.

## BC36DFN

NATURAL GAS

## BC36DFP

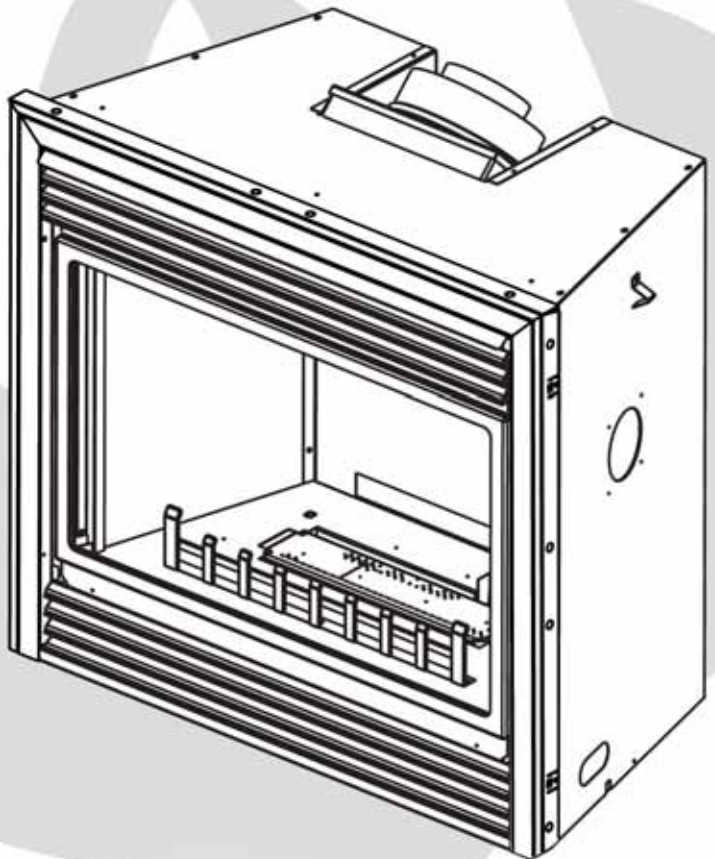
PROPANE

CERTIFIED FOR CANADA AND UNITED STATES USING ANSI/CSA METHODS.

### SAFETY INFORMATION

**WARNING:** If the information in these instructions are not followed exactly, a fire or explosion may result causing property damage, personal injury or loss of life.

- Do not store or use gasoline or other flammable vapors and liquids in the vicinity of this or any other appliance.
- **WHAT TO DO IF YOU SMELL GAS:**
  - Do not try to light any appliance.
  - Do not touch any electrical switch; do not use any phone in your building.
  - Immediately call your gas supplier from a neighbour's phone. Follow the gas supplier's instructions.
  - If you cannot reach your gas supplier, call the fire department.
- Installation and service must be performed by a qualified installer, service agency or the supplier.



APPLY SERIAL NUMBER LABEL FROM CARTON



Serial No. X X X X X 0 0 0 0 0 0  
MODEL NO

Wolf Steel Ltd., 24 Napoleon Rd., Barrie, ON L4M 4Y8 Canada • (705)721-1212 • fax(705)722-6031  
www.continentalfireplaces.com • ask@continentalfire.on.ca

# TABLE of CONTENTS

## PG 2-4 INTRODUCTION

Warnings and Safety Precautions  
Warranty  
General Instructions  
General Information  
Care of Glass & Plated Parts

## 5 - 12 VENTING

Venting Lengths  
Minimum Air Terminal Location Clearances  
Typical Minimum and Maximum Vent Lengths  
Special Vent Installations  
Venting Specifications  
Horizontal Termination  
Vertical Termination

## 13 - 17 INSTALLATION

Wall and Ceiling Protection  
Horizontal Installation  
Adjustable Firestop  
Vertical Installation  
Using Flexible Vent Components  
Fireplace Vent Connection  
Restricting Vertical Vents  
Gas Installation  
Mobile Home Installation  
Framing  
Nailing Tab Installation  
Minimum Mantle and Enclosure Clearances

## 18-19 FINISHING

Door Removal & Installation  
Louvre Installation  
Log Placement / Glowing Embers  
Charcoal Embers  
Charcoal Lumps  
Logo Placement

## 20 OPTIONAL BLOWER INSTALLATION

## 21 OPTIONAL FAN INSTALLATION / GD36 THERMOSTATIC SENSOR CONTROL

## 22 OPERATION / MAINTENANCE

Operating Instructions  
Maintenance

## 23 ADJUSTMENTS

Pilot Burner Adjustment  
Venturi Adjustment

## 24-25 REPLACEMENTS

Ordering Replacement Parts  
Replacement Parts  
Vent Kits  
Terminal Kits  
Accessories

## 26-27 TROUBLE SHOOTING GUIDE

## 28 HISTORY

## PLEASE RETAIN THIS MANUAL FOR FUTURE REFERENCE

### WARNING

- Do not burn wood or other materials in this fireplace.
- Adults and especially children should be alerted to the hazards of high surface temperatures and should stay away to avoid burns or clothing ignition. Keep young children and animals away when the fireplace is hot.
- Due to high temperatures, the fireplace should be located out of traffic and away from furniture and draperies.
- Clothing or other flammable material should not be placed on or near the fireplace.
- Any safety screen or guard removed for servicing must be replaced prior to operating the fireplace.
- It is imperative that the control compartments, burners and circulating blower and its passageway in the fireplace and venting system are kept clean. The fireplace and its venting system should be inspected before use and at least annually by a qualified service person. More frequent cleaning may be required due to excessive lint from carpeting, bedding material, etc. The fireplace area must be kept clear and free from combustible materials, gasoline and other flammable vapours and liquids.
- Under no circumstances should this fireplace be modified.
- This fireplace must not be connected to a chimney flue pipe serving a separate solid fuel burning appliance.
- Do not use this fireplace if any part has been under water. Immediately call a qualified service technician to inspect the fireplace and to replace any part of the control system and any gas control which has been under water.
- Do not operate the fireplace with the glass door removed, cracked or broken. Replacement of the glass should be done by a licensed or qualified service person. Use only with a glass door certified with the fireplace.
- Do not strike or slam shut the fireplace glass door.
- This fireplace uses and requires a fast acting thermocouple. Replace only with a fast acting thermocouple supplied by Wolf Steel Ltd.

**CONTINENTAL® gas fireplaces are manufactured under the strict Standard of the world recognized ISO 9001 : 2000 Quality Assurance Certificate.**

**CONTINENTAL® products are designed with superior components and materials, assembled by trained craftsmen who take great pride in their work. The burner and valve assembly are leak and test-fired at a quality test station. Once assembled the complete fireplace is thoroughly inspected by a qualified technician before packaging to ensure that you, the customer, receives the quality product that you expect from CONTINENTAL®.**

### **CONTINENTAL® GAS FIREPLACE PRESIDENT'S LIFETIME LIMITED WARRANTY**

*The following materials and workmanship in your new CONTINENTAL® gas fireplace are warranted against defects for as long as you own the fireplace. This covers: combustion chamber, heat exchanger, stainless steel burner, phazer™ logs and embers, ceramic glass (thermal breakage only), gold plated parts against tarnishing, porcelainized enamelled components and aluminum extrusion trims.*

*Electrical (110V and millivolt) components and wearable parts such as blowers, gas valves, thermal switch, switches, wiring, remote controls, ignitor, gasketing, and pilot assembly are covered and CONTINENTAL® will provide replacement parts free of charge during the first year of the limited warranty.*

*Labour related to warranty repair is covered free of charge during the first year. Repair work, however, requires the prior approval of an authorized company official. Labour costs to the account of CONTINENTAL® are based on a predetermined rate schedule and any repair work must be done through an authorized CONTINENTAL® dealer.*

### **CONDITIONS AND LIMITATIONS**

CONTINENTAL® warrants its products against manufacturing defects to the original purchaser only -- i.e., the individual or legal entity (registered customer) whose name appears on the warranty registration card filed with CONTINENTAL® -- provided that the purchase was made through an authorized CONTINENTAL® dealer and is subject to the following conditions and limitations:

This factory warranty is nontransferable and may not be extended whatsoever by any of our representatives.

The gas fireplace must be installed by a licenced, authorized service technician or contractor. Installation must be done in accordance with the installation instructions included with the product and all local and national building and fire codes.

This limited warranty does not cover damages caused by misuse, lack of maintenance, accident, alterations, abuse or neglect and parts installed from other manufacturers will nullify this warranty.

This limited warranty further does not cover any scratches, dents, corrosion or discolouring caused by excessive heat, abrasive and chemical cleaners nor chipping on porcelain enamel parts, mechanical breakage of PHAZER™ logs and embers, nor any venting components used in the installation of the fireplace.

CONTINENTAL® warrants its stainless steel burners against defects in workmanship and material for life, subject to the following conditions: During the first 10 years CONTINENTAL® will replace or repair the defective parts at our option free of charge. From 10 years to life, CONTINENTAL® will provide replacement burners at 50% of the current retail price.

In the first year only, this warranty extends to the repair or replacement of warranted parts which are defective in material or workmanship provided that the product has been operated in accordance with the operation instructions and under normal conditions.

After the first year, with respect to this President's Limited Lifetime Warranty, CONTINENTAL® may, at its discretion, fully discharge all obligations with respect to this warranty by refunding to the original warranted purchaser the wholesale price of any warranted but defective part(s).

After the first year, CONTINENTAL® will not be responsible for installation, labour or any other costs or expenses related to the reinstallation of a warranted part, and such expenses are not covered by this warranty.

Notwithstanding any provisions contained in this President's Limited Lifetime Warranty, CONTINENTAL'S responsibility under this warranty is defined as above and it shall not in any event extend to any incidental, consequential or indirect damages.

This warranty defines the obligations and liability of CONTINENTAL® with respect to the CONTINENTAL® gas fireplace and any other warranties expressed or implied with respect to this product, its components or accessories are excluded.

CONTINENTAL® neither assumes, nor authorizes any third party to assume, on its behalf, any other liabilities with respect to the sale of this product. CONTINENTAL® will not be responsible for: over-firing, downdrafts, spillage caused by environmental conditions such as rooftops, buildings, nearby trees, hills, mountains, inadequate vents or ventilation, excessive venting configurations, insufficient makeup air, or negative air pressures which may or may not be caused by mechanical systems such as exhaust fans, furnaces, clothes dryers, etc.

Any damages to fireplace, combustion chamber, heat exchanger, brass trim or other component due to water, weather damage, long periods of dampness, condensation, damaging chemicals or cleaners will not be the responsibility of CONTINENTAL®.

The bill of sale or copy will be required together with a serial number and a model number when making any warranty claims from your authorized dealer. The warranty registration card must be returned within fourteen days to register the warranty.

CONTINENTAL® reserves the right to have its representative inspect any product or part thereof prior to honouring any warranty claim.

## GENERAL INSTRUCTIONS

*THIS GAS FIREPLACE SHOULD BE INSTALLED AND SERVICED BY A QUALIFIED INSTALLER* to conform with local codes. In absence of local codes, install the **B36DF** to the current National Fuel Gas Code, ANSI Z223.1, or the current CAN/CGA B149, Installation Codes.

Installation practices vary from region to region and it is important to know the specifics that apply to your area,

for example: in Massachusetts State:

- The fireplace damper must be removed or welded in the open position prior to installation of a fireplace insert or gas log.
- A carbon monoxide detector is required in all rooms containing gas fired appliances
- The appliance off valve must be a "T" handle gas cock.
- The flexible connector must not be longer than 36 inches.
- The appliance is not approved for installation in a bedroom or bathroom unless the unit is a direct vent sealed combustion product.
- **WARNING:** This product must be installed by a licensed plumber or gas fitter when installed within the commonwealth of Massachusetts.

Mobile home installation must conform with local codes or in the absence of local codes, install to the current standard for gas equipped mobile housing CAN/CSA ZA240 MH Series in Canada or the Manufactured Home Construction and Safety Standard, Title 24 CFR, Part 3280, or the Fire Safety Criteria for Manufactured Home Installations, Sites and Communities Standard ANSI/NFPA 501A in the United States.

The fireplace and its individual shutoff valve must be disconnected from the gas supply piping system during any pressure testing of that system at test pressures in excess of 1/2 psig (3.5 kPa). The fireplace must be isolated from the gas supply piping system by closing its individual manual shutoff valve during any pressure testing of the gas supply piping system at test pressures equal to or less than 1/2 psig (3.5 kPa).

When the fireplace is installed directly on carpeting, vinyl tile or other combustible material other than wood flooring, the fireplace shall be installed on a metal or wood panel extending the full width and depth.

If the optional fan or blower is installed, the junction box must be electrically connected and grounded in accordance with local codes. In the absence of local codes, use the current CSA C22.1 CANADIAN ELECTRICAL CODE in Canada or the ANSI/NFPA 70 NATIONAL ELECTRICAL CODE in the United States.

## GENERAL INFORMATION

*FOR YOUR SATISFACTION, THIS FIREPLACE HAS BEEN TEST-FIRED TO ASSURE ITS OPERATION AND QUALITY!* Maximum input is 23,000 BTU/hr for natural gas and propane. When the fireplace is installed at elevations above 4,500ft, and in the absence of specific recommendations from the local authority having jurisdiction, the certified high altitude input rating shall be reduced at the rate of 4% for each additional 1,000ft.

Maximum output for natural gas and propane is 15,200 BTU/hr at an efficiency of 66% with the fan on. The maximum A.F.U.E. (annual fuel utilization efficiency) rating is 62% for natural gas and propane.

Minimum inlet gas supply pressure is 4.5 inches water column for natural gas and 11 inches water column for propane. Maximum inlet gas pressure is 7 inches water column for natural gas and 13 inches water column for propane. Manifold pressure under flow conditions is 3.5 inches water column for natural gas and 10 inches water column for propane.

This fireplace is approved for bathroom, bedroom and bed-sitting room installations and is suitable for mobile home installation.

***No external electricity (110 volts or 24 volts) is required for the gas system operation.***

*Expansion / contraction noises during heating up and cooling down cycles are normal and are to be expected.*

## CARE OF GLASS, AND PLATED PARTS

Do not use abrasive cleaners to clean plated parts. Buff lightly with a clean dry cloth. The B36DF is factory equipped with tempered glass. The glass thickness is 3/16". Use only replacement glass available from your Continental® dealer. **DO NOT SUBSTITUTE MATERIALS.** Clean the glass after the first 10 hours of operation with a recommended gas fireplace glass cleaner. Thereafter clean as required. **DO NOT CLEAN GLASS WHEN HOT!** If the glass is not kept clean permanent discoloration and / or blemishes may result.

***Use only accessories designed for and listed with your specific fireplace.***

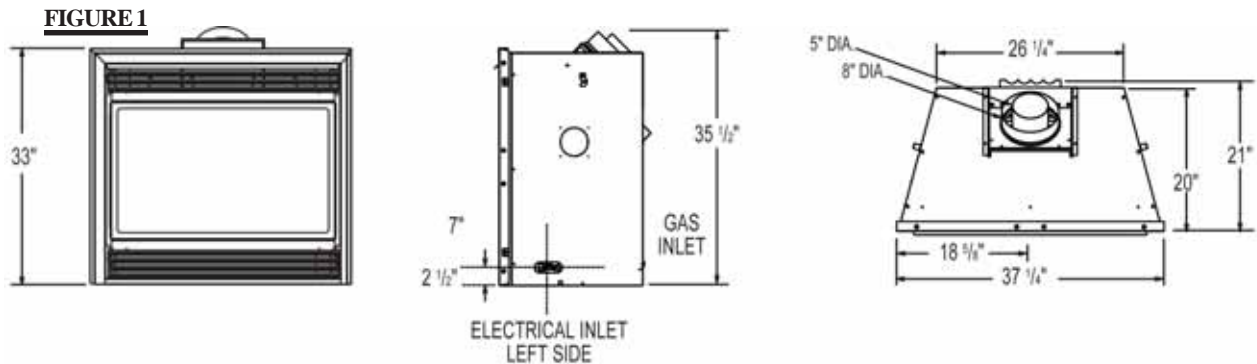
***Provide adequate ventilation air. Provide adequate accessibility clearance for servicing and operating the fireplace. Never obstruct the front opening of the fireplace.***

***For safe and proper operation of the fireplace follow the venting instruction exactly.***

***In order to avoid the possibility of exposed insulation or vapour barrier coming in contact with the fireplace body, it is recommended that the walls of the fireplace enclosure be 'finished', (i.e. drywall/sheetrock) as would any other outside wall of the home. This will ensure that clearance to combustibles is maintained within the cavity.***



We suggest that our gas hearth products be installed and serviced by professionals who are certified in the U.S. by the National Fireplace Institute® (NFI) as NFI Gas Specialists.



## VENTING

**For safe and proper operation of the fireplace follow the venting instruction exactly.**

**Deviation from the minimum vertical vent length can create difficulty in burner start-up and/or carboning.**

**Provide a means for visually checking the vent connection to the fireplace after the fireplace is installed.**

**Vent lengths that pass through unheated spaces (attics, garages, crawl spaces) should be insulated with the insulation wrapped in a protective sleeve to minimize condensation.**

### VENTING LENGTHS

Use only Wolf Steel, Simpson Dura-Vent, Selkirk Direct Temp or American Metal Amerivent venting components.

For Simpson Dura-Vent, Selkirk Direct Temp and American Metal Amerivent, follow the installation procedure provided with the venting components.

All outer pipe joints of these venting systems must be sealed using Red RTV High Temperature Sealant.

Wolf Steel, Simpson Dura-Vent, Selkirk Direct Temp and American Metal Amerivent venting systems must not be combined.

A starter adaptor must be used and may be purchased from the corresponding supplier:

PART	5"/8"	SUPPLIER
Duravent	W175-0170	Wolf Steel
Amerivent	5DSC-N	American Metal
Direct Temp	5DT-AAN	Selkirk

For vent systems that provide seals on the inner exhaust flue, only the outer air intake joints must be sealed using a red high temperature silicone (RTV). This same sealant maybe used on both the inner exhaust and outer intake vent pipe joints of all other approved vent systems except for the exhaust vent pipe connection to the fireplace flue collar which must be sealed using the black high temperature sealant Mill Pac.

When using Wolf Steel venting components, use only approved Wolf Steel rigid / flexible components with the following termination kits: WALL TERMINAL KIT **GD422**, or 1/12 TO 7/12 PITCH ROOF TERMINAL KIT **GD410**, 8/12 TO 12/12 ROOF TERMINAL KIT **GD411**, FLAT ROOF TERMINAL KIT **GD412** or PERISCOPE KIT **GD401** (for wall penetration below grade). With flexible venting, in conjunction with the various terminations, use either the 5 foot vent kit **GD420** or the 10 foot vent kit **GD430**.

These vent kits allow for either horizontal or vertical venting of the fireplace. **FIGURES 3 & 5**. The maximum allowable horizontal run is 20 feet.

The maximum allowable vertical vent length is 40 feet. The maximum number of 5" vent connections is two horizontally or three vertically (excluding the fireplace and the air terminal connections) when using aluminum flexible venting.

*For optimum flame appearance and fireplace performance, keep the vent length and number of elbows to a minimum.*

*The air terminal must remain unobstructed at all times. Examine the air terminal at least once a year to verify that it is unobstructed and undamaged.*

*Purge all gas lines with the glass door of the fireplace removed. Assure that a continuous gas flow is at the burner before re-installing the door.*

*Under extreme vent configurations, allow several minutes (5-15) for the flame to stabilize after ignition.*

*Eight (8") inches is the minimum bend radius allowed for the 8" diameter flexible liner.*

*For optimum performance it is recommended that all horizontal runs have a 1 inch rise per foot when using Continental® flexible vent components.*

*A terminal shall not terminate directly above a sidewalk or paved driveway which is located between two single family dwellings and serves both dwellings. Local codes or regulations may require different clearances.*

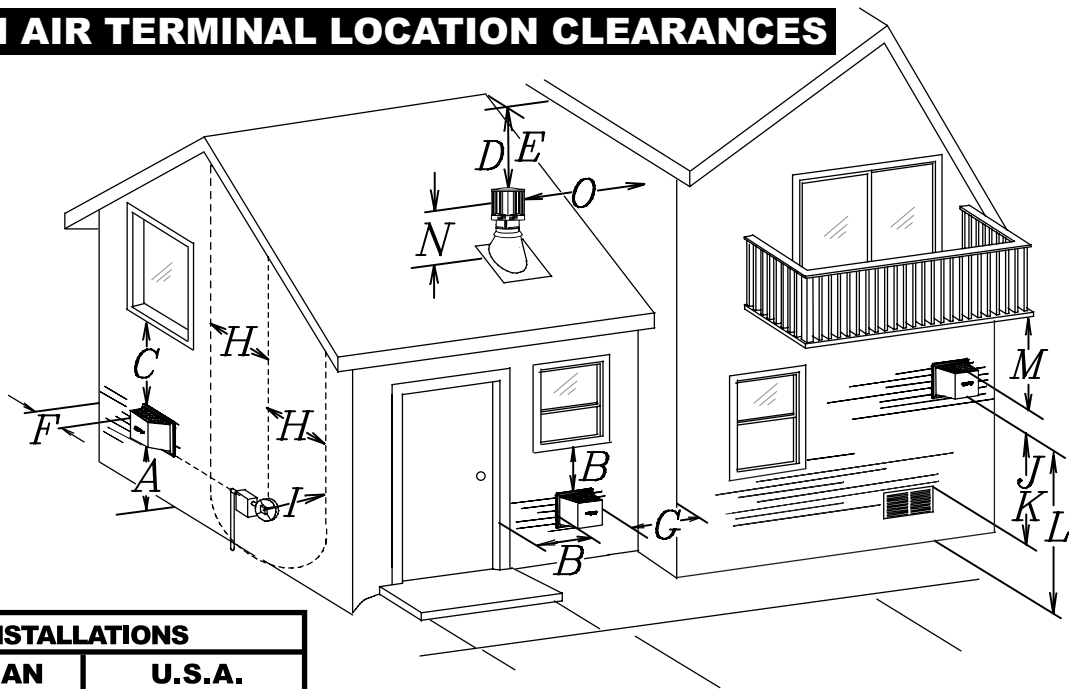
**Objects placed in front of the fireplace must be kept a minimum of 48" away from the front face of the unit.**

<b>Minimum clearance to combustible construction from fireplace and vent surfaces:</b>	
sides, back and bottom	0" (to stand off)
top (framing)	7 1/2"
finishing	0"
recessed depth	21"
sides and bottom of the vent pipe	1"
top of vent	2"

*Horizontal runs may have a 0 inch rise per foot in all cases using Wolf Steel, Simpson Dura-Vent, Selkirk Direct Temp, or American Metal Amerivent rigid vent components and Wolf Steel flexible vent components. For optimum performance, it is recommended that horizontal runs have a minimum 1/4 inch rise per foot when using Simpson Dura-Vent, Selkirk Direct Temp, American Metal Amerivent or Wolf Steel rigid vent components and a minimum 1 inch rise per foot when using Wolf Steel flexible vent components. For safe and proper operation of the fireplace, follow the venting instructions exactly.*

## MINIMUM AIR TERMINAL LOCATION CLEARANCES

FIGURE 2



INSTALLATIONS			
	CANADIAN	U.S.A.	
<b>A</b>	12 INCHES	12 INCHES	Clearance above grade, veranda porch, deck or balcony.
<b>B</b>	12 INCHES	9 INCHES	Clearance to windows or doors that open.
<b>C</b>	12 INCHES*	12 INCHES*	Clearance to permanently closed windows.
<b>D</b>	18 INCHES**	18 INCHES**	Vertical clearance to ventilated soffit located above the terminal within a horizontal distance of 2 feet from the centerline of the terminal.
<b>E</b>	12 INCHES**	12 INCHES**	Clearance to unventilated soffit.
<b>F</b>	0 INCHES	0 INCHES	Clearance to an outside corner wall.
<b>G</b>	0 INCHES***	0 INCHES***	Clearance to an inside <i>non</i> -combustible corner wall or protruding <i>non</i> -combustible obstructions (chimney, etc.).
	2 INCHES***	2 INCHES***	Clearance to an inside combustible corner wall or protruding combustible obstructions ( vent chase, etc.).
<b>H</b>	3 FEET	3 FEET****	Clearance to each side of the centerline extended above the meter / regulator assembly to a maximum vertical distance of 15ft.
<b>I</b>	3 FEET	3 FEET****	Clearance to a service regulator vent outlet.
<b>J</b>	12 INCHES	9 INCHES	Clearance to a non-mechanical air supply inlet to the building or a combustion air inlet to any other appliance.
<b>K</b>	6 FEET	3 FEET†	Clearance to a mechanical air supply inlet.
<b>L</b>	7 FEET‡	7 FEET****	Clearance above a paved sidewalk or paved driveway located on public property unless fitted with a heat shield kit GD-301.
<b>M</b>	12 INCHES††	12 INCHES****	Clearance under a veranda, porch, deck or balcony.
<b>N</b>	16 INCHES	16 INCHES	Clearance above the roof.
<b>O</b>	2 FEET†*	2 FEET†*	Clearance from an adjacent wall including neighbouring buildings.

\* Recommended to prevent condensation on windows and thermal breakage

\*\* It is recommended to use a heat shield and to maximize the distance to vinyl clad soffits.

\*\*\* The periscope GD-201 requires a minimum 18 inches clearance from an inside corner.

\*\*\*\* This is a recommended distance. For additional requirements check local codes.

† 3 feet above if within 10 feet horizontally.

‡ A vent shall not terminate directly above a sidewalk or paved driveway that is located between two single family dwellings and serves both dwellings.

†† Permitted only if the veranda, porch, or deck is fully open on a minimum of two sides beneath the floor.

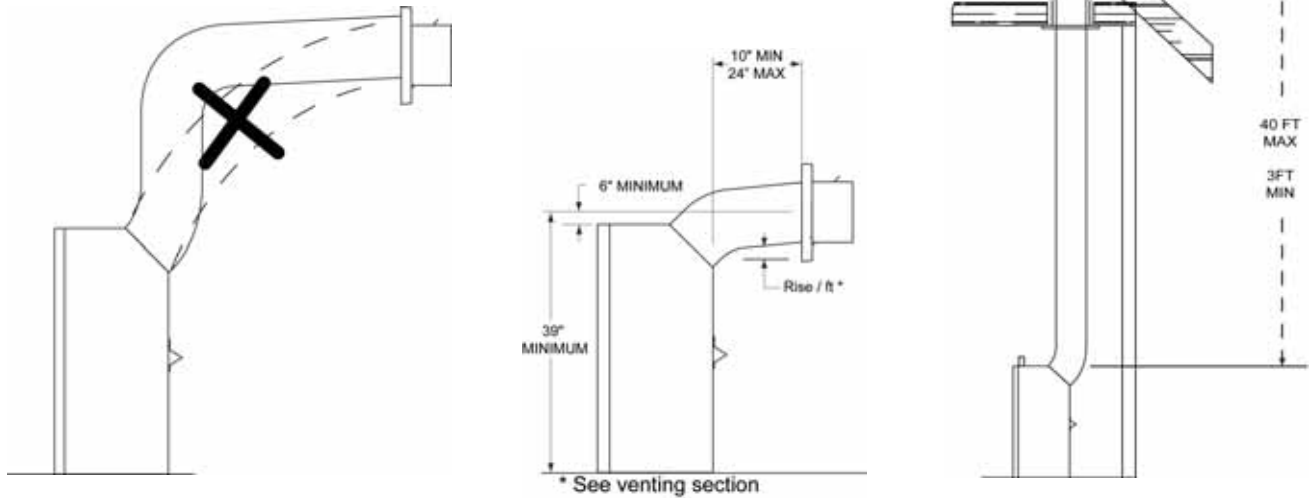
†\* Recommended to prevent recirculation of exhaust products. For additional requirements check local codes.

## TYPICAL MINIMUM AND MAXIMUM VENT LENGTHS

### NOTE:

When terminating vertically, the restrictor plate W500-0205 must be installed. Refer to Restricting Vertical Vents.

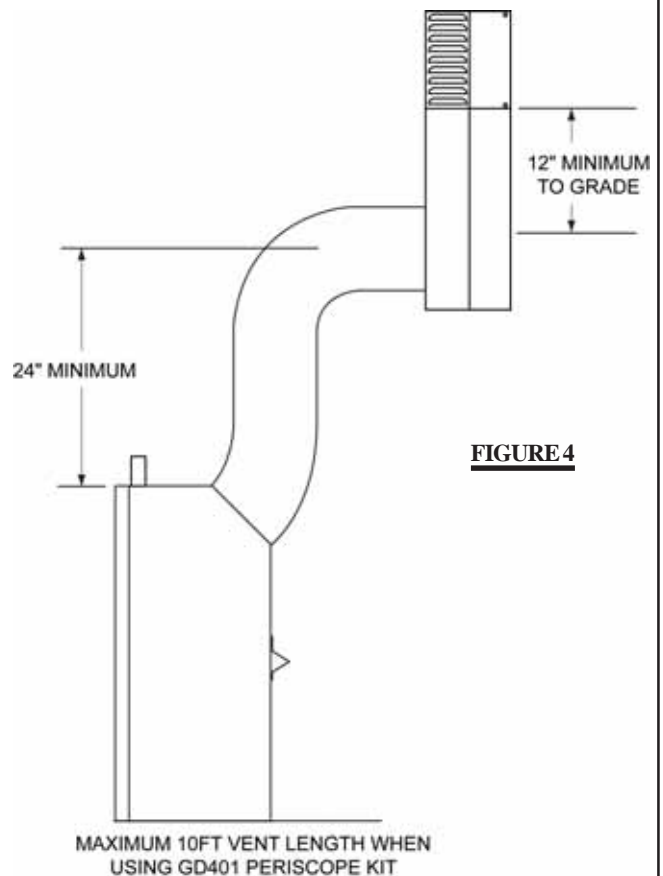
FIGURES 3a-c

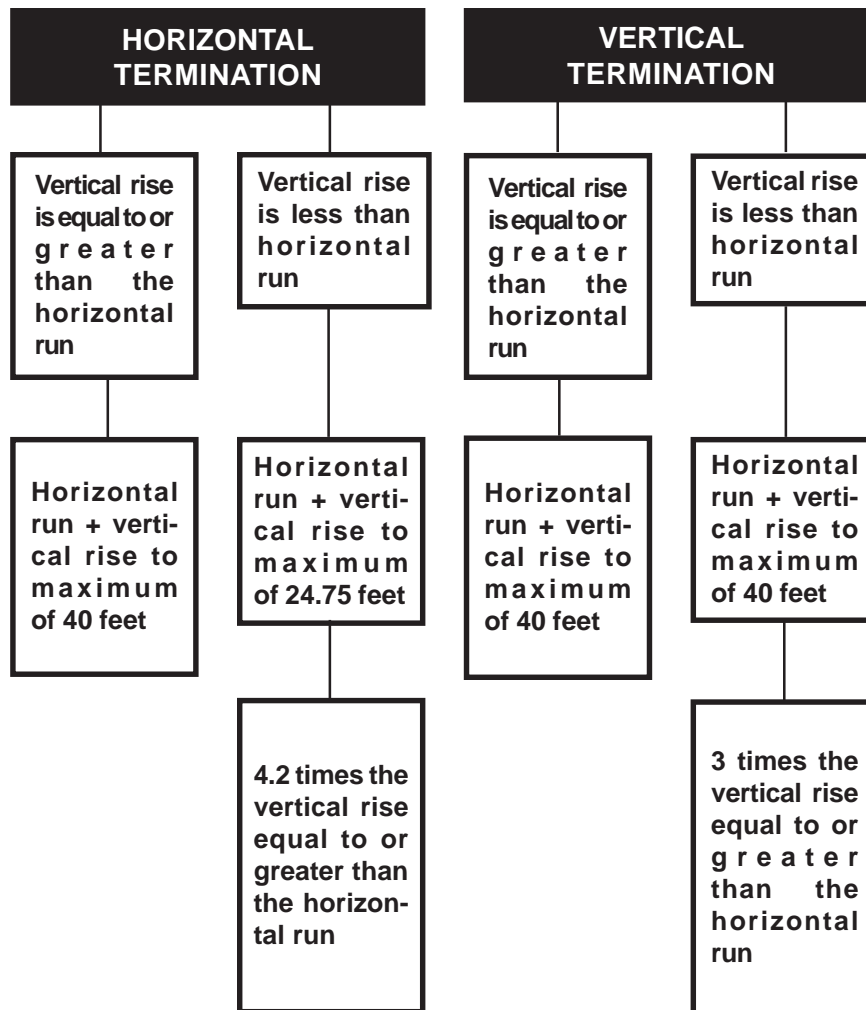


## SPECIAL VENT INSTALLATION

### PERISCOPE TERMINATION

Use the GD401 periscope kit to locate the air termination above grade. The periscope must be installed so that when final grading is completed, the bottom air slot is located a minimum of 12 inches above grade.



**VENTING APPLICATION FLOW CHART**

DEFINITIONS	
for the following symbols used in the venting calculations and examples are:	
>	- greater than
≥	- equal to or greater than
<	- less than
≤	- equal to or less than
$H_T$	- total of both horizontal vent lengths ( $H_R$ ) and offsets ( $H_O$ ) in feet
$H_R$	- combined horizontal vent lengths in feet
$H_O$	- offset factor: .03(total degrees of offset - 135°*) in feet
$V_T$	- combined vertical vent lengths in feet

ELBOW VENT LENGTH VALUES		
	feet	inches
1°	0.03	0.5
15°	0.45	6.0
30°	0.9	11.0
45°*	1.35	16.0
90°*	2.7	32.0

\* the first 45° and 90° offset has a zero value and is shown in the formula as -45° and -90° respectively or -135° when combined.

## HORIZONTAL TERMINATION

when  $(H_T) \leq (V_T)$

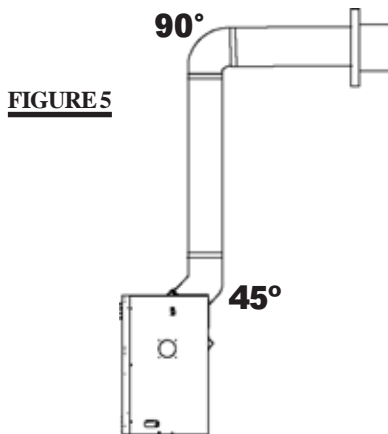
Simple venting configuration (only one 45° and 90° elbow)

For vent configurations requiring more than one 45° and 90° elbow, the following formulas apply:

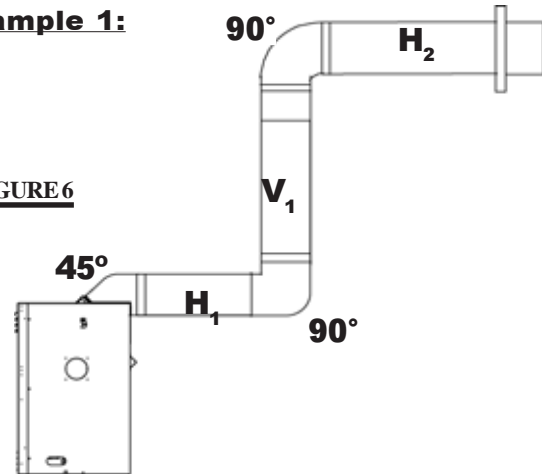
**Formula 1:**  $H_T \leq V_T$

**Formula 2:**  $H_T + V_T \leq 40$  feet

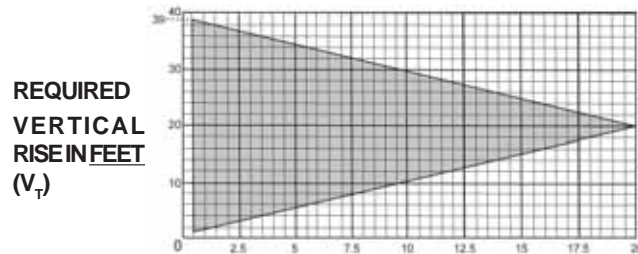
**Example 1:**



**FIGURE 5**



**FIGURE 6**



REQUIRED VERTICAL RISE IN FEET ( $V_T$ )

CALCULATED HORIZONTAL VENT RUN PLUS OFFSETS IN FEET ( $H_T$ )

The shaded area within the lines represents acceptable values for  $H_T$  and  $V_T$ .

$$\begin{aligned}
 V_1 &= 8 \text{ ft} \\
 V_T &= V_1 = 8 \text{ ft} \\
 H_1 &= 2.5 \text{ ft} \\
 H_2 &= 2 \text{ ft} \\
 H_R &= H_1 + H_2 = 2.5 + 2 = 4.5 \text{ ft} \\
 H_O &= .03(\text{one } 45^\circ \text{ elbow} + \text{two } 90^\circ \text{ elbows} - 135^\circ) \\
 &= 0.3(225 - 135^\circ) = 2.7 \text{ ft} \\
 H_T &= H_R + H_O = 4.5 + 2.7 = 7.2 \text{ ft}
 \end{aligned}$$

$$H_T + V_T = 7.2 + 8 = 15.2 \text{ ft}$$

Formula 1:  $H_T \leq V_T$   
 $7.2 \leq 8$

Formula 2:  $H_T + V_T \leq 40$  feet  
 $15.2 \leq 40$

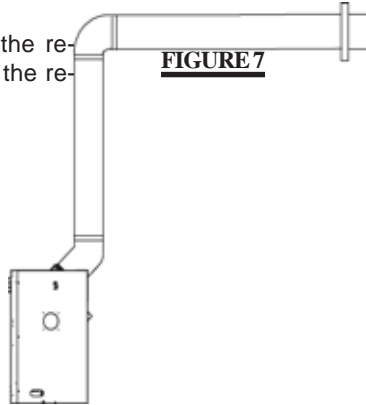
Since both formulas are met, this vent configuration is acceptable.

# HORIZONTAL TERMINATION

when  $(H_T) > (V_T)$

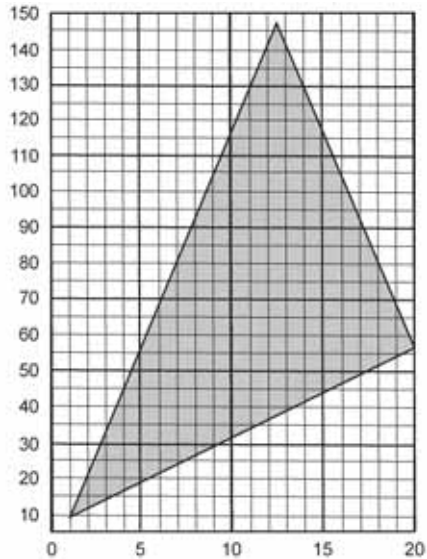
Simple venting configuration (only one 45° and 90° elbow)

See graph to determine the required vertical rise  $V_T$  for the required horizontal run  $H_T$ .



**FIGURE 7**

REQUIRED VERTICAL RISE IN INCHES ( $V_T$ )



HORIZONTAL VENT RUN PLUS OFFSETS IN FEET (HT)

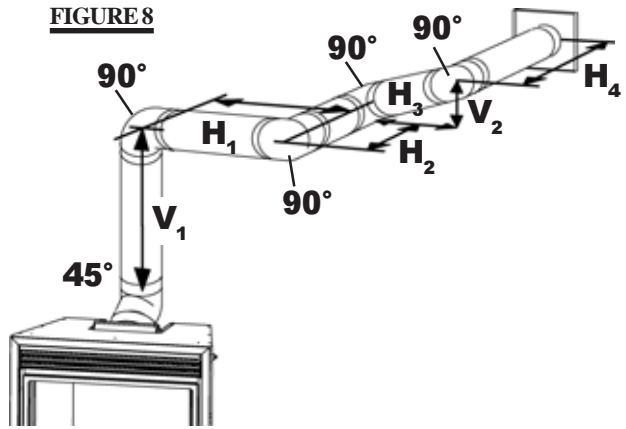
The shaded area within the lines represents acceptable values for  $H_T$  and  $V_T$ .

For vent configurations requiring more than one 45° and 90° elbow the following formulas apply:

**Formula 1:**  $H_T \leq 4.2 V_T$

**Formula 2:**  $H_T + V_T \leq 24.75$  feet

**Example 2:**



**FIGURE 8**

- $V_1 = 4$  ft
- $V_2 = 1.5$  ft
- $V_T = V_1 + V_2 = 4$  ft +  $1.5$  ft =  $5.5$  ft
- $H_1 = 2$  ft
- $H_2 = 1$  ft
- $H_3 = 1$  ft
- $H_4 = 1.5$  ft
- $H_R = H_1 + H_2 + H_3 + H_4 = 2 + 1 + 1 + 1.5 = 5.5$  ft
- $H_O = .03(\text{one } 45^\circ \text{ elbow} + \text{four } 90^\circ \text{ elbows} - 135^\circ)$   
 $= .03(405 - 135) = 8.1$  ft
- $H_T = H_R + H_O = 5.5 + 8.1 = 13.6$  ft
- $H_T + V_T = 13.6 + 5.5 = 19.1$  ft

Formula 1:  $H_T \leq 4.2 V_T$   
 $4.2 V_T = 4.2 \times 5.5 = 23.1$  ft  
 $13.6 \leq 23.1$

Formula 2:  $H_T + V_T \leq 24.75$  feet  
 $19.1 \leq 24.75$

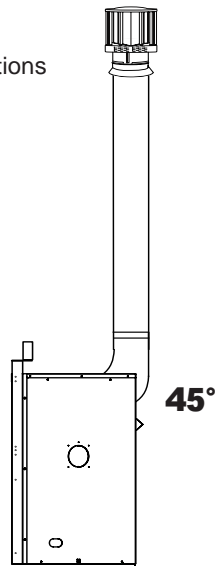
Since both formulas are met, this vent configuration is acceptable.

# VERTICAL TERMINATION

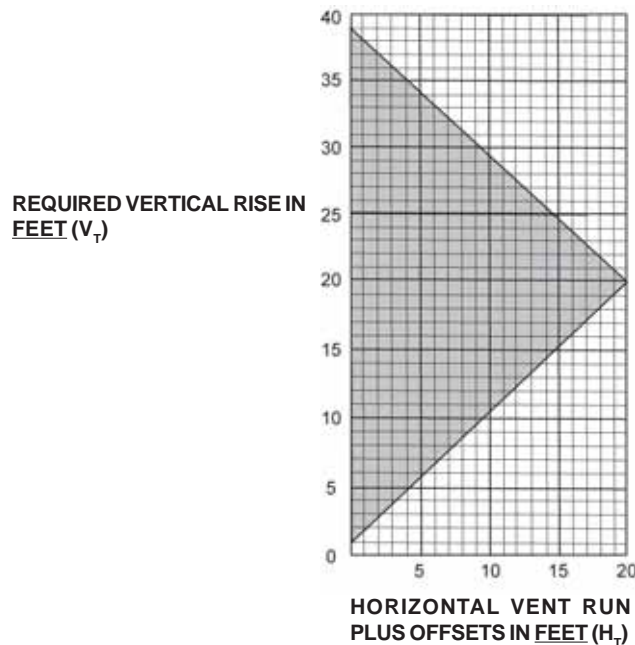
when  $(H_T) \leq (V_T)$

Simple venting configurations

**FIGURE 9**



See graph to determine the required vertical rise  $V_T$  for the required horizontal run  $H_T$ .



*The shaded area within the lines represents acceptable values for  $H_T$  and  $V_T$ .*

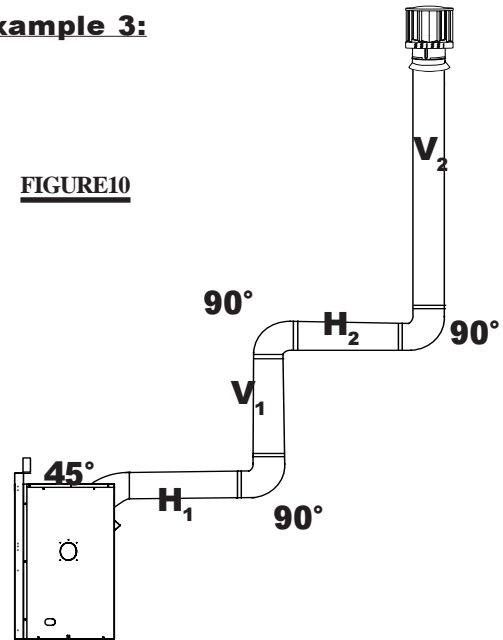
For vent configurations requiring more than one 45° and one 90° elbow, the following formulas apply:

**Formula 1:  $H_T \leq V_T$**

**Formula 2:  $H_T + V_T \leq 40$  feet**

**Example 3:**

**FIGURE 10**



- $V_1 = 5$  ft
- $V_2 = 10$  ft
- $V_T = V_1 + V_2 = 5 + 10 = 15$  ft
- $H_1 = 3$  ft
- $H_2 = 2.5$  ft
- $H_R = H_1 + H_2 = 3 + 2.5 = 5.5$  ft
- $H_o = .03(\text{one } 45^\circ \text{ elbow} + \text{three } 90^\circ \text{ elbows} - 135^\circ)$   
 $= .03(45+90+90+90-135)=5.4$
- $H_T = H_R + H_o = 5.5 + 5.4 = 10.9$  ft
- $H_T + V_T = 10.9 + 15 = 25.9$  ft

Formula 1:  $H_T \leq V_T$   
 $10.9 \leq 15$

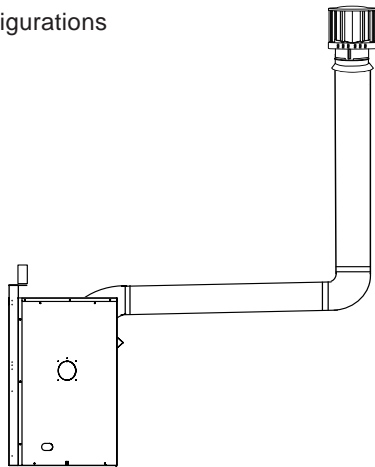
Formula 2:  $H_T + V_T \leq 40$  feet  
 $25.9 \leq 40$

Since both formulas are met, this vent configuration is acceptable.

# VERTICAL TERMINATION

when  $(H_T) > (V_T)$   
Simple venting configurations

**FIGURE 11**



$$\begin{aligned}
 V_1 &= 1 \text{ ft} \\
 V_2 &= 1.5 \text{ ft} \\
 V_T &= V_1 + V_2 = 1 + 1.5 = 2.5 \text{ ft} \\
 H_1 &= 6 \text{ ft} \\
 H_2 &= 2 \text{ ft} \\
 H_R &= H_1 + H_2 = 6 + 2 = 8 \text{ ft} \\
 H_o &= .03(\text{one } 45^\circ \text{ elbow} + \text{three } 90^\circ \text{ elbows} - 135^\circ) \\
 &= .03(45 + 90 + 90 + 90 - 135) = 5.4 \text{ ft} \\
 H_T &= H_R + H_o = 8 + 5.4 = 13.4 \text{ ft} \\
 H_T + V_T &= 13.4 + 2.5 = 15.9 \text{ ft}
 \end{aligned}$$

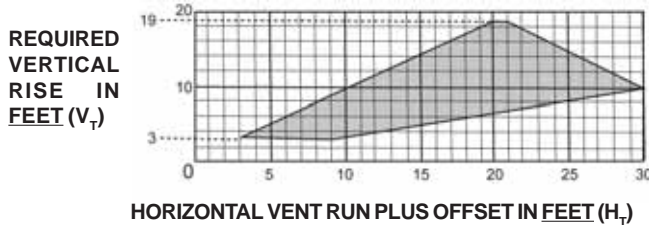
Formula 1:  $H_T \leq 3V_T$   
 $3V_T = 3 \times 2.5 = 7.5 \text{ ft}$   
 $13.4 > 7.5$

Since this formula is not met, this vent configuration is **unacceptable**.

Formula 2:  $H_T + V_T \leq 40 \text{ feet}$   
 $15.9 \leq 40$

Since only formula 2 is met, this vent configuration is unacceptable and a new fireplace location or vent configuration will need to be established to satisfy both formulas.

See graph to determine the required vertical rise  $V_T$  for the required horizontal run  $H_T$ .

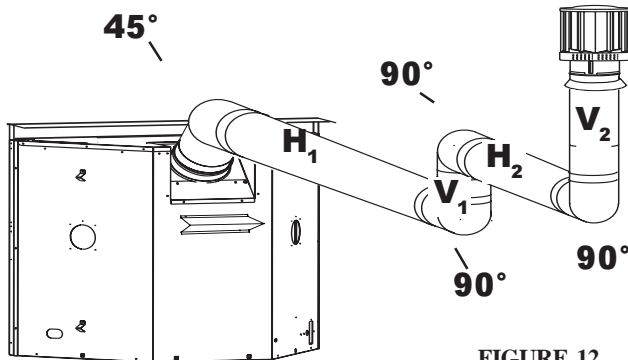


The shaded area within the lines represents acceptable values for  $H_T$  and  $V_T$ .

For vent configurations requiring more than one 45° and one 90° elbow, the following formulas apply:

**Formula 1:**  $H_T \leq 3V_T$   
**Formula 2:**  $H_T + V_T \leq 40 \text{ feet}$

**Example 4:**



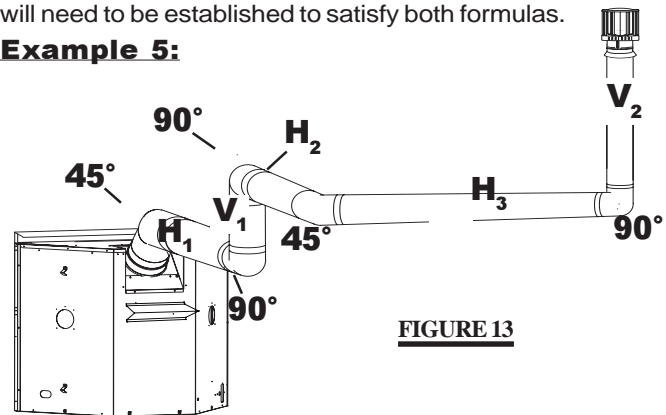
**FIGURE 12**

$$\begin{aligned}
 V_1 &= 1.5 \text{ ft} \\
 V_2 &= 8 \text{ ft} \\
 V_T &= V_1 + V_2 = 1.5 + 8 = 9.5 \text{ ft} \\
 H_1 &= 1 \text{ ft} \\
 H_2 &= 1 \text{ ft} \\
 H_3 &= 10.75 \text{ ft} \\
 H_R &= H_1 + H_2 + H_3 = 1 + 1 + 10.75 = 12.75 \text{ ft} \\
 H_o &= .03(\text{three } 90^\circ \text{ elbows} + \text{two } 45^\circ \text{ elbows} - 135^\circ) \\
 &= .03(90 + 90 + 90 + 45 + 45 - 135) = 6.75 \text{ ft} \\
 H_T &= H_R + H_o = 12.75 + 6.75 = 19.5 \text{ ft} \\
 H_T + V_T &= 19.5 + 9.5 = 29 \text{ ft}
 \end{aligned}$$

Formula 1:  $H_T \leq 3V_T$   
 $3V_T = 3 \times 9.5 = 28.5 \text{ ft}$   
 $19.5 \leq 28.5$

Formula 2:  $H_T + V_T \leq 40 \text{ feet}$   
 $29 \leq 40$

Since both formulas are met, this vent configuration is acceptable.



**FIGURE 13**

# INSTALLATION

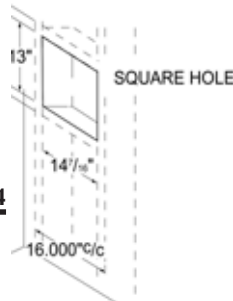
## WALL AND CEILING PROTECTION

**NOTE: HORIZONTAL TERMINATION:** A clearance to combustibles of 1" at the bottom and sides of the vent and 2" at the top must be maintained when penetrating combustible walls. The firestop spacer (W010-1778) supplied with the unit must be used to maintain these clearances.

**VERTICAL TERMINATION:** Only a clearance to combustibles of 1" all around the vent pipe is required.

### HORIZONTAL INSTALLATION

This application occurs when venting through an exterior wall. Having determined the air terminal location, cut and frame a hole in an exterior wall with a minimum opening as required. See Note above.

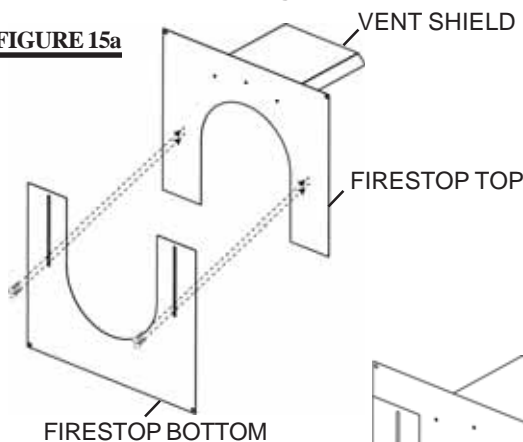


**FIGURE 14**

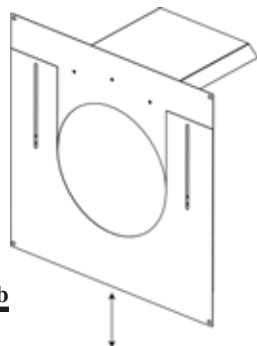
### ADJUSTABLE FIRESTOP

Apply a bead of caulking all around and place the firestop top, so that the vent shield covers the top of the vent within the opening. Place the firestop bottom against the firestop top and secure the two together. Adjust the assembly to ensure it is tight to the vent. Secure firestop to wall. This restricts cold air from being drawn into the room or around the fireplace. Ensure that both spacer and shield maintain the required clearance to combustibles. Once the vent pipe / liner is installed in its final position, apply sealant between the pipe / liner and the firestop spacer. See figures 15a-c.

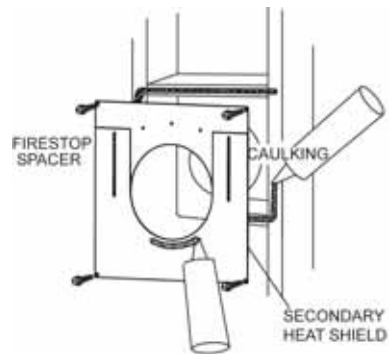
**FIGURE 15a**



**FIGURE 15b**

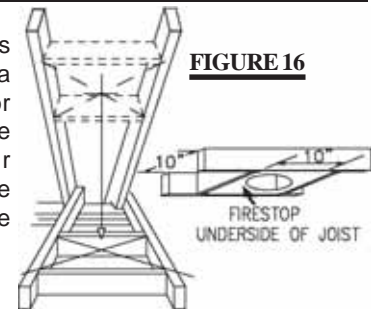


**FIGURE 15c**



### VERTICAL INSTALLATION

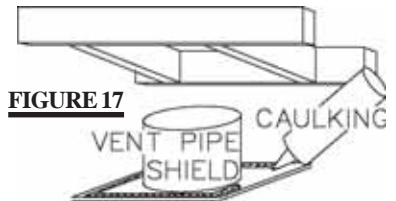
This application occurs when venting through a roof. Installation kits for various roof pitches are available from your Continental® dealer. See Accessories to order the specific kit required.



1. Determine the air terminal location, cut and frame 10 inch openings in the ceiling and the roof to provide the minimum 1 inch clearance between the fireplace pipe / liner and any combustible material. Try to center the exhaust pipe location midway between two joist to prevent having to cut them. Use a plumb bob to line up the center of the openings. **DO NOT FILL THIS SPACE WITH ANY TYPE OF MATERIAL.** A vent pipe shield will prevent any materials such as insulation, from filling up the 1" air space around the pipe. Nail headers between the joist for extra support.

2. Apply a bead of caulking (not supplied) to the framework or to the Wolf Steel vent pipe shield

**FIGURE 17**



and secure over the opening in the ceiling. A firestop must be placed on the bottom of each framed opening in a roof or ceiling that the venting system passes through. Apply a bead of caulking all around and place a firestop spacer over the vent shield to restrict cold air from being drawn into the room or around the fireplace. Ensure that both spacer and shield maintain the required clearance to combustibles. Once the vent pipe / liner is installed in its final position, apply sealant between the pipe / liner and the firestop spacer.

# USING FLEXIBLE VENT COMPONENTS

Use only approved aluminum flexible liner kits marked:



"Wolf Steel Approved Venting" as identified by the stamp only on the 8" outer liner.

For safe and proper operation of the fireplace, follow the venting instructions exactly.

All inner exhaust and outer intake vent pipe joints may be sealed using either Red RTV high temp silicone sealant or

Black high temp Mill Pac with the exception of the fireplace exhaust flue collar which must be sealed using Mill Pac (not supplied).

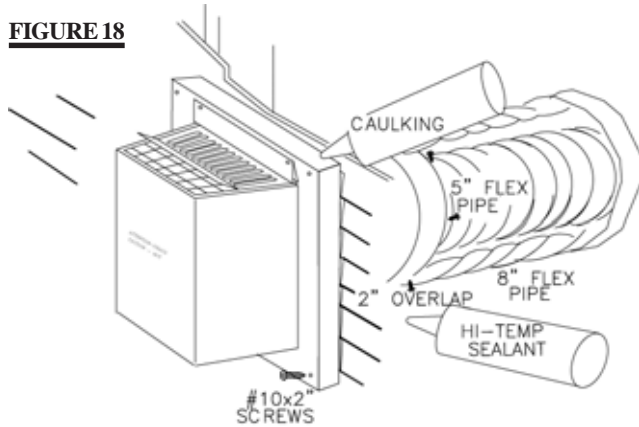
Do not allow the inside liner to bunch up on horizontal or vertical runs and elbows. Keep it pulled tight. A 1/4" air gap all around between the inner liner and outer liner is required for safe operation. A spacer is required at the start, middle and end of each elbow to ensure this gap is maintained. Use a firestop when penetrating interior walls, floor or ceiling.

## HORIZONTAL AIR TERMINAL INSTALLATION

1. Stretch the 5" diameter aluminum flexible liner to the required length taking into account the additional length needed for the finished wall surface. Slip the liner a minimum of 2" over the inner sleeve of the air terminal and secure with 3 #8 screws. Apply a heavy bead of the high temperature sealant.

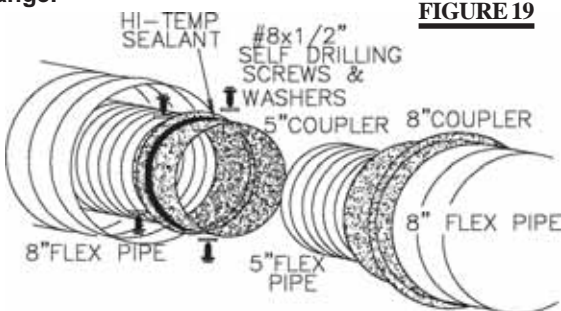
2. Using the 8" diameter flexible aluminum liner, slide over the outer combustion air sleeve of the air terminal and secure with 3 #8 screws. Seal as before.

FIGURE 18



The air terminal mounting plate may be recessed into the exterior wall or siding by 1 1/2", the depth of the return flange.

FIGURE 19



3. Insert the liners through the firestop maintaining the required clearance to combustibles. Holding the air terminal (lettering in an upright, readable position), secure to the exterior wall and make weather tight by sealing with caulking (not supplied).

4. Apply a heavy bead of the high temperature sealant, Mill Pac, to the inside of the 5" liner approximately 1" from the end. Slip the liner a minimum of 2" over the fireplace vent collar and secure with 3 #8 screws.

5. Using the 8" diameter flexible aluminium liner, apply sealant, slide a minimum of 2" over the fireplace combustion air collar and secure with 3 #8 screws.

6. If more liner needs to be used to reach the fireplace, couple them together as illustrated. The vent system must be supported approximately every 3 feet for both vertical and horizontal runs. Use noncombustible strapping to maintain the minimum 1" clearance to combustibles.

## VERTICAL AIR TERMINAL INSTALLATION

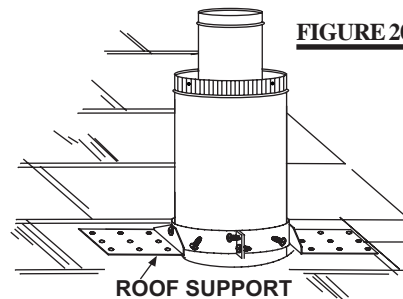


FIGURE 20

1. Fasten the roof support to the roof using the screws provided. The roof support is optional. In this case the venting is to be adequately supported using either an alternate method suitable to the authority

having jurisdiction or the optional roof support.

2. Stretch the exhaust to the required length. Slip the liner a minimum of 2" over the inner sleeve of the air terminal and secure with 3 #8 screws. Seal using a heavy bead of the high temperature sealant.

3. Repeat using air intake vent pipe.

4. Thread the air terminal pipe assembly down through the roof. The air terminal must be located vertically and plumb. Attach the air terminal assembly to the roof support, ensuring that a minimum 16" of air terminal will penetrate the roof when fastened.

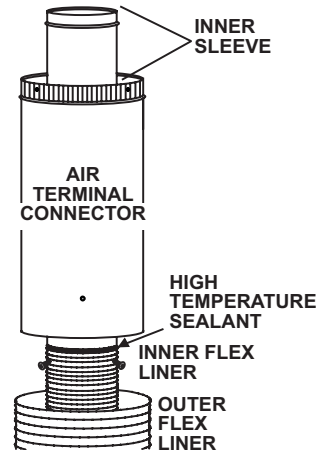
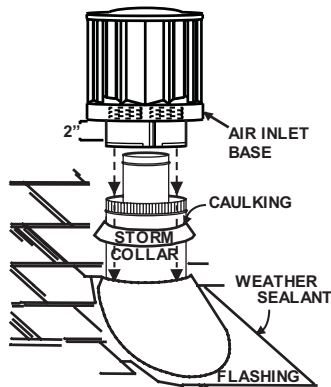


FIGURE 21

**DO NOT CLAMP THE FLEXIBLE ALUMINIUM LINER.**

5. Remove nails from the shingles, above and to the sides of the chimney. Place the flashing over the air terminal and slide it underneath the sides and upper edge of the shingles. Ensure that the air terminal is properly centred within the flashing, giving a 3/4" margin all around. Fasten to the roof. Do **not** nail through the lower portion of the flashing. Make weather-tight by sealing with caulking. Where possible, cover the sides and top edges of the flashing with roofing material.

6. Apply a heavy bead of weatherproof caulking 2 inches above the flashing. Slide the storm collar around the air terminal and down to the caulking. Tighten to ensure that a weather-tight seal between the air terminal and the collar is achieved. Attach the other storm collar centred between the air intake vent pipe and the air exhaust slots onto the air terminal. Tighten securely. Attach the vertical rain cap.



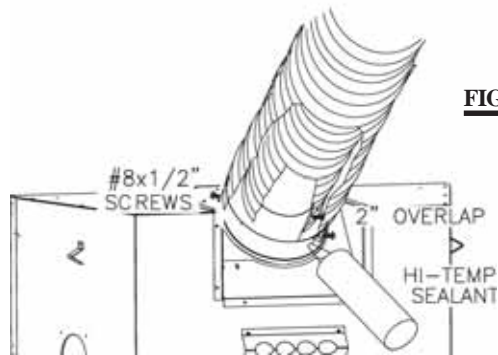
**FIGURE 22**

Spacers are attached to the exhaust liner at predetermined intervals to maintain a 1-1/4" air gap to the air intake vent pipe. These spacers must not be removed.

### FIREPLACE VENT CONNECTION

1. Install the 5 inch diameter aluminium flexible liner to the fireplace. Secure with 3 screws and flat washers. Seal the joint and screw holes using the high temperature sealant Mill Pac.

2. Install the 8 inch diameter aluminium flexible liner to the fireplace. Attach and seal the joints.



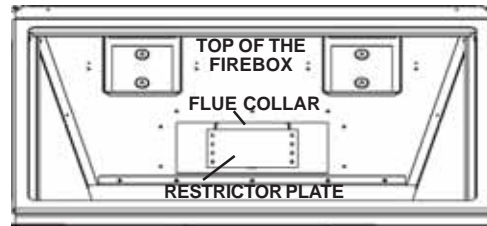
**FIGURE 23**

### RESTRICTING VERTICAL VENTS

Vertical terminations may display a very active flame. As this appearance is not desirable, the vent exit must be restricted using restrictor plate, W500-0205. This reduces the velocity of the exhaust gases, slowing down the flame pattern and creating a more traditional appearance.

Remove the two screws on either side of the exhaust collar inside the firebox. Install the plate as shown. The plate is adjustable depending on the required restriction. Replace the screws.

**FIGURE 24**



### GAS INSTALLATION

*Proceed once the vent installation is complete.*

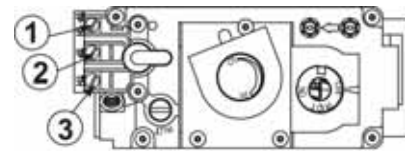
1. Move the fireplace into position and secure using the nailing tabs and/or secure to the floor through the 1/4" diameter holes located at either end of the base.

2. Route a 3/8" N.P.T. black iron gas line, 1/2" type-L copper tubing or equivalent to the fireplace.

3. For ease of accessibility, an optional remote wall switch or millivolt thermostat may be installed in a convenient location. Route 2-strand (solid core) millivolt wire through the electrical hole located at the bottom left side of the unit. The recommended maximum lead length depends on wire size:

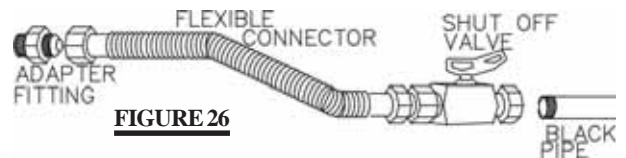
WIRE SIZE	MAX. LENGTH
14 gauge	100 feet
16 gauge	60 feet
18 gauge	40 feet

Attach the two leads to terminals 1 and 3 located on the gas valve.



**FIGURE 25**

4. Install rigid black pipe, 1/2" type-L copper tubing or, if local codes permit, a 3/8" flex connector and shutoff valve to the gas line and the fireplace gas valve.



**FIGURE 26**

Seal and tighten securely. An adapter fitting is required between the gas valve and the copper tubing or flex connector. *Do not kink flex connector.*

5. Check for gas leaks by brushing on a soap and water solution. *Do not use open flame.*

*Do not connect either the wall switch, thermostat or gas valve to electricity (110 volts).*

*Purge all gas lines with the glass door of the fireplace removed. Assure that a continuous gas flow is at the burner before re-installing the door.*

## MOBILE HOME INSTALLATION

This appliance may be installed as an OEM (Original Equipment Manufacturer) installation in a manufactured home or mobile home and must be installed in accordance with the manufacturer's instructions and the Manufactured Home Construction and Safety Standard, Title 24 CFR, Part 3280, in the United States or the Mobile Home Standard, CAN/CSA Z240 MH Series, in Canada. This appliance is only for use with the type(s) of gas indicated on the rating plate. A conversion kit is supplied with the mobile home appliance.

This Mobile/Manufactured Home Listed appliance comes factory equipped with a means to secure the unit.

The fireplace is equipped with two 1/4" diameter holes located in the front left and right corners of the base. For mobile home installations, the fireplace must be fastened in place. Use #10 hex head screws, inserted through the holes in the base to secure.

Always turn off the pilot and the fuel supply at the source, prior to moving the mobile home.

After moving the mobile home and prior to lighting the fireplace, ensure that the logs are positioned correctly.

This appliance may be installed in an aftermarket permanently located, manufactured (mobile) home, where not prohibited by local codes.

This appliance is only to be used with the type of gas indicated on the rating plate. This appliance is not convertible for use with other gases, unless a certified kit is used.

### Conversion Kits

The mobile home appliance is field convertible between Natural Gas (NG) and Propane (LP).

To convert from one gas to another consult your Continental® dealer/distributor.

## FRAMING

**Note:** In order to avoid the possibility of exposed insulation or vapour barrier coming in contact with the fireplace body, it is recommended that the walls of the fireplace enclosure be "finished" (ie: drywall/sheetrock), as you would finish any other outside wall of a home. This will ensure that clearance to combustibles is maintained within the cavity.

It is best to frame your fireplace after it is positioned and the vent system is installed. Use 2x4's and frame to local building codes.

It is not necessary to install a hearth extension with this fireplace system.

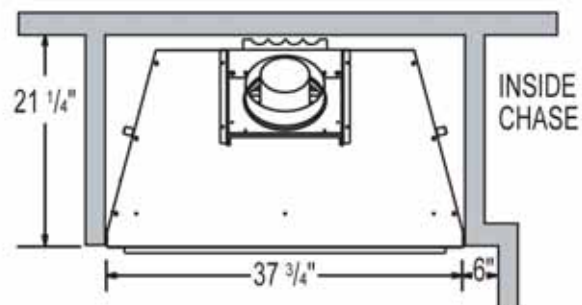
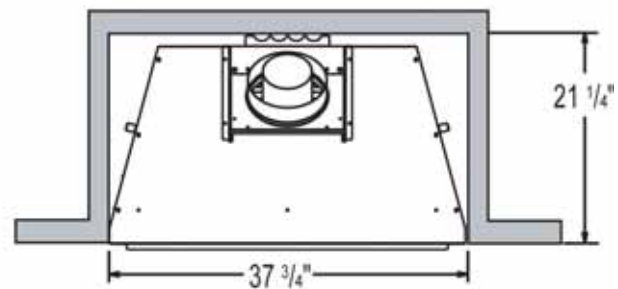
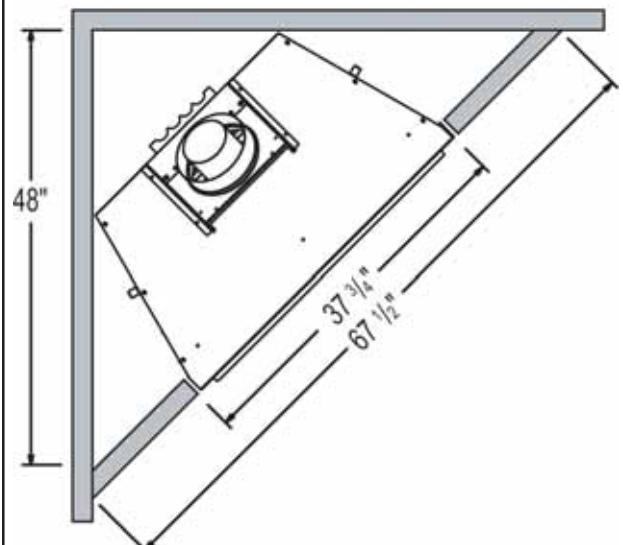
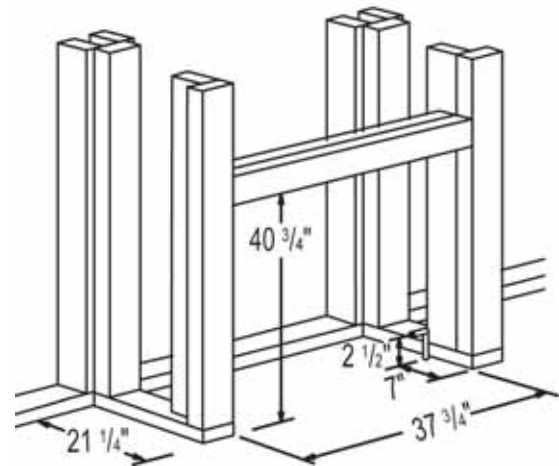
When roughing in the fireplace, raise the fireplace to accommodate for the thickness of the finished floor materials, i.e. tile, carpeting, hard wood, which if not planned for will interfere with the opening of the lower access door and the installation of many decorative flashing accessories.

Objects placed in front of the fireplace should be kept a minimum of 48" away from the front face.

Combustible materials may be installed flush with the front of the fireplace but must not cover or protrude past any of the black face-areas of the fireplace. Non-combustible material (brick, stone or ceramic tile) may protrude in these areas.

## B36DF

FIGURE 27a-d



## NAILING TAB INSTALLATION

1) Attach the nailing tabs to the corner posts using the 2 sheet metal screws supplied. Secure through the centre of the top and bottom slots in the nailing tab and then through the existing holes in the corner posts.

If there are no existing holes, follow these instructions:

Position the nailing tab so that the front face is offset with the front edge of the corner post (approx. 1/2"). Centre the nailing tab vertically on the corner post. **Figure 28 a.**

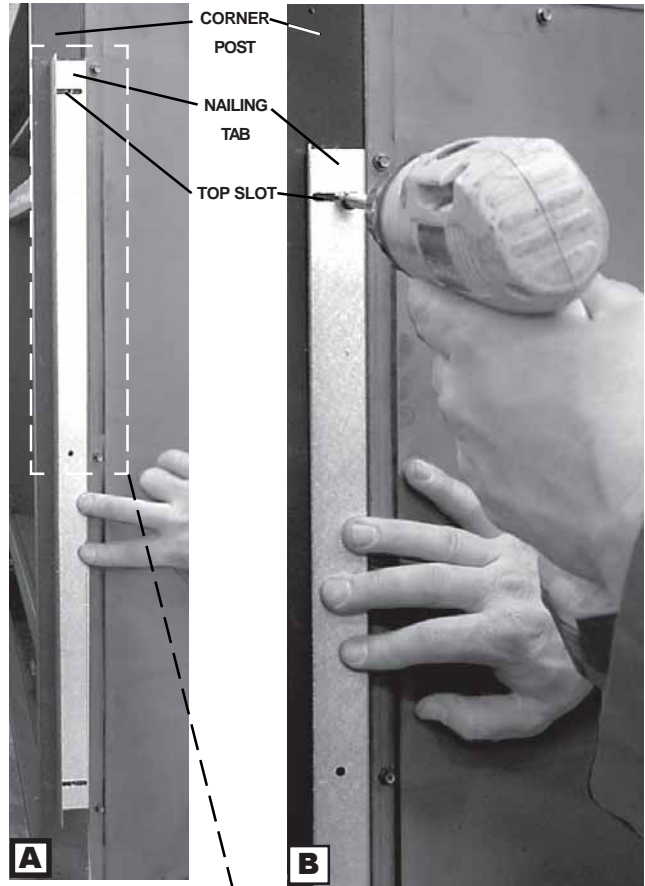
Drill through the centre of the top and bottom slots in the nailing tab. Secure using the two sheet metal screws supplied. This allows the nailing tab to slide back and forth for desired framing. **Figure 28 b.**

2) To determine the final location of the nailing tab you must first determine the thickness of your finishing material (i.e. drywall). This will determine the dimension from the front edge of the corner post to the nailing tab. Once the nailing tab is in the desired location, drill through the centre hole of the nailing tab. Secure with a sheet metal screw\*. **Figure 28 c.**

\* Additional set screws may be installed.

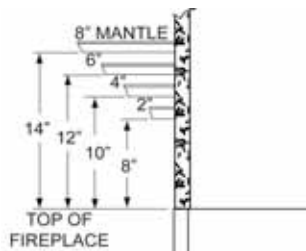


FIGURES 28a-c

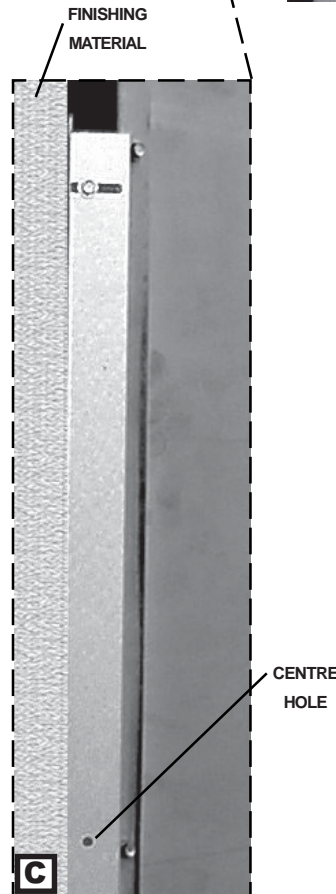
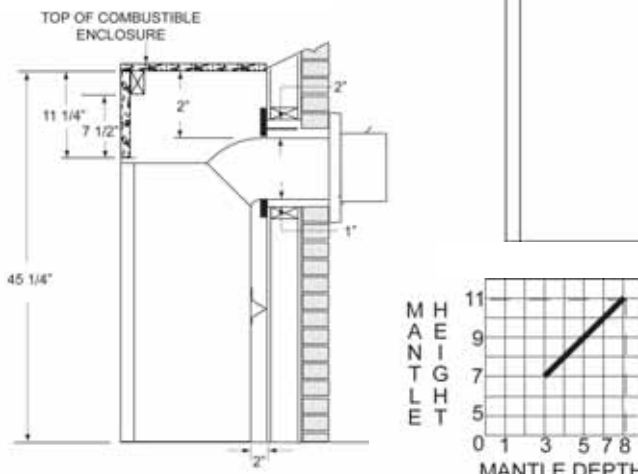


## MINIMUM MANTLE AND ENCLOSURE CLEARANCES

Combustible mantle clearance can vary according to the mantle depth. Use the graph to help evaluate the clearance needed. Curtains, above the fireplace, must not be positioned lower than the 8" distance required for the 2" combustible mantle. These same requirements apply to any combustibles protruding on either side of the fireplace.



FIGURES 29a-c

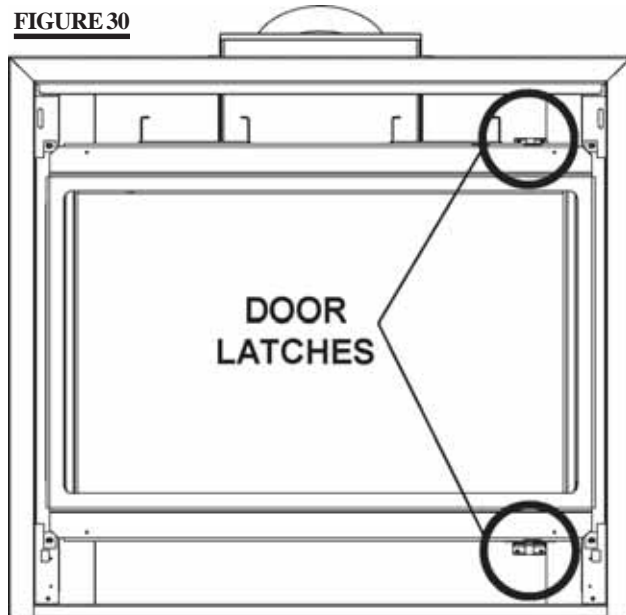


# FINISHING

## DOOR REMOVAL & INSTALLATION

The upper louvres must be removed to allow the door to be opened or closed. To access the lower door latch, open the valve control door. Release the top and bottom door latches, located at the right side of the door.

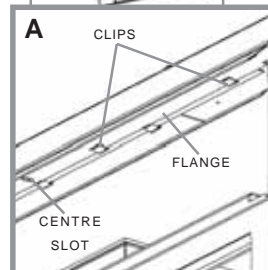
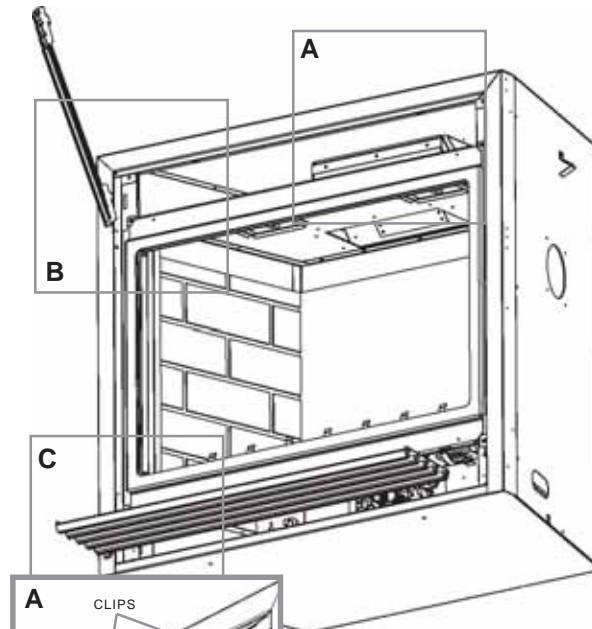
**FIGURE 30**



## L36 LOUVRE INSTALLATION

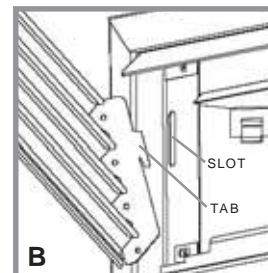
**Note:** The protective wrap is best removed when the assembly is at room temperature but this can be improved if the assembly is warmed, using a hair dryer or similar source.

**FIGURE 31 a-c**



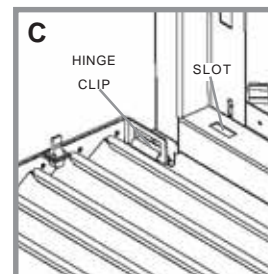
### HOOD

Attach the hood by pressing the top flange into the clips along the top of the louvre opening. Secure using a screw through the centre slot.



### UPPER LOUVRES

Insert the louvre tabs into the slots located at the top left and right corners of the unit.



### LOWER LOUVRES

Insert the hinge clips into the slots located at the bottom left and right corners of the unit.

To remove the louvres, pull the back tabs of the clips forward, while pushing the louvre assembly back. Lift the clip.

## LOG PLACEMENT

**PHAZER™** logs and glowing embers exclusive to Continental® Fireplaces, provide a unique and realistic glowing effect that is different in every installation. Take the time to carefully position the glowing embers for a maximum glowing effect.

Log colours may vary. During the initial use of the fireplace, the colours will become more uniform as colour pigments burn in during the heat activated curing process.



FIGURE 32a-d



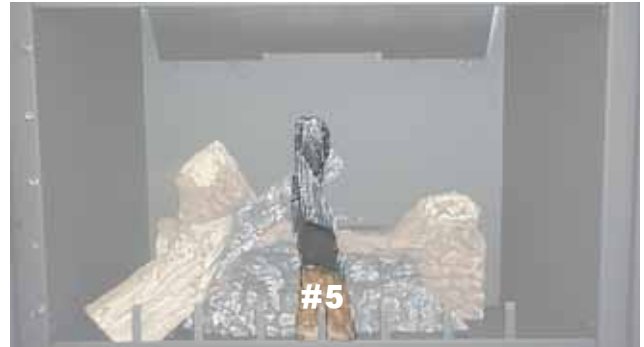
1. Place the rear log against the locator, pushing down, until it rests on the base, in front of the tabs.



2. Move the two small logs (#2 & #3) into position, lining up the studs located on the burner with the holes on the bottom of the logs. Ensure that the small logs sit flat on the burner.



3. Place the bottom of the left crossover log (#4) onto the locating stud on the left side of the log support. The top of the log should rest in the pocket on the rear log.



4. Position the heel of log #5 into the slot in the centre of the log support. The other end of the log rests in the pocket of the left log.



5. Place the bottom of the right crossover log (#6) onto the locating stud on the right side of the log support. The top of the log should rest in the pocket provided on the center log (#5).

## CHARCOAL EMBERS

Randomly place the charcoal embers along the front and sides of the log support tray in a realistic manner. *Fine dust found in the bottom of the bag should not be used.*

## GLOWING EMBERS

Tear the embers into pieces and place along the front row of ports covering all of the burner area in front of the small logs (#2 & #3). Care should be taken to shred the embers into thin, small irregular pieces as only the exposed edges of the fibre hairs will glow. *The ember material will only glow when exposed to direct flame; however, care should be taken to not block the burner ports.*

Blocked burner ports can cause an incorrect flame pattern, carbon deposits and delayed ignition. **PHAZER™** logs glow when exposed to direct flame. Use only certified "glowing embers" and **PHAZER™** logs available from your Continental® dealer.

## LOGO PLACEMENT

Remove the backing of the logo supplied and place on the glass viewing door, as indicated.



FIGURE 38

## OPTIONAL BLOWER INSTALLATION



**FIGURE 33**

INSTALLATION TO BE DONE BY A QUALIFIED INSTALLER and must be electrically connected and grounded in accordance with local codes. In the absence of local codes, use the current CSA C22.1 CANADIAN ELECTRICAL CODE IN

Canada or the ANSI/NFPA 70 NATIONAL ELECTRICAL CODE in the United States

**If the fireplace was not previously equipped with a blower:** route a grounded 2-wire, 60hz power cable to the receptacle / junction box relieved and insulated.

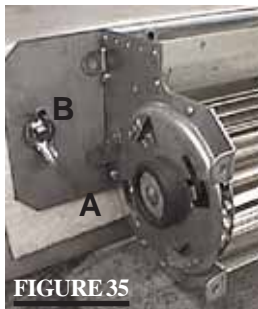
The three slots on the blower mounting bracket allow ease of adjustment when attaching the blower. For a quiet running blower, do not allow the assembly to sit on the firebox base.



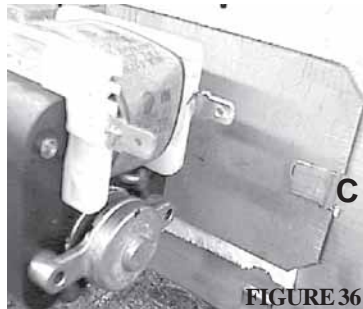
**FIGURE 34**

Slide the vibration reducing pad (A) into the clip (C) and up against the threaded stud (B) at the other end. The blower must be able to be positioned entirely onto the pad.

Tilt the blower onto its side. Slide it past the controls and into the clip (C). Secure to the threaded stud using the lock washer and wing nut provided. Ensure that the blower does not touch the fireplace base or the firebox.



**FIGURE 35**



**FIGURE 36**

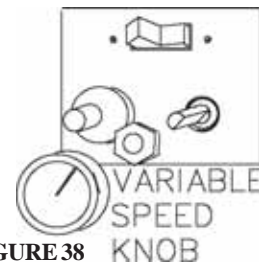
Attach the connectors from the black and white wires to the thermodisc and secure the thermodisc bracket to the unit at the bottom left of the unit using the ground screw supplied. Ensure that the thermodisc touches the firebox wall.

Attach the connectors from the black and red wires to the blower.

Attach and secure the variable speed switch using the nut provided. Plug the harness cord into the receptacle.



**FIGURE 37**



**FIGURE 38**

The wire harness provided in this kit is a universal harness. When installed, ensure that any excess wire is contained, preventing it from making contact with moving or hot objects.

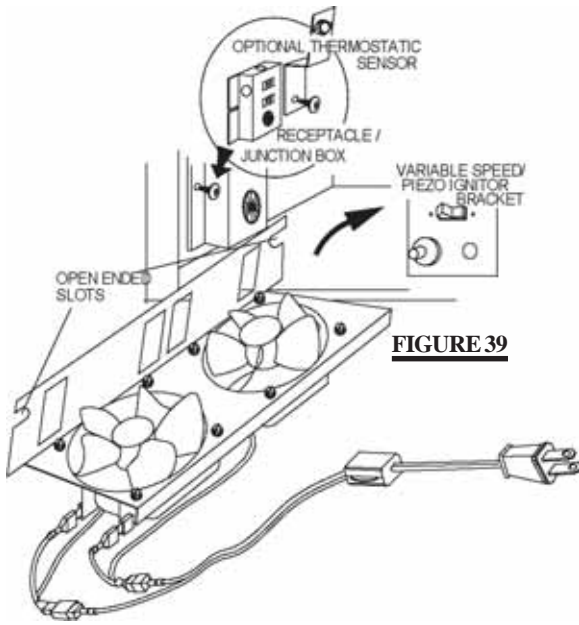
Because the blower is thermally activated, when turned on, it will automatically start approximately 10 minutes after lighting the fireplace and will run for approximately 30-45 minutes after the fireplace has been turned off. Use of the fan increases the output of heat.

Drywall dust will penetrate into the blower bearings, causing irreparable damage. Care must be taken to prevent drywall dust from coming into contact with the blower or its compartment. Any damage resulting from this condition is not covered by the warranty policy.

# OPTIONAL FAN INSTALLATION

**ELECTRICAL INSTALLATION TO BE DONE BY A QUALIFIED INSTALLER** and must be connected and grounded in accordance with local codes. In the absence of local codes, use the current CSA C22.1 CANADIAN ELECTRICAL CODE in Canada or the ANSI/NFPA 70 NATIONAL ELECTRICAL CODE in the United States.

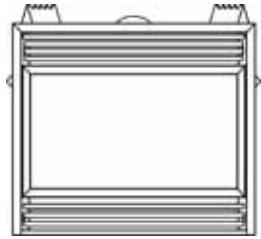
To safely install the fan, turn off the electricity first.



**FIGURE 39**

**If the fireplace was not previously equipped with a fan:** route a grounded 2-wire, 60hz power cable to the junction box. At this point, it must be strain relieved and insulated. The wire harness provided in this kit is a universal harness. When installed, ensure that any excess wire is contained, preventing it from making contact with moving or hot objects.

**FIGURE 40**



To ease installation of the fan, remove the valve control door (lower louvres) from the base of the fireplace.

Position the vibration reducing pad into the clip and onto the threaded stud at the other end, piercing a hole into the pad. The fan assembly must be able to be positioned entirely onto the pad.

Slide the fan assembly past the controls and into the clip. Secure using the lock washer and nut provided.

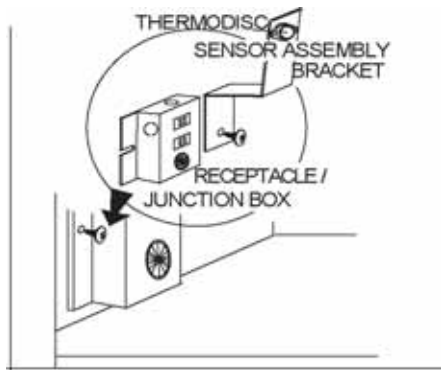
Plug the harness cord into the receptacle.

# GD36 THERMOSTATIC SENSOR CONTROL

This optional kit is meant to be used only in conjunction with the GD65 Fan Kit, shown above, which may be ordered from your Wolf Steel / Continental® dealer.

With the thermostatic sensor option, the fan, when turned on, becomes thermally activated, and will automatically run approximately 15-30 minutes after the fireplace has been lit and for approximately 30-45 minutes after the fireplace has been turned off.

**FIGURE 41**



Use of the fan increases the output of heat.

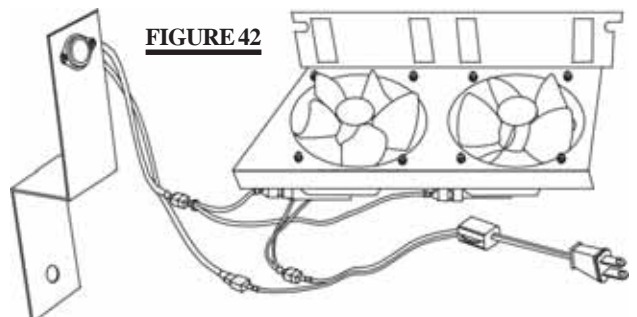
Unplug the power cord from the receptacle. Connect all wires as shown.

Secure the sensor assembly bracket to the unit next to the receptacle/junction box at the bottom left of the unit using the ground screw provided. Ensure that the thermodisc touches the firebox wall.

Plug the power cord back into the receptacle.

When installed, ensure that any excess wire is contained, preventing it from making contact with moving or hot objects.

**FIGURE 42**



# OPERATION / MAINTENANCE

## OPERATING INSTRUCTIONS

When lit for the first time, the fireplace will emit a slight odour for a few hours. This is a normal temporary condition caused by the curing of the logs and the "burn-in" of internal paints and lubricants used in the manufacturing process and will not occur again.

After extended periods of non-operation such as following

### FOR YOUR SAFETY READ BEFORE LIGHTING:

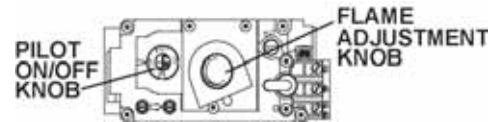
- This fireplace is equipped with a pilot which must be lit by hand while following these instructions exactly.
- Before operating smell all around the fireplace area for gas and next to the floor because some gas is heavier than air and will settle on the floor
- Use only your hand to turn the gas control knob. Never use tools. If the knob will not turn by hand, do not try to repair it. Call a qualified service technician. Force or attempted repair may result in a fire or explosion.
- Do not use this fireplace if any part has been under water. Immediately call a qualified service technician to inspect the fireplace and replace any part of the control system and any gas control which has been under water.

a vacation or a warm weather season, the fireplace may emit a slight odour for a few hours. This is caused by dust particles in the heat exchanger burning off. In both cases, open a window to sufficiently ventilate the room.

*Purge the gas line with the glass door removed. Assure that a continuous gas flow is at the burner before re-installing the door.*

### WHAT TO DO IF YOU SMELL GAS


- Turn off all gas to the fireplace.
- Open windows.
- Do not try to light any appliance.
- Do not touch any electric switch; do not use any phone in your building.
- Immediately call your gas supplier from a neighbour's phone. Follow the gas supplier's instructions.
- If you cannot reach your gas supplier, call the fire department.





## LIGHTING INSTRUCTIONS

**WARNING:** The gas valve has an interlock device which will not allow the pilot burner to be lit until the thermocouple has cooled. Allow approximately 60 seconds for the thermocouple to cool.

When lighting and re-lighting, the gas knob cannot be turned from pilot to off unless the knob is **depressed slightly**.

- Stop! Read the above safety information on this label.
- Turn off all electric power to the fireplace.
- Turn the gas knob clockwise  to off.
- Wait five (5) minutes to clear out any gas. If you smell gas including near the floor. Stop! Follow "B" in the above safety information on this label. If you don't smell gas go the next step.

- Turn gas knob counter-clockwise  to pilot.
- Depress slightly and hold gas knob while lighting the pilot with the push button ignitor. Keep knob depressed for one minute, then release. If pilot does not continue to burn, repeat steps 3 through 5.
- With pilot lit, depress and turn gas knob counter-clockwise  to on.
- If equipped with remote on-off switch/thermostat, main burner may not come on when you turn valve to on. Remote switch must be in the on position to ignite burner.
- Turn on all electric power to the fireplace.

### TO TURN OFF GAS

- Turn off all electric power to the fireplace if service is to be performed.
- Push in gas control knob slightly and turn clockwise  to off. Do not force.

## MAINTENANCE

**Turn off the gas and electrical power before servicing the fireplace.**

**CAUTION:** Label all wires prior to disconnection when servicing controls. Wiring errors can cause improper and dangerous operation. Verify proper operation after servicing. This fireplace and its venting system should be inspected before use and at least annually by a qualified service person. The fireplace area must be kept clear and free of combustible materials, gasoline or other flammable vapours and liquids. The flow of combustion and ventilation air must not be obstructed.

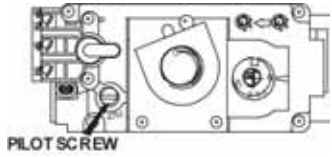
- In order to properly clean the burner and pilot assembly, remove the logs to expose both assemblies.
- Keep the control compartment, logs, burner, air shutter opening and the area surrounding the logs clean by vacuuming or brushing, *at least once a year*.

- Check to see that all burner ports are burning. Clean out any of the ports which may not be burning or are not burning properly.
- Check to see that the pilot flame is large enough to engulf the thermocouple and thermopile and reaches toward the burner with the third jet.
- Replace the cleaned logs.
- Check to see that the main burner ignites completely on all openings when the gas knob for the burner is turned on. A 5 to 10 second total light-up period is satisfactory. If ignition takes longer, consult your Continental® dealer / distributor.
- Check that the gasketing on the sides, top and bottom of the door is not broken or missing. Replace if necessary.

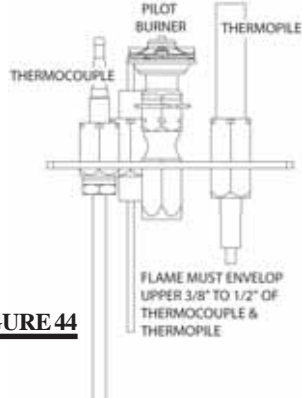
# ADJUSTMENTS

## PILOT BURNER ADJUSTMENT

Adjust the pilot screw to provide properly sized flame. Turn in a clockwise direction to reduce the gas flow.



**FIGURE 43**



**FIGURE 44**

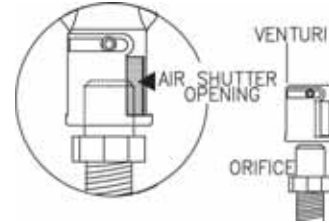
## VENTURI ADJUSTMENT

Air shutters have been factory set open according to the chart below:

	AIR SHUTTER
NG	1/16"
LP	3/8"

These settings are for the maximum horizontal vent run.- Adjustment may be required depending on fuel type, vent configuration and altitude.

Closing the air shutter will cause a more yellow flame, but can lead to carboning. Opening the air shutter will cause a more blue flame, but can cause flame lifting from the burner ports. The flame may not appear yellow immediately; allow 15 to 30 minutes for the final flame colour to be established.



**FIGURE 45**

*Air shutter adjustment must only be done by a qualified installer!*



**FIGURE 46**

**VENTURI COVER**

To access the air shutter, remove the two screws that secure the cover to the air housing, taking care not to damage the gasket.

**NOTE:** Ensure burner is seated onto orifice.

# REPLACEMENTS

Contact your dealer for questions concerning prices and availability of replacement parts. Normally all parts can be ordered through your Continental® dealer or distributor.

\* IDENTIFIES ITEMS WHICH ARE NOT ILLUSTRATED. FOR FURTHER INFORMATION, CONTACT YOUR CONTINENTAL® DEALER.

When ordering replacement parts always give the following information:

1. MODEL & SERIAL NUMBER OF FIREPLACE
2. INSTALLATION DATE OF FIREPLACE
3. PART NUMBER
4. DESCRIPTION OF PART
5. FINISH

## COMMON REPLACEMENT PARTS:

#	PART NO.	DESCRIPTION
1*	W225-0058	BLACK DOOR FRAME
2	W357-0001	PIEZO IGNITER
3	W680-0004	THERMOPILE
4	W680-0005	THERMOCOUPLE**
5	W010-0800	PROPANE GAS PILOT ASSEMBLY
5	W010-0801	NATURAL GAS PILOT ASSEMBLY
6	W455-0069	NATURAL GAS PILOT INJECTOR
6	W455-0067	PROPANE GAS PILOT INJECTOR
7	W455-0065	#45 NATURAL GAS ORIFICE
7	W455-0003	#54 PROPANE GAS ORIFICE
8	W725-0035	NATURAL GAS VALVE
8	W725-0043	PROPANE GAS VALVE
9*	W385-0334	CONTINENTAL® LOGO
10*	W750-0112	20FT OF WIRE
11	W010-0764	PAN BURNER
12	GL-639	LOG SET
13*	W361-0016	GLOWING EMBERS
14*	W550-0001	CHARCOAL EMBERS
15	W135-0183	BACK LOG (#1)
16	W135-0184	LEFT MIDDLE LOG (#2)
17	W135-0185	RIGHT MIDDLE LOG (#3)
18	W135-0186	LEFT CROSSOVER LOG (#4)
19	W135-0187	MIDDLE CROSSOVER LOG (#5)
20	W135-0188	RIGHT CROSSOVER LOG (#6)
21	W010-0454	GLASS c/w GASKET
22	W010-0516	BLACK DOOR C/W GLASS
23	W010-1778	ADJUSTABLE FIRESTOP
24*	W500-0205	RESTRICTOR

\*\* WARNING: THIS IS A FAST ACTING THERMOCOUPLE. IT IS AN INTEGRAL SAFETY COMPONENT. REPLACE ONLY WITH A FAST ACTING THERMOCOUPLE SUPPLIED BY WOLF STEEL LTD.

## FLEXIBLE VENT KITS

### GD420 (5 FT)

25*	W010-0772	5" FLEXIBLE ALUMINIUM LINER - (5 FT) C/W SPACERS
25*	W730-0012	8" FLEXIBLE ALUMINIUM LINER - (5 FT)

### GD430 (10 FT)

25*	W730-0013	8" FLEXIBLE ALUMINIUM LINER -(10 FT)
25*	W010-0773	5" FLEXIBLE ALUMINIUM LINER -(10 FT) C/W SPACERS
26*	W010-0810	WALL SUPPORT ASSEMBLY

## TERMINAL KITS

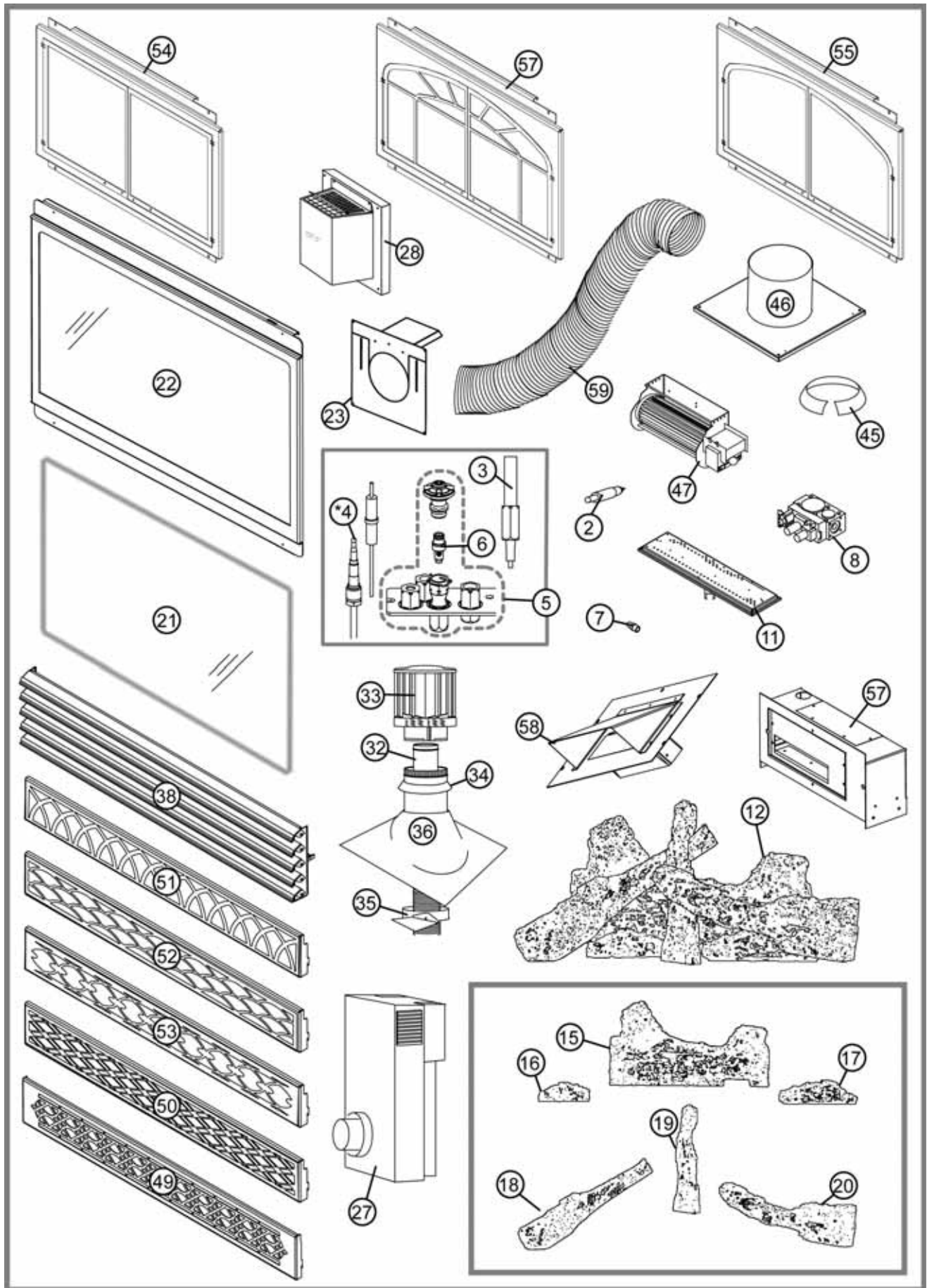
<b>27 PERISCOPE</b>	-	<b>GD401</b>
<b>28 WALL TERMINAL KIT</b>	-	<b>GD422</b>

## ROOF TERMINAL KITS

<b>29 1/12 TO 7/12 PITCH</b>	-	<b>GD410</b>
<b>30 8/12 TO 12/12 PITCH</b>	-	<b>GD411</b>
<b>31 FLAT ROOF</b>	-	<b>GD412</b>
32	W490-0074	5/8 INNER/OUTER SLEEVE
33	W670-0007	5/8 TERMINAL
34	W170-0086	STORM COLLAR
35	W010-0453	ROOF SUPPORT
36	W263-0065 /	ROOF FLASHING
	W263-0066 /	
	W263-0055	

## ACCESSORIES:

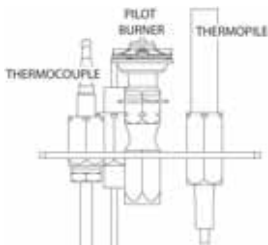
37*	W175-0166	5" COUPLER
37*	W175-0002	8" COUPLER
38	L36K	LOUVRE KIT - UPPER & LOWER - BLACK
38	L36PB	LOUVRE ASSEMBLY - POLISHED BRASS
38	L36AB	LOUVRE ASSEMBLY - ANTIQUE BRASS
38	L36SS	LOUVRE ASSEMBLY - BRUSHED STAINLESS STEEL
39*	W573-0007	10.3OZ TUBE HIGH TEMP SEALANT
40*	W690-0001	MILLIVOLT THERMOSTAT
41*	W660-0011	REMOTE CONTROL - ADVANTAGE PLUS
42*	W500-0028	FIRESTOP SPACER - FLEXIBLE VENTING
42*	W500-0163	FIRE STOP SPACER - RIGID VENTING
43*	W500-0206	TERMINAL EXTENSION PLATE
44*	W660-0013	MODULATING REMOTE
45	W170-0086	VENT PIPE COLLAR
46	W585-0092	VENT PIPE SHIELD
47	GZ550-1KT	BLOWER KIT
48*	GD36	THERMOSTATIC SENSOR CONTROL KIT FOR USE WITH GD65 ONLY
49	HOIK-2	HERITAGE ORNAMENTAL INSETS - BLACK
49	HOIG-2	HERITAGE ORNAMENTAL INSETS - GOLD PLATED
49	HOIKG-2	HERITAGE ORNAMENTAL INSETS - BLACK GOLD PLATED
49	HOIBC-2	HERITAGE ORNAMENTAL INSETS - BRUSHED COPPER PLATED
49	HOIBG-2	HERITAGE ORNAMENTAL INSETS - BRUSHED GOLD PLATED
50	DOIK-1	DIAMOND ORNAMENTAL INSETS - BLACK
50	DOIG-1	DIAMOND ORNAMENTAL INSETS - GOLD PLATED
50	DOIKG-1	DIAMOND ORNAMENTAL INSETS- BLACK GOLD PLATED
50	DOIBC-1	DIAMOND ORNAMENTAL INSETS- BRUSHED COPPER PLATED
50	DOIBG-1	DIAMOND ORNAMENTAL INSETS- BRUSHED GOLD PLATED
51	GOIK-1	GOTHIC ORNAMENTAL INSETS - BLACK
51	GOIG-1	GOTHIC ORNAMENTAL INSETS - GOLD PLATED
51	GOIKG-1	GOTHIC ORNAMENTAL INSETS - BLACK GOLD PLATED
51	GOIBC-1	GOTHIC ORNAMENTAL INSETS - BRUSHED COPPER PLATED
51	GOIBG-1	GOTHIC ORNAMENTAL INSETS - BRUSHED GOLD PLATED
52	SOIK-1	SEASHELL ORNAMENTAL INSETS - BLACK
52	SOIG-1	SEASHELL ORNAMENTAL INSETS - GOLD PLATED
52	SOIKG-1	SEASHELL ORNAMENTAL INSETS - BLACK GOLD PLATED
52	SOIBC-1	SEASHELL ORNAMENTAL INSETS -BRUSHED COPPER PLATED
52	SOIBG-1	SEASHELL ORNAMENTAL INSETS - BRUSHED GOLD PLATED
53	EOIK-1	ECLIPSE ORNAMENTAL INSETS - BLACK
53	EOIG-1	ECLIPSE ORNAMENTAL INSETS - GOLD PLATED
53	EOIKG-1	ECLIPSE ORNAMENTAL INSETS - BLACK GOLD PLATED
53	EOIBC-1	ECLIPSE ORNAMENTAL INSETS - BRUSHED COPPER PLATED
53	EOIBG-1	ECLIPSE ORNAMENTAL INSETS - BRUSHED GOLD PLATED
54	DK36-R	DOOR KIT, RECTANGULAR - BLACK
54	DK36-RG	DOOR KIT, RECTANGULAR - GOLD PLATED
55	DK36-A	DOOR KIT, ARCHED - BLACK
55	DK36-AG	DOOR KIT, ARCHED - GOLD PLATED
56	DK36-W	DOOR KIT, WEBBED - BLACK
56	DK36-WG	DOOR KIT, WEBBED - GOLD PLATED
57	GA-566	HOT AIR KIT
58	GA-72	HOT AIR EXHAUST KIT
59	GA-70	EXTENSION KIT 5FT
60*	W175-0235	CONVERSION KIT - NG TO LP
60*	W175-0236	CONVERSION KIT - LP TO NG
61*	GD808-KT	DECORATIVE PANELS - SANDSTONE
62*	PRP36-D	PORCELAIN PANELS



# TROUBLE SHOOTING GUIDE

BEFORE ATTEMPTING TO TROUBLESHOOT, PURGE YOUR UNIT AND INITIALLY LIGHT THE PILOT AND THE MAIN BURNER WITH THE GLASS DOOR OPENED.

SYMPTOM	PROBLEM	TEST SOLUTION	
Main burner goes out; pilot stays on.	Pilot flame is not large enough or not engulfing the thermopile	<ul style="list-style-type: none"> <li>- turn up pilot flame.</li> <li>- replace pilot assembly.</li> </ul>	
	Thermopile shorting	<ul style="list-style-type: none"> <li>- clean thermopile connection to the valve. Reconnect.</li> <li>- replace thermopile / valve.</li> </ul>	
	Remote wall switch wire is too long; too much resistance in the system.	<ul style="list-style-type: none"> <li>- shorten wire to correct length or wire gauge.</li> </ul>	
	Faulty thermostat or switch.	<ul style="list-style-type: none"> <li>- replace.</li> </ul>	
Main burner goes out; pilot goes out.	Refer to "MAIN BURNER GOES OUT; PILOT STAYS ON"		
	Vent is blocked	<ul style="list-style-type: none"> <li>- check for vent blockage.</li> </ul>	
	Vent is re-circulating	<ul style="list-style-type: none"> <li>- check joint seals and installation.</li> </ul>	
	5" flexible vent has become disconnected from fireplace.	<ul style="list-style-type: none"> <li>- re-attach to fireplace.</li> </ul>	
Pilot goes out when the gas knob is released. <b>The gas valve has an interlock device which will not allow the pilot burner to be lit until the thermocouple has cooled. Allow approximately 60 seconds for the thermocouple to cool.</b>	System is not correctly purged.	<ul style="list-style-type: none"> <li>- purge the gas line with the glass door removed.</li> </ul>	
	Out of propane gas.	<ul style="list-style-type: none"> <li>- fill the tank.</li> </ul>	
	Pilot flame is not large enough	<ul style="list-style-type: none"> <li>- turn up the pilot flame.</li> </ul>	
	Pilot flame is not engulfing the thermocouple.	<ul style="list-style-type: none"> <li>- gently twist the pilot head to improve the flame pattern around the thermocouple.</li> </ul>	
	Thermocouple shorting / faulty.	<ul style="list-style-type: none"> <li>- loosen and tighten thermocouple.</li> <li>- clean thermocouple and valve connection.</li> <li>- replace thermocouple.</li> <li>- replace valve.</li> </ul>	
	Faulty valve.	<ul style="list-style-type: none"> <li>- replace.</li> </ul>	
Pilot burning; no gas to main burner; gas knob is on 'HI'; wall switch / thermostat is on.	Thermostat or switch is defective.	<ul style="list-style-type: none"> <li>- connect a jumper wire across the wall switch terminals; if main burner lights, replace switch / thermostat.</li> </ul>	
	Wall switch wiring is defective.	<ul style="list-style-type: none"> <li>- disconnect the switch wires &amp; connect a jumper wire across terminals 1 &amp; 3; if the main burner lights, check the wires for defects and / or replace wires.</li> </ul>	
	Main burner orifice is plugged.	<ul style="list-style-type: none"> <li>- remove stoppage in orifice.</li> </ul>	
	Faulty valve.	<ul style="list-style-type: none"> <li>- replace.</li> </ul>	
Pilot will not light.	No spark at pilot burner	<ul style="list-style-type: none"> <li>- check if pilot can be lit by a match</li> <li>- check that the wire is connected to the push button ignitor.</li> <li>- check if the push button ignitor needs tightening.</li> <li>- replace the wire if the wire insulation is broken or frayed.</li> <li>- replace the electrode if the ceramic insulator is cracked or broken.</li> <li>- replace the push button ignitor.</li> </ul>	
		Out of propane gas	<ul style="list-style-type: none"> <li>- fill the tank.</li> </ul>
		Spark gap is incorrect	<ul style="list-style-type: none"> <li>- spark gap should be 0.150" to 0.175" (5/32" to 11/64" approx.) from the electrode tip and the pilot burner. To ensure proper electrode location, tighten securing nut (finger tight plus 1/4 turn).</li> </ul>
		No gas at the pilot burner	<ul style="list-style-type: none"> <li>- check that the manual valve is turned on.</li> <li>- check the pilot orifice for blockage.</li> <li>- replace the valve.</li> <li>- call the gas distributor.</li> </ul>



SYMPTOM	PROBLEM	TEST SOLUTION
Pilot goes out while standing; Main burner is in 'OFF' position.	Gas piping is undersized.	<ul style="list-style-type: none"> <li>- turn on all gas appliances and see if pilot flame flutters, diminishes or extinguishes, especially when main burner ignites. Monitor appliance supply working pressure.</li> <li>- check if supply piping size is to code. Correct all undersized piping.</li> </ul>
Flames are consistently too large or too small. Carboning occurs.	Unit is over-fired or under-fired.	<ul style="list-style-type: none"> <li>- check pressure readings: Inlet pressure can be checked by turning screw (A) counter-clockwise 2 or 3 turns and then placing pressure gauge tubing over the test point. Gauge should read 7" (minimum 4.5") water column for natural gas or 13" (11" minimum) water column for propane. Check that main burner is operating on "HI".</li> <li>Outlet pressure can be checked the same as above using screw (B). Gauge should read 3.5" water column for natural gas or 10" water column for propane. Check that main burner is operating on "HI".</li> <li><b>AFTER TAKING PRESSURE READINGS, BE SURE TO TURN SCREWS CLOCKWISE FIRMLY TO RESEAL. DO NOT OVERTORQUE.</b> Leak test with a soap and water solution.</li> </ul>
Flames are very aggressive.	Door is ajar	- fit door assembly into the lower support brackets and secure the two door latches.
	Venting action is too great.	-restrict vent exit with restrictor plate, W500-0205.
Main burner flame is a blue, lazy, transparent flame.	Blockage in vent.	- remove blockage. In extremely cold conditions, ice buildup may occur on the terminal and should be removed as required.
	Incorrect installation.	- ensure correct location of storm collars.
Carbon is being deposited on glass, logs or combustion chamber surfaces.	Air shutter has become blocked	- ensure air shutter opening is free of lint or other obstructions.
	Flame is impinging on the logs or combustion chamber.	<ul style="list-style-type: none"> <li>- check that the logs are correctly positioned.</li> <li>- open air shutter to increase the primary air.</li> <li>- check the input rate: check the manifold pressure and orifice size as specified by the rating plate values.</li> <li>- check that the door gasketing is not broken or missing and that the seal is tight.</li> <li>- check that both 5" and 8" vent liners are free of holes and well sealed at all joints.</li> <li>- check that minimum rise per foot has been adhered to for any horizontal venting.</li> </ul>
White / grey film forms.	Sulphur from fuel is being deposited on glass, logs or combustion chamber surfaces.	<ul style="list-style-type: none"> <li>- clean the glass with a recommended gas fireplace glass cleaner. <b>DO NOT CLEAN GLASS WHEN HOT.</b></li> <li>If deposits are not cleaned off regularly, the glass may become permanently marked.</li> </ul>
Remote wall switch is in "OFF" position; main burner comes on when gas knob is turned to "ON" position.	Wall switch is mounted upside down	- reverse.
	Remote wall switch is grounding.	- replace.
	Remote wall switch wire is grounding.	- check for ground (short); repair ground or replace wire.
	Faulty valve.	- replace.

